



YAMAHA

2008

SERVICE MANUAL

**XV19SX(C)
XV19MX(C)
XV19CTSX(C)
XV19CTMX(C)
XV19CSX(C)
XV19CX(C)**



Star



Star

EAS20050

**XV19SX(C)/XV19MX(C)/XV19CTSX(C)/
XV19CTMX(C)/XV19CSX(C)/XV19CX(C)
SERVICE MANUAL**
©2007 by Yamaha Motor Corporation, U.S.A.
First edition, June 2007
All rights reserved.
**Any reproduction or unauthorized use
without the written permission of
Yamaha Motor Corporation, U.S.A.
is expressly prohibited.**
Printed in U.S.A.
P/N LIT-11616-21-26

NOTICE

This manual was produced by the Yamaha Motor Company, Ltd. primarily for use by Yamaha dealers and their qualified mechanics. It is not possible to include all the knowledge of a mechanic in one manual. Therefore, anyone who uses this book to perform maintenance and repairs on Yamaha vehicles should have a basic understanding of mechanics and the techniques to repair these types of vehicles. Repair and maintenance work attempted by anyone without this knowledge is likely to render the vehicle unsafe and unfit for use.

This model has been designed and manufactured to perform within certain specifications in regard to performance and emissions. Proper service with the correct tools is necessary to ensure that the vehicle will operate as designed. If there is any question about a service procedure, it is imperative that you contact a Yamaha dealer for any service information changes that apply to this model. This policy is intended to provide the customer with the most satisfaction from his vehicle and to conform to federal environmental quality objectives.

Yamaha Motor Company, Ltd. is continually striving to improve all of its models. Modifications and significant changes in specifications or procedures will be forwarded to all authorized Yamaha dealers and will appear in future editions of this manual where applicable.

NOTE:

- This Service Manual contains information regarding periodic maintenance to the emission control system. Please read this material carefully.
- Designs and specifications are subject to change without notice.

IMPORTANT MANUAL INFORMATION

Particularly important information is distinguished in this manual by the following.



The Safety Alert Symbol means ATTENTION! BECOME ALERT! YOUR SAFETY IS INVOLVED!



Failure to follow WARNING instructions could result in severe injury or death to the vehicle operator, a bystander or a person checking or repairing the vehicle.

CAUTION:

A CAUTION indicates special precautions that must be taken to avoid damage to the vehicle.

NOTE:

A NOTE provides key information to make procedures easier or clearer.

HOW TO USE THIS MANUAL

This manual is intended as a handy, easy-to-read reference book for the mechanic. Comprehensive explanations of all installation, removal, disassembly, assembly, repair and check procedures are laid out with the individual steps in sequential order.

- The manual is divided into chapters and each chapter is divided into sections. The current section title “1” is shown at the top of each page.
- Sub-section titles “2” appear in smaller print than the section title.
- To help identify parts and clarify procedure steps, there are exploded diagrams “3” at the start of each removal and disassembly section.
- Numbers “4” are given in the order of the jobs in the exploded diagram. A number indicates a disassembly step.
- Symbols “5” indicate parts to be lubricated or replaced. Refer to “SYMBOLS”.
- A job instruction chart “6” accompanies the exploded diagram, providing the order of jobs, names of parts, notes in jobs, etc.
- Jobs “7” requiring more information (such as special tools and technical data) are described sequentially.

1
↓
CLUTCH

CLUTCH
Removing the clutch cover

3

4

5

6

Order	Job/Parts to remove	Q'ty	Remarks
	Engine oil		Drain. Refer to "CHANGING THE ENGINE OIL" on page 5-11.
	Left side cover		Refer to "GENERAL CHASSIS" on page 4-1.
	Horn 1/Canister		Refer to "THROTTLE BODIES" on page 6-7. For California only.
	Fuel tank/Sub-fuel tank		Refer to "FUEL TANK" on page 6-1.
	Left rider footrest assembly/Shift rod/Sidestand		Refer to "ENGINE REMOVAL" on page 5-1.
	Generator cover		Refer to "GENERATOR AND STARTER CLUTCH" on page 5-77.
	Drive pulley case		Refer to "TRANSFER GEAR CASE" on page 5-86.
1	Crankshaft position sensor coupler	1	Disconnect.
2	Shift arm	1	
3	Protector	1	For XV19CS(C)/ XV19C(C)
4	Fuel tank breather/overflow hose pipe bracket	1	For XV19CS(C)/ XV19C(C)
5	Fuel tank breather/overflow hose holder bracket	1	For US only. For XV19CS(C)/ XV19C(C)

5-53

CLUTCH

REMOVING THE CLUTCH

1. Loosen:
• Clutch boss nut "1"

NOTE:
While holding the clutch boss "2" with the universal clutch holder "3", loosen the clutch boss nut.

Universal clutch holder
90890-04086
YM-91042

2. Remove:
• Clutch boss nut "1"
• Conical spring washer "2"
• Washer "3"
• Clutch boss assembly "4"

NOTE:
There is a built-in damper between the clutch boss and the clutch plate. It is not necessary to remove the wire circlip "5" and disassemble the built-in damper unless there is serious clutch chattering.

CAUTION
REMOVING THE PRIMARY DRIVE GEAR

1. Loosen:
• Primary drive gear bolt "1"

NOTE:
While holding the generator rotor "2" with the sheave holder "3", loosen the primary drive gear bolt.

Sheave holder
90890-01701
Primary clutch holder
YS-01680-A

Sheave holder
90890-01701
Primary clutch holder
YS-01680-A

7

2

5-64

SYMBOLS

The following symbols are used in this manual for easier understanding.

NOTE: _____

The following symbols are not relevant to every vehicle.

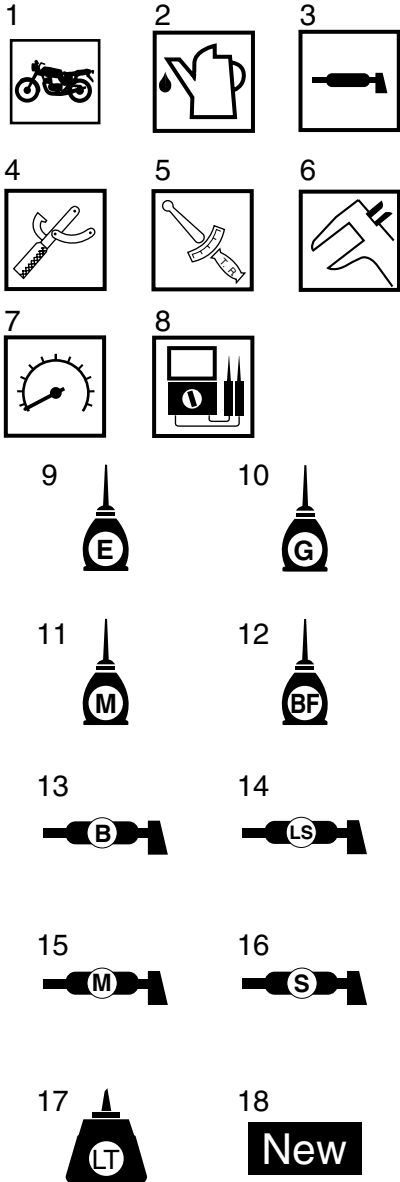

1. Serviceable with engine mounted
2. Filling fluid
3. Lubricant
4. Special tool
5. Tightening torque
6. Wear limit, clearance
7. Engine speed
8. Electrical data
9. Engine oil
10. Gear oil
11. Molybdenum-disulfide oil
12. Brake fluid
13. Wheel-bearing grease
14. Lithium-soap-based grease
15. Molybdenum-disulfide grease
16. Silicone grease
17. Apply locking agent (LOCTITE®).
18. Replace the part with a new one.



TABLE OF CONTENTS

GENERAL INFORMATION	1
SPECIFICATIONS	2
PERIODIC CHECKS AND ADJUSTMENTS	3
CHASSIS	4
ENGINE	5
FUEL SYSTEM	6
ELECTRICAL SYSTEM	7
TROUBLESHOOTING	8



GENERAL INFORMATION

IDENTIFICATION	1-1
VEHICLE IDENTIFICATION NUMBER	1-1
MODEL LABEL.....	1-1
FEATURES	1-2
OUTLINE OF THE FI SYSTEM.....	1-2
FI SYSTEM.....	1-3
INSTRUMENT FUNCTIONS (for XV19S(C)/ XV19M(C)/ XV19CTS(C)/ XV19CTM(C)).....	1-4
INSTRUMENT FUNCTIONS (for XV19CS(C)/ XV19C(C))	1-7
IMPORTANT INFORMATION	1-11
PREPARATION FOR REMOVAL AND DISASSEMBLY	1-11
REPLACEMENT PARTS.....	1-11
GASKETS, OIL SEALS AND O-RINGS	1-11
LOCK WASHERS/PLATES AND COTTER PINS	1-11
BEARINGS AND OIL SEALS	1-12
CIRCLIPS	1-12
CHECKING THE CONNECTIONS	1-13
SPECIAL TOOLS	1-14

EAS20130

IDENTIFICATION

EAS20140

VEHICLE IDENTIFICATION NUMBER

The vehicle identification number "1" is stamped into the right side of the steering head pipe.

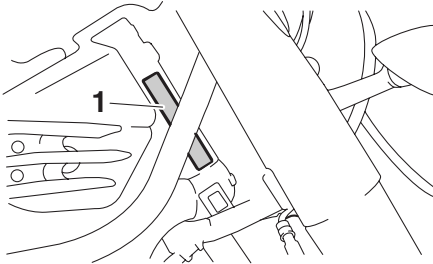

EAS20150

MODEL LABEL

The model label "1" is affixed to the frame under the rider seat. This information will be needed to order spare parts.

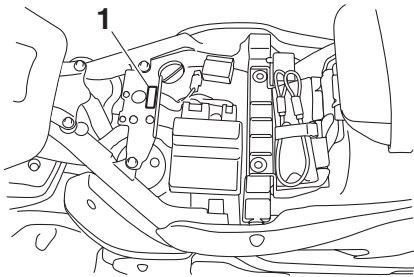

EAS20170

FEATURES

ET1D71017

OUTLINE OF THE FI SYSTEM

The main function of a fuel supply system is to provide fuel to the combustion chamber at the optimum air-fuel ratio in accordance with the engine operating conditions and the atmospheric temperature. In the conventional carburetor system, the air-fuel ratio of the mixture that is supplied to the combustion chamber is created by the volume of the intake air and the fuel that is metered by the jet used in the respective carburetor.

Despite the same volume of intake air, the fuel volume requirement varies by the engine operating conditions, such as acceleration, deceleration, or operating under a heavy load. Carburetors that meter the fuel through the use of jets have been provided with various auxiliary devices, so that an optimum air-fuel ratio can be achieved to accommodate the constant changes in the operating conditions of the engine.

As the requirements for the engine to deliver more performance and cleaner exhaust gases increase, it becomes necessary to control the air-fuel ratio in a more precise and finely tuned manner. To accommodate this need, this model has adopted an electronically controlled fuel injection (FI) system, in place of the conventional carburetor system. This system can achieve an optimum air-fuel ratio required by the engine at all times by using a microprocessor that regulates the fuel injection volume according to the engine operating conditions detected by various sensors.

The adoption of the FI system has resulted in a highly precise fuel supply, improved engine response, better fuel economy, and reduced exhaust emissions.

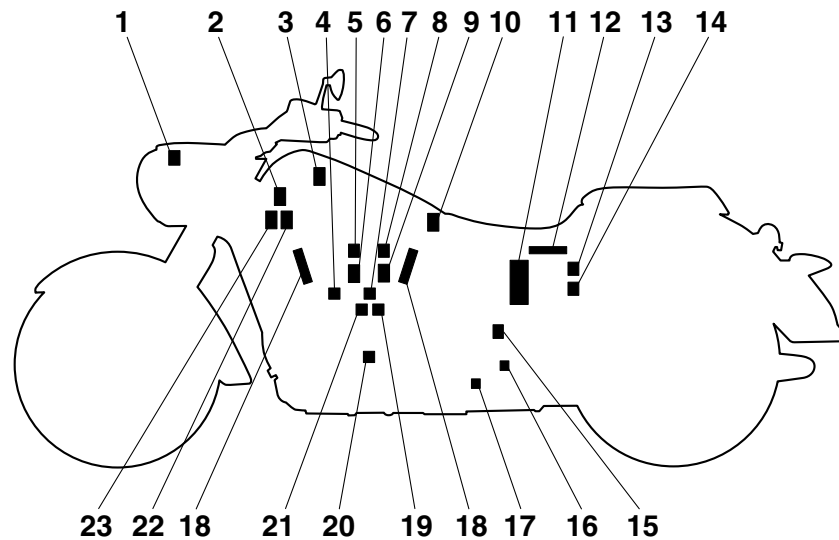

- | | |
|---|--|
| 1. Air temperature sensor | 12. ECU (electronic control unit) |
| 2. ISC (idle speed control) unit | 13. Relay unit (fuel pump relay) |
| 3. Cylinder-#2 intake air pressure sensor | 14. EXUP servo motor |
| 4. Engine temperature sensor | 15. Speed sensor |
| 5. Cylinder-#2 left and right ignition coils (for XV19CS(C)/ XV19C(C)) | 16. O ₂ sensor |
| 6. Cylinder-#1 right ignition coil (for XV19S(C)/ XV19M(C)/ XV19CTS(C)/ XV19CTM(C)) | 17. Lean angle sensor |
| 7. Throttle position sensor | 18. Spark plug |
| 8. Cylinder-#1 left and right ignition coils (for XV19CS(C)/ XV19C(C)) | 19. Injector #1 |
| 9. Cylinder-#1 left ignition coil (for XV19S(C)/ XV19M(C)/ XV19CTS(C)/ XV19CTM(C)) | 20. Crankshaft position sensor |
| 10. Cylinder-#1 intake air pressure sensor | 21. Injector #2 |
| 11. Fuel pump | 22. Cylinder-#2 right ignition coil (for XV19S(C)/ XV19M(C)/ XV19CTS(C)/ XV19CTM(C)) |
| | 23. Cylinder-#2 left ignition coil (for XV19S(C)/ XV19M(C)/ XV19CTS(C)/ XV19CTM(C)) |

ET1D71018

FI SYSTEM

The fuel pump delivers fuel to the fuel injector via the fuel filter. The pressure regulator maintains the fuel pressure that is applied to the fuel injector at only 392 kPa (3.92 kg/cm², 55.7 psi). Accordingly, when the energizing signal from the ECU energizes the fuel injector, the fuel passage opens, causing the fuel to be injected into the intake manifold only during the time the passage remains open. Therefore, the longer the length of time the fuel injector is energized (injection duration), the greater the volume of fuel that is supplied. Conversely, the shorter the length of time the fuel injector is energized (injection duration), the lesser the volume of fuel that is supplied.

The injection duration and the injection timing are controlled by the ECU. Signals that are input from the throttle position sensor, crankshaft position sensor, intake air pressure sensor, air temperature sensor, engine temperature sensor, speed sensor and O₂ sensor enable the ECU to determine the injection duration. The injection timing is determined through the signals from the crankshaft position sensor. As a result, the volume of fuel that is required by the engine can be supplied at all times in accordance with the driving conditions.

Illustration is for reference only.

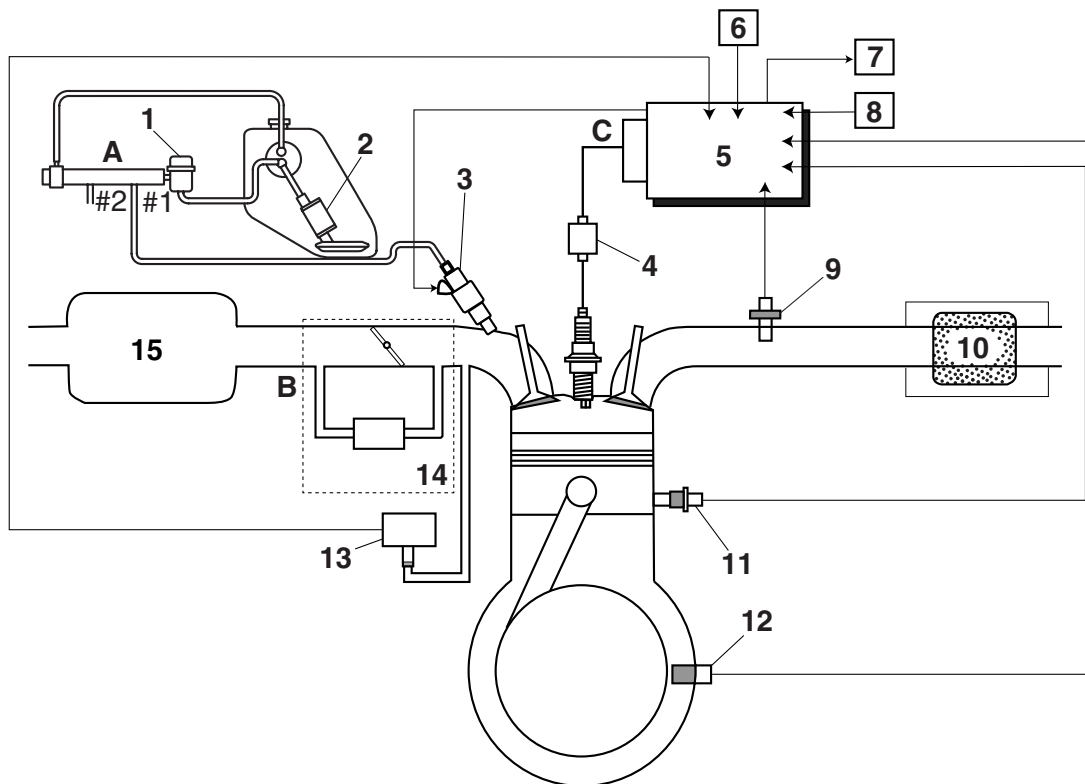

- | | |
|----------------------------------|--------------------------------|
| 1. Pressure regulator | 13. Intake air pressure sensor |
| 2. Fuel pump | 14. Throttle body |
| 3. Fuel injector | 15. Air filter case |
| 4. Ignition coil | |
| 5. ECU (electronic control unit) | A. Fuel system |
| 6. Air temperature sensor | B. Air system |
| 7. ISC (idle speed control) unit | C. Control system |
| 8. Throttle position sensor | |
| 9. O ₂ sensor | |
| 10. Catalytic converter | |
| 11. Engine temperature sensor | |
| 12. Crankshaft position sensor | |

ET1D71036

INSTRUMENT FUNCTIONS (for XV19S(C)/ XV19M(C)/ XV19CTS(C)/ XV19CTM(C))

Multi-function meter unit

EW1D71008

WARNING

Be sure to stop the vehicle before making any setting changes to the multi-function meter unit.

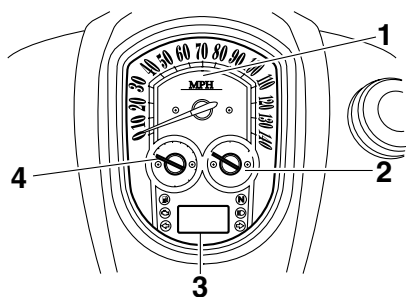

1. Speedometer
2. Fuel gauge
3. Odometer/tripmeter/fuel reserve tripmeter/clock
4. Tachometer

The multi-function meter unit is equipped with the following:

- a speedometer (which shows the riding speed)
- a tachometer (which shows the engine speed)
- a fuel gauge
- an odometer (which shows the total distance traveled)
- two tripmeters (which show the distance traveled since they were last set to zero)
- a fuel reserve tripmeter (which shows the distance traveled on the fuel reserve)
- a clock
- a self-diagnosis device
- a brightness control mode

NOTE:

- Be sure to turn the key to "ON" before using the "SELECT" and "RESET" switches, except for setting the brightness control mode.
- To switch the odometer, the tripmeters and the fuel reserve tripmeter displays between kilometers and miles, press the "SELECT" switch for at least two seconds. (for USA and California only)

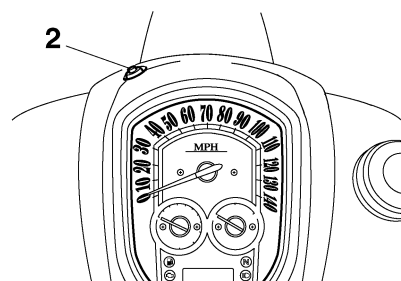
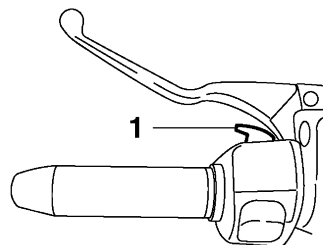

1. "SELECT" switch
2. "RESET" switch

Speedometer

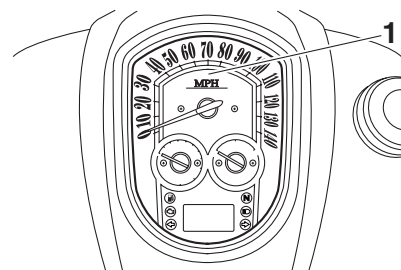

1. Speedometer

The speedometer shows the riding speed. When the key is turned to "ON", the speedometer needle will sweep once across the speed range and then return to zero in order to test the electrical circuit.

Tachometer

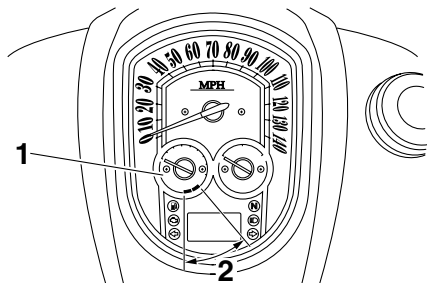

1. Tachometer
2. Tachometer red zone

The electric tachometer allows the rider to monitor the engine speed and keep it within the ideal power range.

When the key is turned to “ON”, the tachometer needle will sweep once across the r/min range and then return to zero r/min in order to test the electrical circuit.

EC1D71017

CAUTION:

Do not operate the engine in the tachometer red zone.

Red zone: 5000 r/min and above

Fuel gauge

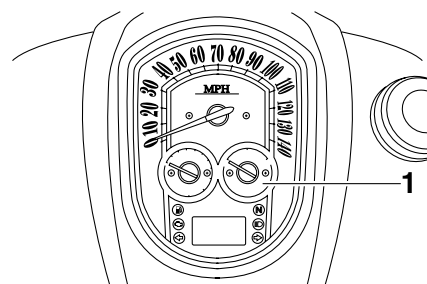

1. Fuel gauge

The fuel gauge indicates the amount of fuel in the fuel tank. The needle moves towards “E” (Empty) as the fuel level decreases. When the needle reaches “E”, approximately 3.0 L (0.79 US gal) (0.66 Imp.gal) remain in the fuel tank. If this occurs, refuel as soon as possible.

When the key is turned to “ON”, the fuel gauge needle will sweep once across the fuel level range and then return to the current amount in order to test the electrical circuit.

NOTE:

- Do not allow the fuel tank to empty itself completely.

- The fuel gauge does not indicate the correct fuel level for the first 5 km/h (3 mi/h) after refueling.

Odometer, tripmeter, and clock modes

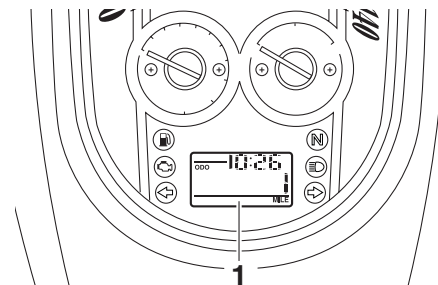

1. Odometer/tripmeter/fuel reserve tripmeter/clock

Push the “SELECT” switch to switch the display between the odometer mode “ODO”, the tripmeter modes “TRIP 1” and “TRIP 2” and the clock mode in the following order:

ODO → TRIP 1 → TRIP 2 → Clock → ODO

If the fuel level warning light comes on, the odometer display will automatically change to the fuel reserve tripmeter mode “F-TRIP” and start counting the distance traveled from that point. In that case, push the “SELECT” switch to switch the display between the various tripmeter, odometer, and clock modes in the following order:

F-TRIP → TRIP 1 → TRIP 2 → Clock → ODO → F-TRIP

To reset a tripmeter, select it by pushing the “SELECT” switch, and then push the “RESET” switch for at least one second. If you do not reset the fuel reserve tripmeter manually, it will reset itself automatically, and the display will return to the prior mode after refueling and traveling 5 km (3 mi).

Clock mode

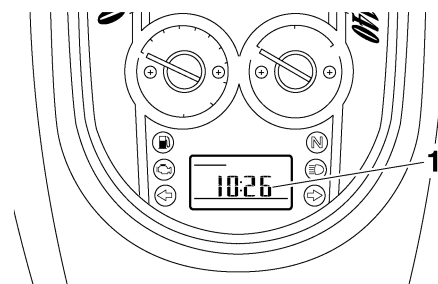

1. Clock

To set the clock:

1. Push the "SELECT" switch to change the display to the clock mode.
2. Push the "SELECT" and "RESET" switches together for at least two seconds.
3. When the hour digits start flashing, push the "RESET" switch to set the hours.
4. Push the "SELECT" switch, and the minute digits will start flashing.
5. Push the "RESET" switch to set the minutes.
6. Push the "SELECT" switch and then release it to start the clock.

Self-diagnosis device

This model is equipped with a self-diagnosis device for various electrical circuits.

If any of those circuits are defective, the engine trouble warning light will come on, and then the odometer/tripmeter/clock display will indicate a two-digit error code (e.g., 12, 13, 14).

If the odometer/tripmeter/clock display indicates any error codes, note the code number, and then check the vehicle. Refer to "FUEL INJECTION SYSTEM" on page 7-27.

EC1D71018

CAUTION:

If the display indicates an error code, the vehicle should be checked as soon as possible in order to avoid engine damage.

Brightness control mode

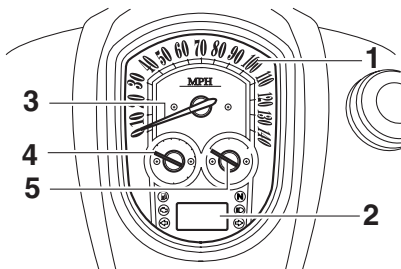

1. Multi-function meter unit panel
2. LCD
3. Speedometer needle
4. Tachometer needle
5. Fuel gauge needle

The brightness can be adjusted for the following:

- the multi-function meter unit panel (item number "1")
- the LCD (item number "2")
- the speedometer, tachometer, and the fuel gauge needles (item number "3")

Select the brightness control mode as follows.

1. Turn the key to "OFF".
2. Push and hold the "SELECT" switch.
3. Turn the key to "ON", and then release the "SELECT" switch after five seconds. Item number "1" is displayed.

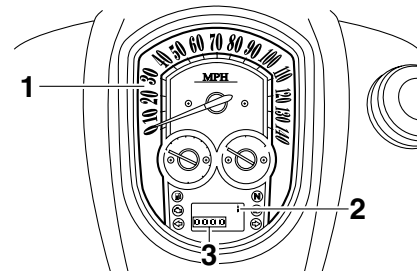

1. Multi-function meter unit panel
2. Item number
3. Brightness level
4. Adjust the multi-function meter unit panel brightness level by pushing the "RESET" switch.
5. Push the "SELECT" switch to select the LCD. Item number "2" is displayed. Adjust the LCD brightness level by pushing the "RESET" switch.

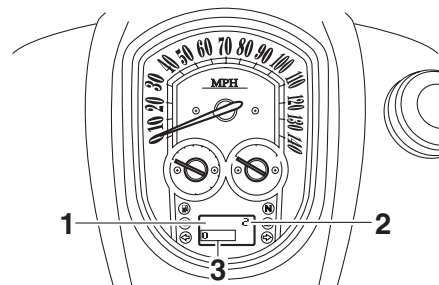

1. LCD
2. Item number
3. Brightness level
6. Push the "SELECT" switch to select the speedometer, tachometer, and the fuel gauge needles. Item number "3" is displayed. Adjust the brightness level of the speedometer, tachometer, and the fuel gauge needles by pushing the "RESET" switch.

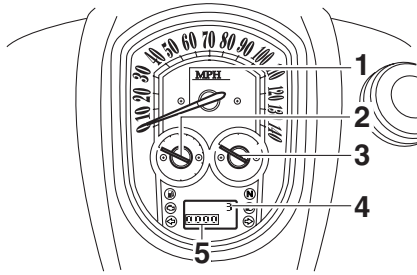

1. Speedometer needle
2. Tachometer needle
3. Fuel gauge needle
4. Item number
5. Brightness level

7. Push the “SELECT” switch.
The odometer/tripmeter/clock display will return to the prior mode.

EAS1D77010

INSTRUMENT FUNCTIONS (for XV19CS(C)/XV19C(C))

Multi-function meter unit

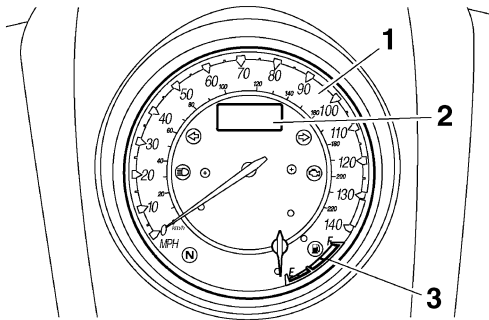

1. Speedometer
2. Odometer/tripmeter/fuel reserve tripmeter/clock
3. Fuel gauge

EWA1D77001

WARNING

Be sure to stop the vehicle before making any setting changes to the multi-function meter unit.

The multi-function meter unit is equipped with the following:

- a speedometer (which shows the riding speed)
- a fuel gauge
- an odometer (which shows the total distance traveled)
- two tripmeters (which show the distance traveled since they were last set to zero)

- a fuel reserve tripmeter (which shows the distance traveled on the fuel reserve)
- a clock
- a self-diagnosis device
- a brightness control mode

NOTE:

Be sure to turn the key to “ON” before using the “SELECT” and reset switches, except for setting the brightness control mode.

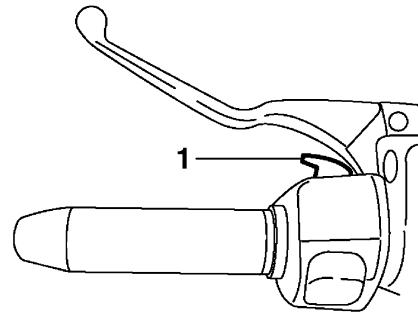

1. “SELECT” switch

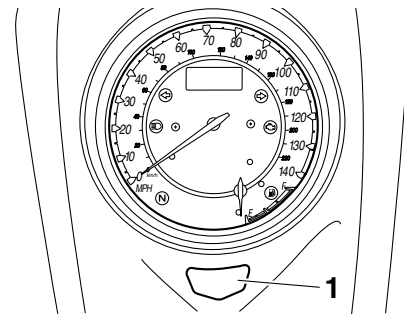

1. Reset switch

Speedometer

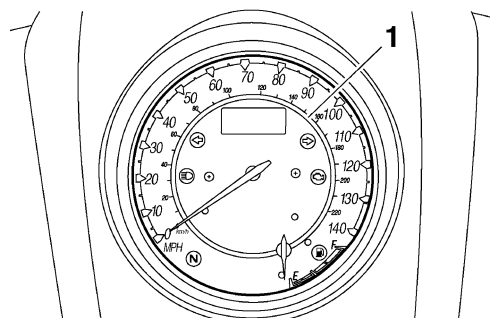

1. Speedometer

When the key is turned to “ON”, the speedometer needle will sweep once across the speed range and then return to zero in order to test the electrical circuit.

Fuel gauge

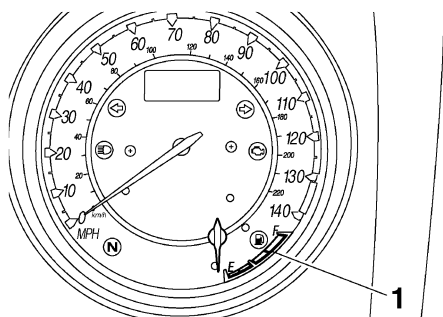

1. Fuel gauge

The fuel gauge indicates the amount of fuel in the fuel tank. The needle moves towards “E” (Empty) as the fuel level decreases. When the needle reaches “E”, approximately 3.0 L (0.79 US gal) (0.66 Imp.gal) remain in the fuel tank. If this occurs, refuel as soon as possible.

When the key is turned to “ON”, the fuel gauge needle will sweep once across the fuel level range and then return to the current amount in order to test the electrical circuit.

NOTE:

- Do not allow the fuel tank to empty itself completely.
- The fuel gauge does not indicate the correct fuel level for the first 5 km/h (3 mi/h) after refueling.

Operation of the fuel gauge and fuel level warning light

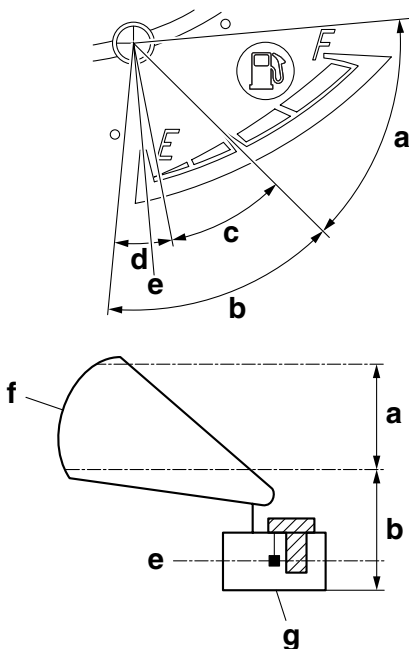

a. Fuel sender detection range

- b. Estimation range
- c. Main fuel tank estimation range
- d. Sub-fuel tank estimation range
- e. Fuel level warning light activation point
- f. Main fuel tank
- g. Sub-fuel tank

These models are equipped with two fuel tanks: the main fuel tank and the sub-fuel tank. Since the fuel sender, which is used to detect the fuel level, is installed in the main fuel tank, it is not able to detect the fuel level throughout the entire range, which includes the sub-fuel tank. (The fuel sender detection range is from the full level [approximately 16 L (4.23 US gal) (3.52 Imp.gal)] to the half-full level [approximately 8 L (2.11 US gal) (1.72 Imp.gal)].)

For the fuel level range that the fuel sender is not able to detect, the fuel level is calculated using the distance traveled and preset fuel consumption values according to vehicle speed. (The estimation range is from 0 L to the half-full level [approximately 8 L (2.11 US gal) (1.72 Imp.gal)].)

The fuel gauge operates according to the fuel sender in the detection range “a” and according to the estimation in the range “b”.

When the fuel level reaches the fuel level warning light activation point “e”, the warning light is activated by the fuel pump thermistor in the sub-fuel tank.

Operation of the fuel gauge and fuel level warning light after refueling

If the fuel level remains in the estimation range “b” after refueling, the fuel gauge will not operate. However, if the fuel level reaches the fuel sender detection range “a”, the fuel gauge will operate and the fuel level will be displayed.

The fuel level warning light will go off when the fuel level is above the activation point “e”, even if the fuel level remains in the estimation range.

Odometer, tripmeters, fuel reserve tripmeter and clock

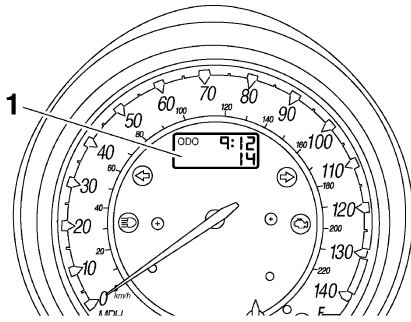

1. Odometer/tripmeter/fuel reserve tripmeter/clock

Push the “SELECT” switch to change the display between the odometer mode “ODO”, the tripmeter modes “TRIP A” and “TRIP B” in the following order:

ODO → TRIP A → TRIP B → ODO

If the fuel level warning light comes on, the odometer display will automatically change to the fuel reserve tripmeter mode “F-TRIP” and start counting the distance traveled from that point. In that case, push the “SELECT” switch to change the display between the various tripmeter and odometer modes in the following order: F-TRIP → TRIP A → TRIP B → ODO → F-TRIP

To reset a tripmeter, select it by pushing the “SELECT” switch, and then push the reset switch for at least one second. If you do not reset the fuel reserve tripmeter manually, it will reset itself automatically, and the display will return to the prior mode after refueling and traveling 5 km (3 mi).

To set the clock

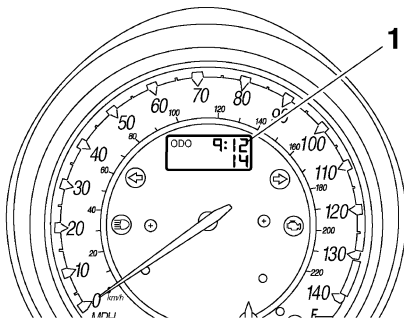

1. Clock

1. Push the “SELECT” and reset switches together for at least three seconds.
2. When the hour digits start flashing, push the reset switch to set the hours.
3. Push the “SELECT” switch, and the minute digits will start flashing.
4. Push the reset switch to set the minutes.
5. Push the “SELECT” switch and then release it to start the clock.

Self-diagnosis devices

This model is equipped with a self-diagnosis device for various electrical circuits.

If any of those circuits are defective, the engine trouble warning light will come on, and then the odometer/tripmeter/clock display will indicate a two-digit error code.

If the odometer/tripmeter/clock display indicates any error codes, note the code number, and then have a Yamaha dealer check the vehicle.

ECA1D77001

CAUTION:

If the display indicates an error code, the vehicle should be checked as soon as possible in order to avoid engine damage.

Brightness control mode

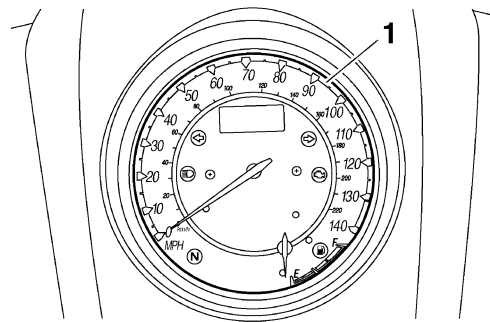

1. Multi-function meter unit panel

This function allows you to adjust the brightness of the multi-function meter unit panel to suit the outside lighting conditions.

To set the brightness

1. Turn the key to “OFF”.
2. Push and hold the “SELECT” switch.
3. Turn the key to “ON”, and then release the “SELECT” switch after five seconds.

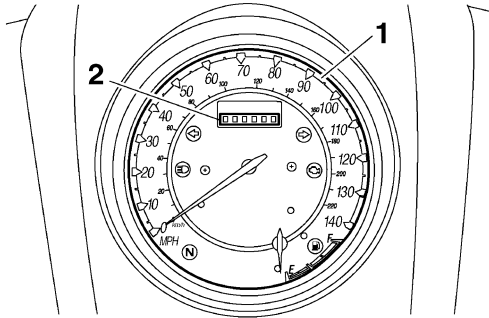

1. Multi-function meter unit panel
2. Brightness level
4. Adjust the multi-function meter unit panel brightness level by pushing the reset switch.
5. Push the “SELECT” switch.
The odometer/tripmeter/clock display will return to the prior mode.

EAS20180

IMPORTANT INFORMATION

EAS20190

PREPARATION FOR REMOVAL AND DISASSEMBLY

1. Before removal and disassembly, remove all dirt, mud, dust and foreign material.

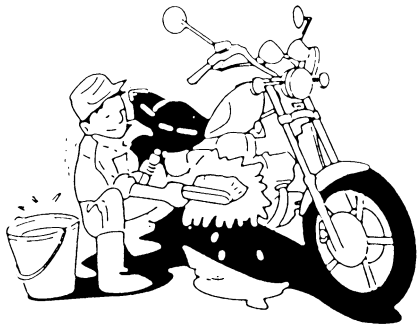

2. Use only the proper tools and cleaning equipment.

Refer to "SPECIAL TOOLS" on page 1-14.

3. When disassembling, always keep mated parts together. This includes gears, cylinders, pistons and other parts that have been "mated" through normal wear. Mated parts must always be reused or replaced as an assembly.

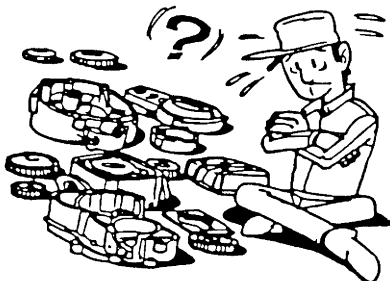

4. During disassembly, clean all of the parts and place them in trays in the order of disassembly. This will speed up assembly and allow for the correct installation of all parts.
5. Keep all parts away from any source of fire.

EAS20200

REPLACEMENT PARTS

Use only genuine Yamaha parts for all replacements. Use oil and grease recommended by Yamaha for all lubrication jobs. Other brands may be similar in function and appearance, but inferior in quality.

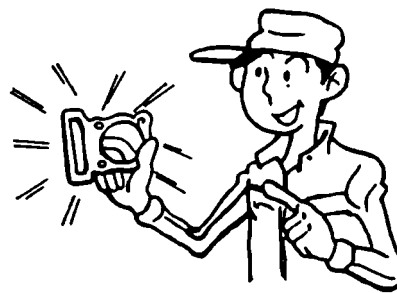

EAS20210

GASKETS, OIL SEALS AND O-RINGS

1. When overhauling the engine, replace all gaskets, seals and O-rings. All gasket surfaces, oil seal lips and O-rings must be cleaned.
2. During reassembly, properly oil all mating parts and bearings and lubricate the oil seal lips with grease.

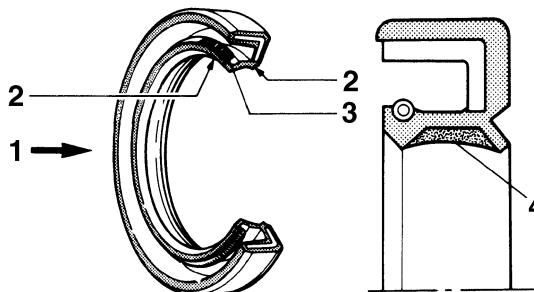

1. Oil
2. Lip
3. Spring
4. Grease

EAS20220

LOCK WASHERS/PLATES AND COTTER PINS

After removal, replace all lock washers/plates "1" and cotter pins. After the bolt or nut has been tightened to specification, bend the lock tabs along a flat of the bolt or nut.

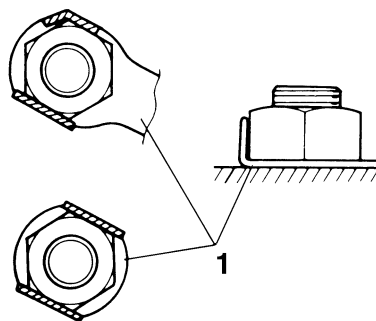

EAS20230

BEARINGS AND OIL SEALS

Install bearings and oil seals so that the manufacturer's marks or numbers are visible. When installing oil seals "1", lubricate the oil seal lips with a light coat of lithium-soap-based grease. Oil bearings liberally when installing, if appropriate.

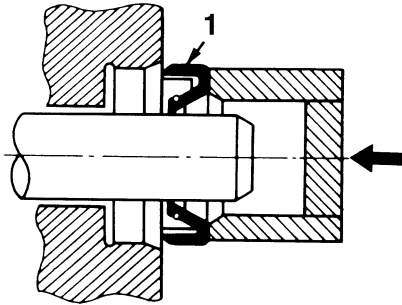

ECA13300

CAUTION:

Do not spin the bearing with compressed air because this will damage the bearing surfaces.

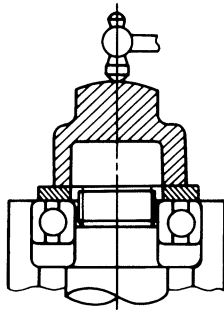

EAS20240

CIRCLIPS

Before reassembly, check all circlips carefully and replace damaged or distorted circlips. Always replace piston pin clips after one use. When installing a circlip "1", make sure the sharp-edged corner "2" is positioned opposite the thrust "3" that the circlip receives.

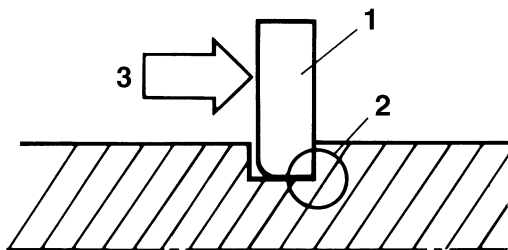

CHECKING THE CONNECTIONS

EAS20250

CHECKING THE CONNECTIONS

Check the leads, couplers, and connectors for stains, rust, moisture, etc.

1. Disconnect:

- Lead
- Coupler
- Connector

2. Check:

- Lead
- Coupler
- Connector

Moisture → Dry with an air blower.

Rust/stains → Connect and disconnect several times.

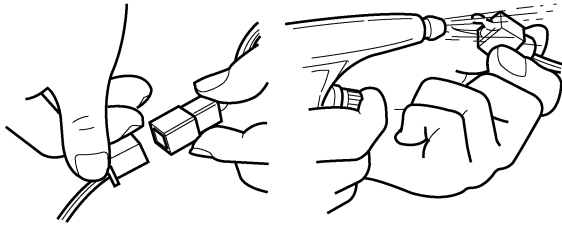

3. Check:

- All connections

Loose connection → Connect properly.

NOTE:

If the pin "1" on the terminal is flattened, bend it up.

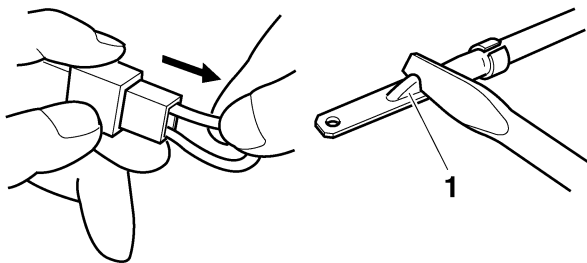

4. Connect:

- Lead
- Coupler
- Connector

NOTE:

Make sure all connections are tight.

5. Check:

- Continuity
(with the pocket tester)



Pocket tester
90890-03112
Analog pocket tester
YU-03112-C

NOTE:

- If there is no continuity, clean the terminals.
- When checking the wire harness, perform steps (1) to (3).
- As a quick remedy, use a contact revitalizer available at most part stores.

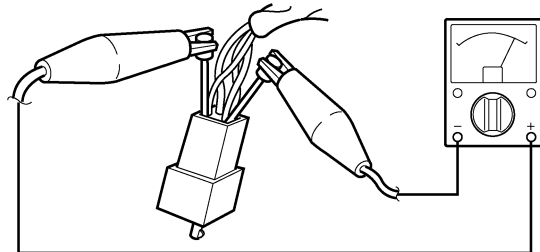
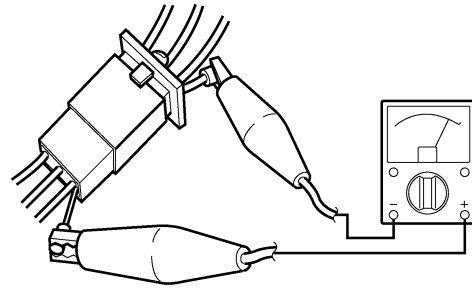



EAS20260

SPECIAL TOOLS

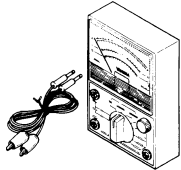
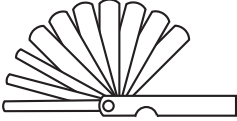
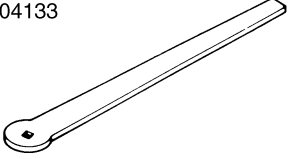
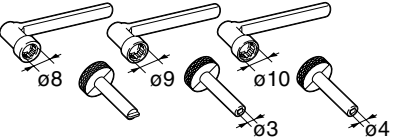
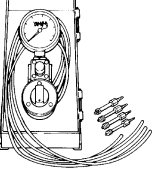

The following special tools are necessary for complete and accurate tune-up and assembly. Use only the appropriate special tools as this will help prevent damage caused by the use of inappropriate tools or improvised techniques. Special tools, part numbers or both may differ depending on the country. When placing an order, refer to the list provided below to avoid any mistakes.

NOTE:

- For U.S.A. and Canada, use part number starting with “YM-”, “YU-”, or “ACC-”.
- For others, use part number starting with “90890-”.

Tool name/Tool No.	Illustration	Reference pages
Pocket tester 90890-03112 Analog pocket tester YU-03112-C		1-13, 5-84, 7-73, 7-74, 7-75, 7-79, 7-80, 7-81, 7-82, 7-83, 7-84, 7-85, 7-86, 7-87, 7-88, 7-89, 7-91
Thickness gauge 90890-03180 Feeler gauge set YU-26900-9		3-6, 5-65
Tappet adjusting tool (4 mm) 90890-04133 Six piece tappet set YM-A5970	90890-04133  YM-A5970 	3-6, 3-7
Vacuum gauge 90890-03094 Carburetor synchronizer YU-44456	90890-03094  YU-44456 	3-7

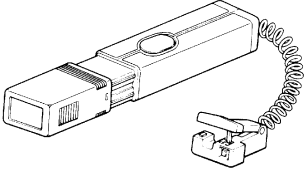
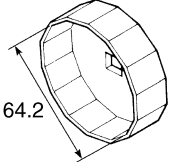
SPECIAL TOOLS

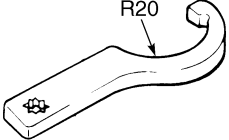
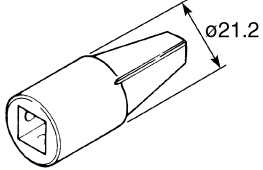
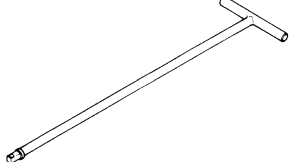
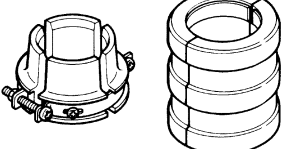
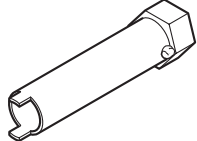
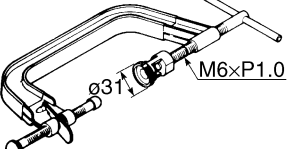
Tool name/Tool No.	Illustration	Reference pages
Timing light 90890-03141 Inductive clamp timing light YU-03141		3-10
Oil filter wrench 90890-01426 YU-38411		3-12
Belt tension gauge 90890-03170 Rear drive belt tension gauge YM-03170		3-26
Steering nut wrench 90890-01403 Spanner wrench YU-33975		3-27, 4-81
Damper rod holder 90890-01460		4-71, 4-73
T-handle 90890-01326 T-handle 3/8" drive 60 cm long YM-01326		4-71, 4-73
Fork seal driver 90890-01442 Adjustable fork seal driver (36–46 mm) YM-01442		4-73, 4-74
Pivot shaft wrench 90890-01485 Frame mount insert wrench YM-01485		5-15
Valve spring compressor 90890-04019 YM-04019		5-42, 5-47

SPECIAL TOOLS

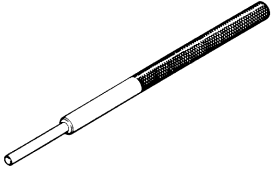
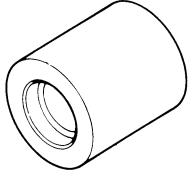
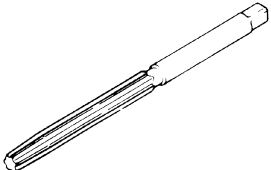
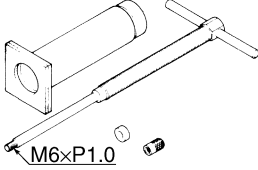
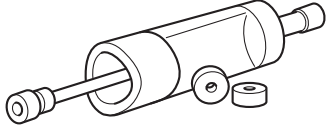
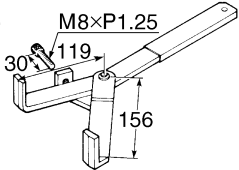
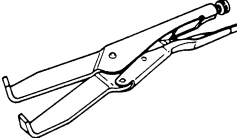
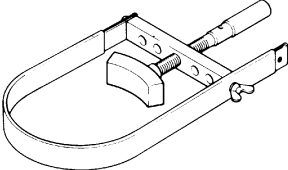
Tool name/Tool No.	Illustration	Reference pages
Valve guide remover (ø6) 90890-04064 Valve guide remover (6.0 mm) YM-04064-A		5-43
Valve guide installer (ø6) 90890-04065 Valve guide installer (6.0 mm) YM-04065-A		5-43
Valve guide reamer (ø6) 90890-04066 Valve guide reamer (6.0 mm) YM-04066		5-43
Piston pin puller set 90890-01304 Piston pin puller YU-01304	90890-01304  M6xP1.0 YU-01304 	5-49
Universal clutch holder 90890-04086 YM-91042	90890-04086  M8xP1.25 30° 119 156 YM-91042 	5-64, 5-69
Sheave holder 90890-01701 Primary clutch holder YS-01880-A		5-64, 5-68, 5-79, 5-80

SPECIAL TOOLS

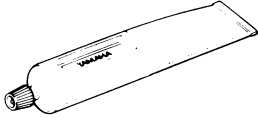
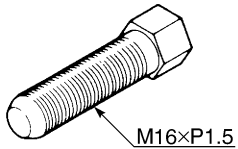
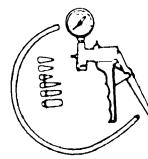
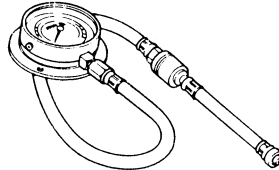
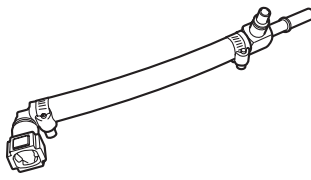
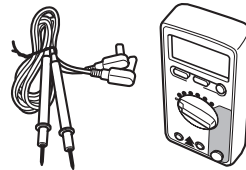
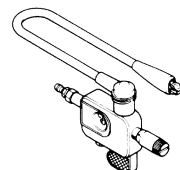
Tool name/Tool No.	Illustration	Reference pages
Yamaha bond No. 1215 90890-85505 (Three Bond No.1215®)		5-70, 5-80, 5-98
Rotor puller 90890-01080 Stator rotor puller YM-01080-A		5-79
Vacuum/pressure pump gauge set 90890-06756 Mityvac brake bleeding tool YS-42423		6-16
Pressure gauge 90890-03153 YU-03153		6-16
Fuel pressure adapter 90890-03176 YM-03176		6-16
Digital circuit tester 90890-03174 Model 88 Multimeter with tachometer YU-A1927		6-16
Ignition checker 90890-06754 Opama pet-4000 spark checker YM-34487		7-83

SPECIFICATIONS

GENERAL SPECIFICATIONS	2-1
ENGINE SPECIFICATIONS	2-3
CHASSIS SPECIFICATIONS	2-11
ELECTRICAL SPECIFICATIONS	2-16
TIGHTENING TORQUES	2-20
GENERAL TIGHTENING TORQUE SPECIFICATIONS	2-20
ENGINE TIGHTENING TORQUES	2-21
CHASSIS TIGHTENING TORQUES	2-26
LUBRICATION POINTS AND LUBRICANT TYPES	2-33
ENGINE	2-33
CHASSIS	2-35
LUBRICATION SYSTEM CHART AND DIAGRAMS	2-37
ENGINE OIL LUBRICATION CHART	2-37
LUBRICATION DIAGRAMS	2-39
CABLE ROUTING (for XV19S(C)/ XV19M(C)/ XV19CTS(C)/ XV19CTM(C))	2-51
CABLE ROUTING (for XV19CS(C)/ XV19C(C))	2-67

GENERAL SPECIFICATIONS

EAS20280

GENERAL SPECIFICATIONS

Model

Model

XV19SX 1D77 (USA)
XV19SXC 1D78 (California)
XV19SX 1D79 (CDN)
XV19MX 4D57 (USA)
XV19MXC 4D58 (California)
XV19MX 4D59 (CDN)
XV19CTSX 2C57 (USA)
XV19CTSXC 2C58 (California)
XV19CTSX 2C59 (CDN)
XV19CTMX 4P17 (USA)
XV19CTMXC 4P18 (California)
XV19CTMX 4P19 (CDN)
XV19CSX 29P1/5C71 (USA)
XV19CSXC 29P2/5C72 (California)
XV19CSX 29P3/5C73 (CDN)
XV19CX 29S1/30B1 (USA)
XV19CXC 29S2/30B2 (California)
XV19CX 29S3/30B3 (CDN)

Dimensions

Overall length

XV19S(C)/ XV19M(C)/ XV19CTS(C)/
XV19CTM(C):
2580 mm (101.6 in)
XV19CS(C)/ XV19C(C):

Overall width

2572 mm (101.3 in)
XV19S(C)/ XV19M(C)/ XV19CTS(C)/
XV19CTM(C):
1100 mm (43.3 in)
XV19CS(C)/ XV19C(C):

Overall height

925 mm (36.4 in)
XV19S(C)/ XV19M(C):
1100 mm (43.3 in)
XV19CTS(C)/ XV19CTM(C):
1515 mm (59.6 in)
XV19CS(C)/ XV19C(C):

Seat height

1165 mm (45.9 in)
XV19S(C)/ XV19M(C)/ XV19CTS(C)/
XV19CTM(C):
735 mm (28.9 in)
XV19CS(C)/ XV19C(C):

Wheelbase

695 mm (27.4 in)
XV19S(C)/ XV19M(C)/ XV19CTS(C)/
XV19CTM(C):
1715 mm (67.5 in)
XV19CS(C)/ XV19C(C):
1799 mm (70.8 in)

GENERAL SPECIFICATIONS

Ground clearance	XV19S(C)/ XV19M(C)/ XV19CTS(C)/ XV19CTM(C): 155 mm (6.10 in) XV19CS(C)/ XV19C(C): 146 mm (5.75 in)
Minimum turning radius	XV19S(C)/ XV19M(C)/ XV19CTS(C)/ XV19CTM(C): 3480 mm (137.0 in) XV19CS(C)/ XV19C(C): 3500 mm (137.8 in)

Weight

With oil and fuel	XV19S(C)/ XV19M(C): 340.0 kg (750 lb) XV19CTS(C)/ XV19CTM(C): 364.0 kg (802 lb) XV19CS(C)/ XV19C(C): 331.0 kg (730 lb)
Maximum load	XV19S(C)/ XV19M(C): 210 kg (463 lb) XV19CTS(C)/ XV19CTM(C): 186 kg (410 lb) XV19CS(C)/ XV19C(C): 204 kg (450 lb)

EAS20290

ENGINE SPECIFICATIONS

Engine

Engine type	Air cooled 4-stroke, OHV
Displacement	1854.0 cm ³
Cylinder arrangement	V-type 2-cylinder
Bore × stroke	100.0 × 118.0 mm (3.94 × 4.65 in)
Compression ratio	9.48 :1
Starting system	Electric starter

Fuel

Recommended fuel	Premium unleaded gasoline only
Fuel tank capacity	XV19S(C)/ XV19M(C)/ XV19CTS(C)/ XV19CTM(C): 17.0 L (4.49 US gal) (3.74 Imp.gal)
	XV19CS(C)/ XV19C(C): 15.9 L (4.20 US gal) (3.50 Imp.gal)
Fuel reserve amount	XV19S(C)/ XV19M(C)/ XV19CTS(C)/ XV19CTM(C): 3.0 L (0.79 US gal) (0.66 Imp.gal)
	XV19CS(C)/ XV19C(C): 3.2 L (0.85 US gal) (0.70 Imp.gal)

Engine oil

Lubrication system	Dry sump
Type	YAMALUBE 4 (20W40) or SAE20W40
Recommended engine oil grade	API service SG type or higher, JASO standard MA
Engine oil quantity	
Total amount	5.20 L (5.50 US qt) (4.58 Imp.qt)
Engine	3.2 L (3.38 US qt) (2.82 Imp.qt)
Oil tank	2.0 L (2.11 US qt) (1.76 Imp.qt)
Without oil filter cartridge replacement	4.10 L (4.33 US qt) (3.61 Imp.qt)
With oil filter cartridge replacement	4.90 L (5.18 US qt) (4.31 Imp.qt)
Oil pressure (hot)	60.0 kPa/900 r/min (8.7 psi/900 r/min) (0.60 kgf/cm ² /900 r/min)

Transfer gear oil

Type	SAE80 API GL-4 Hypoid gear oil
Quantity (disassembled)	0.60 L (0.63 US qt) (0.53 Imp.qt)
Quantity	0.55 L (0.58 US qt) (0.48 Imp.qt)

Oil filter

Oil filter type	Cartridge (paper)
-----------------	-------------------

Oil pump

Oil pump type	Trochoid
Inner-rotor-to-outer-rotor-tip clearance	Less than 0.12 mm (0.0047 in)
Limit	0.20 mm (0.0079 in)
Outer-rotor-to-oil-pump-housing clearance	0.09–0.19 mm (0.0035–0.0075 in)
Limit	0.26 mm (0.0102 in)

ENGINE SPECIFICATIONS

Oil-pump-housing-to-inner-and-outer-rotor clearance	0.06–0.13 mm (0.0024–0.0051 in)
Limit	0.20 mm (0.0079 in)
Bypass valve opening pressure	80.0–120.0 kPa (11.6–17.4 psi) (0.80–1.20 kgf/cm ²)
Relief valve operating pressure	600.0 kPa (87.0 psi) (6.00 kgf/cm ²)

Transfer gear oil pump

Oil pump type	Trochoid
Inner-rotor-to-outer-rotor-tip clearance	Less than 0.12 mm (0.0047 in)
Limit	0.20 mm (0.0079 in)
Outer-rotor-to-oil-pump-housing clearance	0.10–0.15 mm (0.0039–0.0059 in)
Limit	0.22 mm (0.0087 in)
Oil-pump-housing-to-inner-and-outer-rotor clearance	0.04–0.09 mm (0.0016–0.0035 in)
Limit	0.160 mm (0.0063 in)

Spark plug (s)

Manufacturer/model	NGK/DPR8EA-9
Manufacturer/model	DENSO/X24EPR-U9
Spark plug gap	0.8–0.9 mm (0.031–0.035 in)

Cylinder head

Volume	80.90–84.90 cm ³ (4.94–5.18 cu.in)
Warpage limit	0.03 mm (0.0012 in)

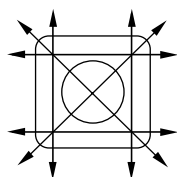

Camshaft

Drive system	Gear drive
Crankcase hole inside diameter	25.000–25.021 mm (0.9843–0.9851 in)
Camshaft journal diameter (crankcase side)	24.957–24.980 mm (0.9826–0.9835 in)
Camshaft to crankcase clearance	0.020–0.064 mm (0.0008–0.0025 in)
Camshaft cover hole inside diameter	28.000–28.021 mm (1.1024–1.1032 in)
Camshaft journal diameter (camshaft cover side)	27.957–27.980 mm (1.1007–1.1016 in)
Camshaft to camshaft cover clearance	0.020–0.064 mm (0.0008–0.0025 in)
Camshaft lobe dimensions	
Intake A	42.532–42.632 mm (1.6745–1.6784 in)
Limit	42.432 mm (1.6705 in)
Intake B	35.950–36.050 mm (1.4154–1.4193 in)
Limit	35.850 mm (1.4114 in)
Exhaust A	42.530–42.630 mm (1.6744–1.6783 in) (cylinder #1)
	42.531–42.631 mm (1.6744–1.6784 in) (cylinder #2)
Limit	42.430 mm (1.6705 in) (cylinder #1)
	42.431 mm (1.6705 in) (cylinder #2)
Exhaust B	35.950–36.050 mm (1.4154–1.4193 in)

ENGINE SPECIFICATIONS

Limit

35.850 mm (1.4114 in)

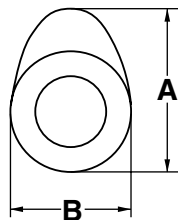

Rocker arm/rocker arm shaft

Rocker arm inside diameter	18.000–18.018 mm (0.7087–0.7094 in)
Limit	18.036 mm (0.7101 in)
Rocker arm shaft outside diameter	17.976–17.991 mm (0.7077–0.7083 in)
Rocker-arm-to-rocker-arm-shaft clearance	0.009–0.042 mm (0.0004–0.0017 in)
Limit	0.080 mm (0.0032 in)

Valve, valve seat, valve guide

Valve clearance (cold)	
Intake	0.00–0.04 mm (0.0000–0.0016 in)
Exhaust	0.00–0.04 mm (0.0000–0.0016 in)
Valve dimensions	
Valve head diameter A (intake)	35.90–36.10 mm (1.4134–1.4213 in)
Valve head diameter A (exhaust)	30.90–31.10 mm (1.2165–1.2244 in)

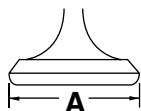

Valve seat width C (intake)	1.10–1.30 mm (0.0433–0.0512 in)
Limit	2.0 mm (0.08 in)
Valve seat width C (exhaust)	1.10–1.30 mm (0.0433–0.0512 in)
Limit	2.0 mm (0.08 in)

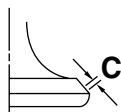

Valve margin thickness D (intake)	1.15–1.45 mm (0.0453–0.0571 in)
Limit	0.4 mm (0.02 in)
Valve margin thickness D (exhaust)	1.15–1.45 mm (0.0453–0.0571 in)
Limit	0.4 mm (0.02 in)

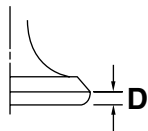

Valve stem diameter (intake)	5.975–5.990 mm (0.2352–0.2358 in)
Limit	5.945 mm (0.2341 in)
Valve stem diameter (exhaust)	5.960–5.975 mm (0.2346–0.2352 in)
Limit	5.920 mm (0.2331 in)
Valve guide inside diameter (intake)	6.000–6.012 mm (0.2362–0.2367 in)
Limit	6.050 mm (0.2382 in)
Valve guide inside diameter (exhaust)	6.000–6.012 mm (0.2362–0.2367 in)

ENGINE SPECIFICATIONS

Limit	6.050 mm (0.2382 in)
Valve-stem-to-valve-guide clearance (intake)	0.010–0.037 mm (0.0004–0.0015 in)
Limit	0.080 mm (0.0032 in)
Valve-stem-to-valve-guide clearance (exhaust)	0.025–0.052 mm (0.0010–0.0020 in)
Limit	0.100 mm (0.0039 in)
Valve stem runout	0.010 mm (0.0004 in)

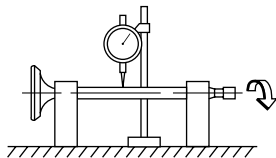

Valve spring

Free length (intake)	46.71 mm (1.84 in)
Limit	44.71 mm (1.76 in)
Free length (exhaust)	46.71 mm (1.84 in)
Limit	44.71 mm (1.76 in)
Installed length (intake)	32.66 mm (1.29 in)
Installed length (exhaust)	32.66 mm (1.29 in)
Spring rate K1 (intake)	16.58 N/mm (94.67 lb/in) (1.69 kgf/mm)
Spring rate K2 (intake)	21.98 N/mm (125.51 lb/in) (2.24 kgf/mm)
Spring rate K1 (exhaust)	16.58 N/mm (94.67 lb/in) (1.69 kgf/mm)
Spring rate K2 (exhaust)	21.98 N/mm (125.51 lb/in) (2.24 kgf/mm)
Installed compression spring force (intake)	217.00–249.00 N (48.78–55.98 lb) (22.13–25.39 kgf)
Installed compression spring force (exhaust)	217.00–249.00 N (48.78–55.98 lb) (22.13–25.39 kgf)
Spring tilt (intake)	2.5 °/2.0 mm
Spring tilt (exhaust)	2.5 °/2.0 mm

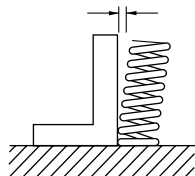

Winding direction (intake)	Clockwise
Winding direction (exhaust)	Clockwise

Valve lifter

Valve lifter outside diameter (intake)	22.962–22.974 mm (0.9040–0.9045 in)
Valve lifter outside diameter (exhaust)	22.962–22.974 mm (0.9040–0.9045 in)
Valve lifter hole inside diameter (intake)	23.000–23.021 mm (0.9055–0.9063 in)
Valve lifter hole inside diameter (exhaust)	23.000–23.021 mm (0.9055–0.9063 in)
Valve-lifter-to-valve-lifter-hole clearance	0.026–0.059 mm (0.0010–0.0023 in)

Valve push rod

Valve push rod 1 length	286.5 mm (11.280 in)
Valve push rod 2 length	288.5 mm (11.358 in)
Valve push rod runout	0.3 mm (0.012 in)

ENGINE SPECIFICATIONS

Cylinder

Bore	100.000–100.010 mm (3.9370–3.9374 in)
Taper limit	0.050 mm (0.0020 in)
Out of round limit	0.050 mm (0.0020 in)

Piston

Piston-to-cylinder clearance	0.025–0.050 mm (0.0010–0.0020 in)
Limit	0.15 mm (0.0059 in)
Diameter D	99.960–99.975 mm (3.9354–3.9360 in)
Height H	10.0 mm (0.39 in)

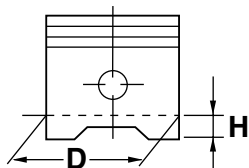

Offset	0.50 mm (0.0197 in)
Piston pin bore inside diameter	23.004–23.015 mm (0.9057–0.9061 in)
Limit	23.045 mm (0.9073 in)
Piston pin outside diameter	22.991–23.000 mm (0.9052–0.9055 in)
Limit	22.971 mm (0.9044 in)
Piston-pin-to-piston-pin-bore clearance	0.004–0.024 mm (0.00016–0.00094 in)
Limit	0.074 mm (0.00291 in)

Piston ring

Top ring

Ring type	Barrel
Dimensions (B × T)	1.20 × 3.80 mm (0.05 × 0.15 in)

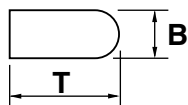

End gap (installed)	0.20–0.35 mm (0.0079–0.0138 in)
Limit	0.55 mm (0.0217 in)
Ring side clearance	0.030–0.080 mm (0.0012–0.0032 in)
Limit	0.120 mm (0.0047 in)

2nd ring

Ring type	Taper
Dimensions (B × T)	1.20 × 4.00 mm (0.05 × 0.16 in)

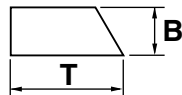

End gap (installed)	0.45–0.60 mm (0.0177–0.0236 in)
Limit	0.95 mm (0.0374 in)
Ring side clearance	0.030–0.070 mm (0.0012–0.0028 in)
Limit	0.120 mm (0.0047 in)

ENGINE SPECIFICATIONS

Oil ring	
Dimensions (B × T)	2.50 × 3.40 mm (0.10 × 0.13 in)

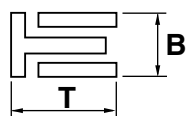

End gap (installed)	0.20–0.70 mm (0.0079–0.0276 in)
---------------------	---------------------------------

Connecting rod

Oil clearance (using plastigauge®)	0.050–0.074 mm (0.0020–0.0029 in)
Bearing color code	1.Blue 2.Black 3.Brown 4.Green 5.Yellow

Crankshaft

Width A	105.80–106.20 mm (4.165–4.181 in)
Runout limit C	0.040 mm (0.0016 in)
Big end side clearance D	0.320–0.474 mm (0.0126–0.0187 in)
Big end radial clearance E	0.037–0.074 mm (0.0015–0.0029 in)
Limit	0.09 mm (0.0035 in)

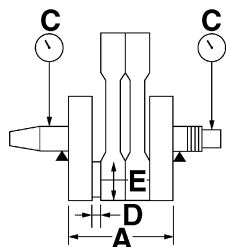

Journal oil clearance (using plastigauge®)	0.030–0.062 mm (0.0012–0.0024 in)
Limit	0.10 mm (0.0039 in)

Clutch

Clutch type	Wet, multiple-disc
Clutch release method	Hydraulic inner push
Operation	Left hand operation
Friction plate 1, 3 thickness	2.90–3.10 mm (0.114–0.122 in)
Wear limit	2.80 mm (0.110 in)
Plate quantity	10 pcs
Friction plate 2 thickness	2.92–3.08 mm (0.115–0.121 in)
Wear limit	2.82 mm (0.111 in)
Plate quantity	1 pcs
Clutch plate thickness	1.90–2.10 mm (0.075–0.083 in)
Plate quantity	10 pcs
Warping limit	0.20 mm (0.0079 in)
Clutch spring free length	6.78 mm (0.27 in)
Minimum length	6.28 mm (0.25 in)
Spring quantity	1 pcs
Clutch housing thrust clearance	0.100–0.110 mm (0.0039–0.0043 in)
Clutch housing radial clearance	0.020–0.066 mm (0.0008–0.0026 in)

Transmission

Transmission type	Constant mesh 5-speed
Primary reduction system	Spur gear
Primary reduction ratio	72/51 (1.412)

ENGINE SPECIFICATIONS

Secondary reduction system	Belt drive
Secondary reduction ratio	XV19SX(C)/ XV19MX(C)/ XV19CTSX(C)/ XV19CTMX(C): 70/31 (2.258) XV19CS(C)/ XV19C(C): 66/31 (2.129)
Operation	Left foot operation
Gear ratio	
1st	38/16 (2.375)
2nd	33/21 (1.571)
3rd	29/25 (1.160)
4th	26/28 (0.929)
5th	24/30 (0.800)
Main axle runout limit	0.08 mm (0.0032 in)
Drive axle runout limit	0.08 mm (0.0032 in)

Shifting mechanism	
Shift mechanism type	Guide bar
Shift fork guide bar bending limit	0.025 mm (0.0010 in)
Shift fork thickness	6.26–6.39 mm (0.2465–0.2516 in)

Air filter	
Air filter element	Oil-coated paper element

Fuel pump	
Pump type	Electrical
Model/manufacturer	1D7/MITSUBISHI
Maximum consumption amperage	5.5 A
Output pressure	441.0–637.0 kPa (63.9–92.4 psi) (4.41–6.37 kgf/cm ²)

Fuel injection	
Model/quantity	INP-101/2
Manufacturer	NIPPON INJECTOR

Throttle body	
Type/quantity	AC43/2
Manufacturer	MIKUNI
ID mark	XV19SX/ XV19MX/ XV19CTSX/ XV19CTMX: 1D71 00 XV19SXC/ XV19MXC/ XV19CTSXC/ XV19CTMXC: 1D72 10 XV19CX/ XV19CSX: 5C71 00 XV19CXC/ XV19CSXC: 5C72 10
Throttle valve size	#100

ENGINE SPECIFICATIONS

Throttle position sensor

Resistance	XV19S(C)/ XV19M(C)/ XV19CTS(C)/ XV19CTM(C): 4.0–6.0 k Ω /blue-black XV19CS(C)/ XV19C(C): 3.1–5.7 k Ω /blue-black
Output voltage (at idle)	0.63–0.73 V

Fuel injection sensor

Crankshaft position sensor resistance	248–372 Ω
Intake air pressure sensor output voltage	3.75–4.25 V
Engine temperature sensor resistance	0.90–1.10 k Ω at 100 °C (212 °F)

Idling condition

Engine idling speed	850–950 r/min
Intake vacuum	31.3–35.3 kPa (9.2–10.4 inHg) (235–265 mmHg)
Oil temperature	80.0–90.0 °C (176.00–194.00 °F)
Throttle cable free play	4.0–6.0 mm (0.16–0.24 in)

CHASSIS SPECIFICATIONS

EAS20300

CHASSIS SPECIFICATIONS

Chassis

Frame type	Double cradle
Caster angle	XV19S(C)/ XV19M(C)/ XV19CTS(C)/ XV19CTM(C): 31.30 ° XV19CS(C)/ XV19C(C): 33.20 °
Trail	XV19S(C)/ XV19M(C)/ XV19CTS(C)/ XV19CTM(C): 152.0 mm (5.98 in) XV19CS(C)/ XV19C(C): 102.0 mm (4.02 in)

Front wheel

Wheel type	Cast wheel
Rim size	XV19S(C)/ XV19M(C)/ XV19CTS(C)/ XV19CTM(C): 18M/C × MT4.00 XV19CS(C)/ XV19C(C): 21M/C × MT3.50
Rim material	Aluminum
Wheel travel	130.0 mm (5.12 in)
Radial wheel runout limit	1.0 mm (0.04 in)
Lateral wheel runout limit	0.5 mm (0.02 in)

Rear wheel

Wheel type	Cast wheel
Rim size	XV19S(C)/ XV19M(C)/ XV19CTS(C)/ XV19CTM(C): 17M/C × MT5.50 XV19CS(C)/ XV19C(C): 18M/C × MT7.50
Rim material	Aluminum
Wheel travel	XV19S(C)/ XV19M(C)/ XV19CTS(C)/ XV19CTM(C): 110.0 mm (4.33 in) XV19CS(C)/ XV19C(C): 90.0 mm (3.54 in)
Radial wheel runout limit	1.0 mm (0.04 in)
Lateral wheel runout limit	0.5 mm (0.02 in)

Front tire

Type	Tubeless
Size	XV19S(C)/ XV19M(C)/ XV19CTS(C)/ XV19CTM(C): 130/70R18M/C 63H XV19CS(C)/ XV19C(C): 120/70-21M/C 62H

CHASSIS SPECIFICATIONS

Manufacturer/model	XV19S(C)/ XV19M(C)/ XV19CTS(C)/ XV19CTM(C): DUNLOP/D251F
Manufacturer/model	XV19S(C)/ XV19M(C)/ XV19CTS(C)/ XV19CTM(C): BRIDGESTONE/G851 RADIAL G
Manufacturer/model	XV19CS(C)/ XV19C(C): METZELER/880 MARATHON
Wear limit (front)	1.0 mm (0.04 in)

Rear tire

Type	Tubeless
Size	XV19S(C)/ XV19M(C)/ XV19CTS(C)/ XV19CTM(C): 190/60R17M/C 78H XV19CS(C)/ XV19C(C): 210/40R18M/C 73H
Manufacturer/model	XV19S(C)/ XV19M(C)/ XV19CTS(C)/ XV19CTM(C): DUNLOP/D251
Manufacturer/model	XV19S(C)/ XV19M(C)/ XV19CTS(C)/ XV19CTM(C): BRIDGESTONE/G850 RADIAL G
Manufacturer/model	XV19CS(C)/ XV19C(C): METZELER/880 MARATHON
Wear limit (rear)	1.0 mm (0.04 in)

Tire air pressure (measured on cold tires)

Loading condition	0–90 kg (0–198 lb)
Front	250 kPa (36 psi) (2.50 kgf/cm ²)
Rear	280 kPa (41 psi) (2.80 kgf/cm ²)
Loading condition	XV19S(C)/ XV19M(C): 90–210 kg (198–463 lb)
	XV19CTS(C)/ XV19CTM(C): 90–186 kg (198–410 lb)
	XV19CS(C)/ XV19C(C) 90–204 kg (198–450 lb)
Front	250 kPa (36 psi) (2.50 kgf/cm ²)
Rear	280 kPa (41 psi) (2.80 kgf/cm ²)
High-speed riding	
Front	250 kPa (36 psi) (2.50 kgf/cm ²)
Rear	280 kPa (41 psi) (2.80 kgf/cm ²)

Front brake

Type	Dual disc brake
Operation	Right hand operation
Front disc brake	
Disc outside diameter × thickness	298.0 × 5.0 mm (11.73 × 0.20 in)
Brake disc thickness limit	4.5 mm (0.18 in)
Brake disc deflection limit	0.10 mm (0.0039 in)
Brake pad lining thickness (inner)	5.5 mm (0.22 in)
Limit	0.5 mm (0.02 in)
Brake pad lining thickness (outer)	5.5 mm (0.22 in)

CHASSIS SPECIFICATIONS

Limit	0.5 mm (0.02 in)
Master cylinder inside diameter	14.00 mm (0.55 in)
Caliper cylinder inside diameter	27.00 mm (1.06 in)
Caliper cylinder inside diameter	30.23 mm (1.19 in)
Recommended fluid	DOT 4

Rear brake

Type	Single disc brake
Operation	Right foot operation
Brake pedal position	XV19S(C)/ XV19M(C)/ XV19CTS(C)/ XV19CTM(C): 110.0 mm (4.33 in) XV19CS(C)/ XV19C(C): 93.0 mm (3.66 in)

Rear disc brake

Disc outside diameter × thickness	XV19S(C)/ XV19M(C)/ XV19CTS(C)/ XV19CTM(C): 320.0 × 6.0 mm (12.60 × 0.24 in) XV19CS(C)/ XV19C(C): 310.0 × 6.0 mm (12.20 × 0.24 in)
Brake disc thickness limit	5.5 mm (0.22 in)
Brake disc deflection limit	0.15 mm (0.0059 in)
Brake pad lining thickness (inner)	5.8 mm (0.23 in)
Limit	0.8 mm (0.03 in)
Brake pad lining thickness (outer)	5.8 mm (0.23 in)
Limit	0.8 mm (0.03 in)
Master cylinder inside diameter	12.7 mm (0.50 in)
Caliper cylinder inside diameter	41.30 mm (1.63 in)
Recommended fluid	DOT 4

Steering

Steering bearing type	Taper roller bearing
Lock to lock angle (left)	35.0 °
Lock to lock angle (right)	35.0 °

Front suspension

Type	Telescopic fork
Spring/shock absorber type	Coil spring/oil damper
Front fork travel	130.0 mm (5.12 in)
Fork spring free length	XV19S(C)/ XV19M(C)/ XV19CTS(C)/ XV19CTM(C): 273.9 mm (10.78 in) XV19CS(C)/ XV19C(C): 407.0 mm (16.02 in)
Limit	XV19S(C)/ XV19M(C)/ XV19CTS(C)/ XV19CTM(C): 268.4 mm (10.57 in) XV19CS(C)/ XV19C(C): 398.9 mm (15.70 in)
Collar length	230.0 mm (9.06 in)

CHASSIS SPECIFICATIONS

Installed length	XV19S(C)/ XV19M(C)/ XV19CTS(C)/ XV19CTM(C): 268.9 mm (10.59 in) XV19CS(C)/ XV19C(C): 402.0 mm (15.83 in)
Spring rate K1	XV19S(C)/ XV19M(C)/ XV19CTS(C)/ XV19CTM(C): 10.0 N/mm (57.1 lb/in) (1.02 kgf/mm) XV19CS(C)/ XV19C(C): 8.34 N/mm (47.0 lb/in) (0.84 kgf/mm)
Spring stroke K1	XV19S(C)/ XV19M(C)/ XV19CTS(C)/ XV19CTM(C): 0.0–30.0 mm (0.00–1.18 in) XV19CS(C)/ XV19C(C): 130.0 mm (5.12 in)
Spring rate K2	XV19S(C)/ XV19M(C)/ XV19CTS(C)/ XV19CTM(C): 12.0 N/mm (68.5 lb/in) (1.22 kgf/mm)
Spring stroke K2	XV19S(C)/ XV19M(C)/ XV19CTS(C)/ XV19CTM(C): 30.0–130.0 mm (1.18–5.12 in)
Inner tube outer diameter	46.0 mm (1.81 in)
Inner tube bending limit	0.2 mm (0.01 in)
Optional spring available	No
Recommended oil	Yamaha fork oil 10WT
Quantity	XV19S(C)/ XV19M(C)/ XV19CTS(C)/ XV19CTM(C): 571.0 cm ³ (19.31 US oz) (20.10 Imp.oz) XV19CS(C)/ XV19C(C): 755.0 cm ³ (25.53 US oz) (26.58 Imp.oz)
Level	XV19S(C)/ XV19M(C)/ XV19CTS(C)/ XV19CTM(C): 124.0 mm (4.88 in) XV19CS(C)/ XV19C(C): 117.0 mm (4.61 in)

Rear suspension

Type	Swingarm (link suspension)
Spring/shock absorber type	Coil spring/gas-oil damper
Rear shock absorber assembly travel	XV19S(C)/ XV19M(C)/ XV19CTS(C)/ XV19CTM(C): 50.0 mm (1.97 in) XV19CS(C)/ XV19C(C): 40.0 mm (1.57 in)
Spring free length	XV19S(C)/ XV19M(C)/ XV19CTS(C)/ XV19CTM(C): 180.0 mm (7.09 in) XV19CS(C)/ XV19C(C): 187.0 mm (7.36 in)

CHASSIS SPECIFICATIONS

Limit	XV19S(C)/ XV19M(C)/ XV19CTS(C)/ XV19CTM(C): 176.4 mm (6.94 in)
Installed length	XV19CS(C)/ XV19C(C): 183.3 mm (7.22 in) XV19S(C)/ XV19M(C): 171.0 mm (6.73 in) XV19CTS(C)/ XV19CTM(C): 165.0 mm (6.50 in) XV19CS(C)/ XV19C(C): 172 mm (6.77 in)
Spring rate K1	XV19S(C)/ XV19M(C)/ XV19CTS(C)/ XV19CTM(C): 176.50 N/mm (1007.82 lb/in) (18.00 kgf/mm)
Spring stroke K1	XV19CS(C)/ XV19C(C): 186.20 N/mm (1063.18 lb/in) (18.99 kgf/mm) XV19S(C)/ XV19M(C)/ XV19CTS(C)/ XV19CTM(C): 0.0–50.0 mm (0.00–1.97 in) XV19CS(C)/ XV19C(C): 0.0–40.0 mm (0.00–1.57 in)
Optional spring available	No
Enclosed gas/air pressure (STD)	0.98 MPa (139.4 psi) (9.8 kgf/cm ²)
Spring preload adjusting positions	Installed spring length
Minimum	XV19S(C)/ XV19M(C)/ XV19CTS(C)/ XV19CTM(C): 162.0 mm (6.38 in) XV19CS(C)/ XV19C(C): 163.0 mm (6.42 in)
Standard	XV19S(C)/ XV19M(C): 171.0 mm (6.73 in) XV19CTS(C)/ XV19CTM(C): 165.0 mm (6.50 in) XV19CS(C)/ XV19C(C): 172.0 mm (6.77 in)
Maximum	XV19S(C)/ XV19M(C)/ XV19CTS(C)/ XV19CTM(C): 171.0 mm (6.73 in) XV19CS(C)/ XV19C(C): 172.0 mm (6.77 in)

Swingarm

Swingarm end free play limit (radial)	1.0 mm (0.04 in)
Swingarm end free play limit (axial)	1.0 mm (0.04 in)

Drive belt

Model/manufacture	UBD-0732/GATES CORPORATION
Drive belt slack (on the sidestand)	7.5–13 mm (0.30–0.51 in)
Drive belt slack (on a suitable stand)	14–21 mm (0.55–0.83 in)

ELECTRICAL SPECIFICATIONS

EAS20310

ELECTRICAL SPECIFICATIONS

Voltage

System voltage 12 V

Ignition system

Ignition system Transistorized coil ignition (digital)
Advancer type Electrical
Ignition timing (B.T.D.C.) 10.0 °/900 r/min

Engine control unit

Model/manufacture
XV19S(C)/ XV19M(C)/ XV19CTS(C)/
XV19CTM(C):
F008T83271/MITSUBISHI
XV19CS(C)/ XV19C(C):
F008T83971/MITSUBISHI

Ignition coil

Model/manufacture 2JN/YAMAHA
Minimum ignition spark gap 6.0 mm (0.24 in)
Primary coil resistance 2.16–2.64 Ω
Secondary coil resistance 8.64–12.96 kΩ

Spark plug cap

Material Resin
Resistance 10.0 kΩ

AC magneto

Model/manufacture F4T38971/MITSUBISHI
Standard output 14.0 V 32.0 A 5000 r/min
Stator coil resistance 0.112–0.168 Ω

Rectifier/regulator

Regulator type Semi conductor-short circuit
Model/manufacture FH012AA/SHINDENGEN
No load regulated voltage 14.2–14.8 V
Rectifier capacity 50.0 A
Withstand voltage 40.0 V

Battery

Model GT14B-4
Voltage, capacity 12 V, 12.0 Ah
Manufacturer GS YUASA
Ten hour rate amperage 1.20 A

Headlight

Bulb type Halogen bulb

Bulb voltage, wattage × quantity

Low beam headlight XV19S(C)/ XV19M(C)/ XV19CTS(C)/
XV19CTM(C):
12 V, 51.0 W × 1

ELECTRICAL SPECIFICATIONS

High beam headlight	XV19S(C)/ XV19M(C)/ XV19CTS(C)/ XV19CTM(C): 12 V, 55.0 W × 1
Headlight	XV19CS(C)/ XV19C(C): 12 V, 60.0 W/55.0 W × 1
Tail/brake light	LED
Front turn signal/position light	12 V, 23 W/8.0 W × 2
Rear turn signal light	12 V, 21.0 W × 2
License plate light	XV19S(C)/ XV19M(C)/ XV19CTS(C)/ XV19CTM(C): 12 V, 5.0 W XV19CS(C)/ XV19C(C): 12 V, 3.8 W × 2
Meter lighting	LED

Indicator light

Neutral indicator light	LED
Turn signal indicator light	LED
High beam indicator light	LED
Fuel level warning light	LED
Engine trouble warning light	LED

Electric starting system

System type	Constant mesh
-------------	---------------

Starter motor

Model/manufacture	1D7/YAMAHA
Power output	0.90 kW
Armature coil resistance	0.0081–0.0099 Ω
Brush overall length	9.8 mm (0.39 in)
Limit	5.00 mm (0.20 in)
Brush spring force	7.36–11.04 N (26.49–39.74 oz) (750–1126 gf)
Commutator diameter	28.5 mm (1.12 in)
Limit	27.5 mm (1.08 in)
Mica undercut (depth)	1.50 mm (0.06 in)

Starter relay

Model/manufacture	2768079-A/JIDECO
Amperage	180.0 A
Coil resistance	4.18–4.62 Ω

Horn

Horn type	Eddy
Quantity	2 pcs
Model/manufacture	YP-12/NIKKO
Maximum amperage	2.0 A
Coil resistance	0.94–0.98 Ω
Performance	95–115 dB/2m

Turn signal relay

Relay type	Semi transistor
Model/manufacture	FB246H/DENSO
Built-in, self-canceling device	Yes

ELECTRICAL SPECIFICATIONS

Turn signal blinking frequency	75.0–95.0 cycles/min
Wattage	21(23) W × 2 + LED × 2

Fuel gauge	
Model/manufacturer	XV19S(C)/ XV19M(C)/ XV19CTS(C)/ XV19CTM(C) 1D7/YAMAHA XV19CS(C)/ XV19C(C): 5C7/NIPPON SEIKI
Sender unit resistance (full)	9–11 Ω
Sender unit resistance (empty)	213–219 Ω

Starting circuit cut-off relay	
Model/manufacturer	G8R-30Y-V3/OMRON
Coil resistance	162–198 Ω

Headlight relay	
Model/manufacturer	ACM33211M05/MATSUSHITA

Fuel pump relay	
Model/manufacturer	G8R-30Y-V3/OMRON
Coil resistance	162–198 Ω

Thermo unit	
Model/manufacturer	5PX/DENSO
Resistance at 100°C	898.4–1098.0 Ω

Fuses	
Main fuse	50.0 A
Headlight fuse	20.0 A
Taillight fuse	XV19S(C)/ XV19M(C)/ XV19CTS(C)/ XV19CTM(C): 10.0 A XV19CS(C)/ XV19C(C): 7.5 A
Signaling system fuse	10.0 A
Ignition fuse	25.0 A
Auxiliary DC connector fuse	3.0 A
ECU fuse	XV19S(C)/ XV19M(C)/ XV19CTS(C)/ XV19CTM(C): 10.0 A
Fuel injection system fuse	15.0 A
Backup fuse	XV19S(C)/ XV19M(C)/ XV19CTS(C)/ XV19CTM(C): 10.0 A XV19CS(C)/ XV19C(C): 7.5 A
Spare fuse	25.0 A
Spare fuse	20.0 A
Spare fuse	15.0 A
Spare fuse	10.0 A
Spare fuse	XV19CS(C)/ XV19C(C): 7.5 A

ELECTRICAL SPECIFICATIONS

Spare fuse

3.0 A

EAS20320

TIGHTENING TORQUES

EAS20330

GENERAL TIGHTENING TORQUE SPECIFICATIONS

This chart specifies tightening torques for standard fasteners with a standard ISO thread pitch. Tightening torque specifications for special components or assemblies are provided for each chapter of this manual. To avoid warpage, tighten multi-fastener assemblies in a crisscross pattern and progressive stages until the specified tightening torque is reached. Unless otherwise specified, tightening torque specifications require clean, dry threads. Components should be at room temperature.

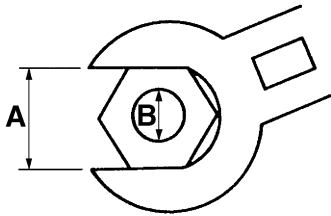















- A. Distance between flats
- B. Outside thread diameter

A (nut)	B (bolt)	General tightening torques		
		Nm	m·kg	ft·lb
10 mm	6 mm	6	0.6	4.3
12 mm	8 mm	15	1.5	11
14 mm	10 mm	30	3.0	22
17 mm	12 mm	55	5.5	40
19 mm	14 mm	85	8.5	61
22 mm	16 mm	130	13.0	94











TIGHTENING TORQUES

EAS20340















ENGINE TIGHTENING TORQUES

Item	Thread size	Q'ty	Tightening torque	Remarks
Cylinder head nut	M12	8	60 Nm (6.0 m·kg, 43 ft·lb)	
Cylinder head stud bolt (exhaust pipe)	M8	4	15 Nm (1.5 m·kg, 11 ft·lb)	
Spark plug	M12	4	18 Nm (1.8 m·kg, 13 ft·lb)	
Engine temperature sensor	—	1	20 Nm (2.0 m·kg, 14 ft·lb)	
Rocker arm base bolt	M6	4	10 Nm (1.0 m·kg, 7.2 ft·lb)	
Rocker arm base bolt	M8	8	24 Nm (2.4 m·kg, 17 ft·lb)	
Cylinder head cover bolt	M6	28	10 Nm (1.0 m·kg, 7.2 ft·lb)	
Connecting rod bolt (1st)	M8	4	15 Nm (1.5 m·kg, 11 ft·lb)	See NOTE. 
Connecting rod bolt (final)	M8	4	Specified angle 125–135°	See NOTE. 
Right balancer driven gear bolt	M10	1	40 Nm (4.0 m·kg, 29 ft·lb)	
Left balancer drive gear bolt	M10	1	40 Nm (4.0 m·kg, 29 ft·lb)	
Left balancer driven gear housing screw	M6	6	10 Nm (1.0 m·kg, 7.2 ft·lb)	
Left balancer weight bolt	M6	3	10 Nm (1.0 m·kg, 7.2 ft·lb)	
Left balancer idle gear shaft bolt	M6	3	10 Nm (1.0 m·kg, 7.2 ft·lb)	
Camshaft driven gear bolt	M10	1	60 Nm (6.0 m·kg, 43 ft·lb)	
Camshaft drive gear bolt	M10	1	60 Nm (6.0 m·kg, 43 ft·lb)	
Front cylinder camshaft gear bolt	M10	1	40 Nm (4.0 m·kg, 29 ft·lb)	
Locknut (rocker arm adjusting screw)	M7	4	20 Nm (2.0 m·kg, 14 ft·lb)	
Valve lifter case bolt	M6	4	10 Nm (1.0 m·kg, 7.2 ft·lb)	
Oil filter bolt	M18	1	70 Nm (7.0 m·kg, 50 ft·lb)	
Oil filter cartridge	M20	1	17 Nm (1.7 m·kg, 12 ft·lb)	
Oil pipe 1 union bolt	M10	2	21 Nm (2.1 m·kg, 15 ft·lb)	
Oil pipe 1 union bolt*1	M8	1	18 Nm (1.8 m·kg, 13 ft·lb)	
Oil pipe 1 union bolt*2	M8	1	17 Nm (1.7 m·kg, 12 ft·lb)	
Oil filter bracket bolt	M6	4	10 Nm (1.0 m·kg, 7.2 ft·lb)	
Oil pipe bolt	M6	2	10 Nm (1.0 m·kg, 7.2 ft·lb)	
Oil delivery pipe 2 bolt	M6	3	10 Nm (1.0 m·kg, 7.2 ft·lb)	
Engine oil pump driven gear stopper bolt	M6	2	10 Nm (1.0 m·kg, 7.2 ft·lb)	
Oil pipe 3 bolt	M6	5	10 Nm (1.0 m·kg, 7.2 ft·lb)	
Oil pump bolt (crankcase)	M8	3	24 Nm (2.4 m·kg, 17 ft·lb)	
Oil pipe 2 bolt	M6	3	10 Nm (1.0 m·kg, 7.2 ft·lb)	











TIGHTENING TORQUES

Item	Thread size	Q'ty	Tightening torque	Remarks
Oil pipe 4 bolt	M6	3	10 Nm (1.0 m·kg, 7.2 ft·lb)	
Oil pump housing cover 1 screw (crankcase)	M6	2	7 Nm (0.7 m·kg, 5.1 ft·lb)	
Oil pump housing cover 2 screw (crankcase)	M6	2	7 Nm (0.7 m·kg, 5.1 ft·lb)	
Throttle body joint clamp screw	M5	2	3 Nm (0.3 m·kg, 2.2 ft·lb)	
Pressure regulator bolt	M5	2	7 Nm (0.7 m·kg, 5.1 ft·lb)	
Intake manifold assembly bolt	M6	2	10 Nm (1.0 m·kg, 7.2 ft·lb)	
Fuel pipe bolt	M12	2	30 Nm (3.0 m·kg, 22 ft·lb)	
Rear exhaust pipe joint nut	M8	2	20 Nm (2.0 m·kg, 14 ft·lb)	
Rear exhaust pipe, rear exhaust pipe joint cover and rear exhaust pipe joint nut	M8	2	24 Nm (2.4 m·kg, 17 ft·lb)	
Front exhaust pipe nut	M8	2	20 Nm (2.0 m·kg, 14 ft·lb)	
Front exhaust pipe and rear exhaust pipe bolt	M8	1	20 Nm (2.0 m·kg, 14 ft·lb)	
Rear exhaust pipe and muffler bolt	M8	1	20 Nm (2.0 m·kg, 14 ft·lb)	
Locknut (EXUP cable)	M6	2	7 Nm (0.7 m·kg, 5.1 ft·lb)	
EXUP valve pulley cover bolt	M6	1	7 Nm (0.7 m·kg, 5.1 ft·lb)	
Rear exhaust pipe joint cover bolt	M6	3	10 Nm (1.0 m·kg, 7.2 ft·lb)	
Muffler and frame bolt*2	M8	1	20 Nm (2.0 m·kg, 14 ft·lb)	
Muffler and muffler bracket bolt*1	M8	3	29 Nm (2.9 m·kg, 21 ft·lb)	
Muffler and muffler bracket bolt*2	M8	2	29 Nm (2.9 m·kg, 21 ft·lb)	
Muffler bracket and frame bolt	M10	2	53 Nm (5.3 m·kg, 38 ft·lb)	
O ₂ sensor	M18	1	44 Nm (4.4 m·kg, 32 ft·lb)	
Crankcase stud bolt	M12	8	See NOTE.	
Crankcase bolt	M6	21	10 Nm (1.0 m·kg, 7.2 ft·lb)	
Crankcase bolt	M8	3	24 Nm (2.4 m·kg, 17 ft·lb)	
Oil baffle plate bolt (left crankcase)	M6	6	10 Nm (1.0 m·kg, 7.2 ft·lb)	
Crankcase stud bolt*1	M10	1	See NOTE.	
Crankcase stud bolt*2	M10	1	15 Nm (1.5 m·kg, 11 ft·lb)	
Nozzle	M6	4	0.5 Nm (0.05 m·kg, 0.36 ft·lb)	
Oil gallery screw	M6	2	10 Nm (1.0 m·kg, 7.2 ft·lb)	
Bearing housing bolt (torque limiter)	M6	3	10 Nm (1.0 m·kg, 7.2 ft·lb)	
Oil gallery bolt	M8	4	20 Nm (2.0 m·kg, 14 ft·lb)	
Engine oil drain bolt (crankcase)	M14	2	43 Nm (4.3 m·kg, 31 ft·lb)	
Stator coil lead holder screw	M6	1	10 Nm (1.0 m·kg, 7.2 ft·lb)	

TIGHTENING TORQUES

Item	Thread size	Q'ty	Tightening torque	Remarks
Crankshaft position sensor lead holder screw	M6	6	10 Nm (1.0 m·kg, 7.2 ft·lb)	
Clutch cover damper plate screw	M6	4	10 Nm (1.0 m·kg, 7.2 ft·lb)	
Camshaft cover bolt	M6	8	10 Nm (1.0 m·kg, 7.2 ft·lb)	
Generator cover damper bolt	M5	3	5 Nm (0.5 m·kg, 3.6 ft·lb)	
Engine oil filler plug	M20	1	10 Nm (1.0 m·kg, 7.2 ft·lb)	
Camshaft sprocket cover plate bolt	M6	2	10 Nm (1.0 m·kg, 7.2 ft·lb)	
Oil baffle plate bolt (right crank-case)	M6	3	10 Nm (1.0 m·kg, 7.2 ft·lb)	
Clutch cover plate bolt	M6	3	10 Nm (1.0 m·kg, 7.2 ft·lb)	
Generator cover bolt	M6	10	10 Nm (1.0 m·kg, 7.2 ft·lb)	
Camshaft sprocket cover bolt	M6	8	10 Nm (1.0 m·kg, 7.2 ft·lb)	
Clutch cover bolt	M6	18	10 Nm (1.0 m·kg, 7.2 ft·lb)	
Oil gallery bolt*1	M6	2	10 Nm (1.0 m·kg, 7.2 ft·lb)	
Oil gallery bolt*2	M6	2	8 Nm (0.8 m·kg, 5.8 ft·lb)	
Clutch cover damper plate bolt	M5	3	5 Nm (0.5 m·kg, 3.6 ft·lb)	
Clutch cover damper bolt	M6	3	10 Nm (1.0 m·kg, 7.2 ft·lb)	
Starter clutch bolt	M8	6	24 Nm (2.4 m·kg, 17 ft·lb)	
Generator rotor bolt	M12	1	80 Nm (8.0 m·kg, 58 ft·lb)	
Starter motor bolt	M6	2	10 Nm (1.0 m·kg, 7.2 ft·lb)	
Primary drive gear bolt*1	M12	1	100 Nm (10.0 m·kg, 72 ft·lb)	
Primary drive gear bolt*2	M12	1	85 Nm (8.5 m·kg, 51 ft·lb)	
Clutch boss nut	M20	1	105 Nm (10.5 m·kg, 75 ft·lb)	Stake 
Clutch spring plate retainer bolt	M6	6	8 Nm (0.8 m·kg, 5.8 ft·lb)	
Bleed screw (clutch release cylinder)	M8	1	6 Nm (0.6 m·kg, 4.3 ft·lb)	
Clutch release cylinder bolt	M6	3	10 Nm (1.0 m·kg, 7.2 ft·lb)	
Drive axle bearing retainer screw	M8	2	20 Nm (2.0 m·kg, 14 ft·lb)	Stake
Main axle bearing retainer screw*1	M6	2	10 Nm (1.0 m·kg, 7.2 ft·lb)	
Main axle bearing retainer screw*2	M6	2	12 Nm (1.2 m·kg, 8.7 ft·lb)	
Engine oil drain bolt (oil tank)	M14	1	43 Nm (4.3 m·kg, 31 ft·lb)	
Transfer gear oil drain bolt	M8	1	18 Nm (1.8 m·kg, 13 ft·lb)	
Middle drive gear nut	M22	1	140 Nm (14.0 m·kg, 100 ft·lb)	Stake 
Transfer gear case oil pump assembly nut	M10	1	40 Nm (4.0 m·kg, 29 ft·lb)	

TIGHTENING TORQUES

Item	Thread size	Q'ty	Tightening torque	Remarks
Transfer gear case oil pump assembly bolt	M6	3	10 Nm (1.0 m·kg, 7.2 ft·lb)	
Oil pump housing screw (transfer gear case)	M5	2	4 Nm (0.4 m·kg, 2.9 ft·lb)	
Transfer gear oil check bolt	M6	1	8 Nm (0.8 m·kg, 5.8 ft·lb)	
Transfer gear case bolt	M10	4	50 Nm (5.0 m·kg, 36 ft·lb)	
Dipstick joint bolt	M6	2	10 Nm (1.0 m·kg, 7.2 ft·lb)	
Drive pulley case bolt	M12	8	70 Nm (7.0 m·kg, 50 ft·lb)	
Oil strainer bolt (oil tank)	M6	1	10 Nm (1.0 m·kg, 7.2 ft·lb)	
Oil pipe 5 bolt	M6	1	10 Nm (1.0 m·kg, 7.2 ft·lb)	
Transfer gear case cover plate bolt	M6	3	5 Nm (0.5 m·kg, 3.6 ft·lb)	
Transfer gear case cover bolt	M6	12	10 Nm (1.0 m·kg, 7.2 ft·lb)	
Oil tank cover bolt	M6	15	10 Nm (1.0 m·kg, 7.2 ft·lb)	
Oil tank bracket bolt	M8	2	28 Nm (2.8 m·kg, 20 ft·lb)	
Shift shaft spring stopper bolt	M8	1	22 Nm (2.2 m·kg, 16 ft·lb)	
Stopper lever bolt	M6	1	10 Nm (1.0 m·kg, 7.2 ft·lb)	
Crankshaft position sensor screw	M6	2	10 Nm (1.0 m·kg, 7.2 ft·lb)	
Neutral switch screw	M6	2	4 Nm (0.4 m·kg, 2.9 ft·lb)	
Stator coil screw	M6	3	10 Nm (1.0 m·kg, 7.2 ft·lb)	
Neutral switch lead clamp screw	M6	1	10 Nm (1.0 m·kg, 7.2 ft·lb)	
Speed sensor bolt	M6	1	10 Nm (1.0 m·kg, 7.2 ft·lb)	
Oil cooler bolt*1	M6	1	7 Nm (0.7 m·kg, 5.1 ft·lb)	
Oil cooler bracket bolt*1	M6	2	7 Nm (0.7 m·kg, 5.1 ft·lb)	
Oil cooler hose bolt*1	M6	8	7 Nm (0.7 m·kg, 5.1 ft·lb)	
Clutch hose union bolt	M10	2	30 Nm (3.0 m·kg, 22 ft·lb)	
Clutch pipe union bolt	M10	1	10 Nm (1.0 m·kg, 7.2 ft·lb)	
Clutch pipe holder bolt	M6	2	7 Nm (0.7 m·kg, 5.1 ft·lb)	
Clutch pipe joint nut	M10	1	19 Nm (1.9 m·kg, 13 ft·lb)	

*1 For XV19S(C)/ XV19M(C)/ XV19CTS(C)/ XV19CTM(C)

*2 For XV19CS(C)/ XV19C(C)

NOTE:

- Tighten the connecting rod bolts to 15 Nm (1.5 m·kg, 11 ft·lb), and then tighten them further to reach the specified angle 125–135°.
- Install the crankcase stud bolts (M12) so that their installed length is 141.5 mm (5.57 in).
- Install the crankcase stud bolts (M10) so that their installed length is 70.5 mm (2.78 in).

TIGHTENING TORQUES

Cylinder head tightening sequence:

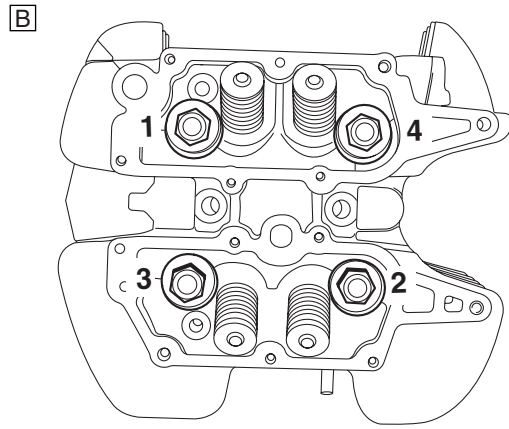
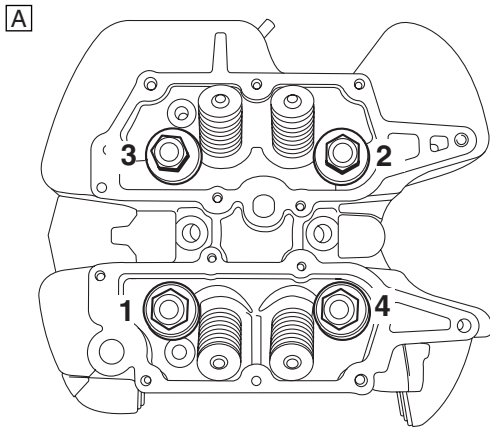







- A. Front cylinder
- B. Rear cylinder







TIGHTENING TORQUES

EAS20350













CHASSIS TIGHTENING TORQUES

Item	Thread size	Q'ty	Tightening torque	Remarks
Engine mounting bolt (left upper side)	M12	2	66 Nm (6.6 m·kg, 48 ft·lb)	
Engine mounting bolt (right upper side)*1, 2	M12	2	59 Nm (5.9 m·kg, 43 ft·lb)	
Engine mounting bolt (right upper side)*3	M12	2	66 Nm (6.6 m·kg, 48 ft·lb)	
Engine mounting nut (rear upper side)	M12	1	98 Nm (9.8 m·kg, 71 ft·lb)	
Engine mounting spacer bolt	M18	1	18 Nm (1.8 m·kg, 13 ft·lb)	
Engine bracket bolt (left upper side)	M10	2	53 Nm (5.3 m·kg, 38 ft·lb)	
Engine bracket bolt (right upper side)	M10	2	53 Nm (5.3 m·kg, 38 ft·lb)	
Engine bracket nut (rear upper side)	M10	2	53 Nm (5.3 m·kg, 38 ft·lb)	
Engine mounting nut (front upper side)	M12	1	98 Nm (9.8 m·kg, 71 ft·lb)	
Engine mounting nut (rear lower side)	M12	1	98 Nm (9.8 m·kg, 71 ft·lb)	
Engine mounting nut (front lower side)*1, 2	M12	1	105 Nm (10.5 m·kg, 75 ft·lb)	
Engine mounting nut (front lower side)*3	M12	1	90 Nm (9.0 m·kg, 65 ft·lb)	
Engine bracket nut (front upper side)	M10	4	53 Nm (5.3 m·kg, 38 ft·lb)	
Engine cross-member bracket bolt	M8	2	30 Nm (3.0 m·kg, 22 ft·lb)	
Engine bracket nut (rear lower side)	M10	3	58 Nm (5.8 m·kg, 42 ft·lb)	
Engine bracket bolt (right rear lower side)	M10	2	53 Nm (5.3 m·kg, 38 ft·lb)	
Transfer gear case bracket and transfer gear case bolt	M10	2	63 Nm (6.3 m·kg, 45 ft·lb)	
Transfer gear case bracket and frame bolt	M10	2	53 Nm (5.3 m·kg, 38 ft·lb)	
Cylinder-#1 ignition coil bolt	M6	4	7 Nm (0.7 m·kg, 5.1 ft·lb)	
Cylinder-#2 ignition coil bolt*1, 2	M6	4	7 Nm (0.7 m·kg, 5.1 ft·lb)	
Cylinder-#2 ignition coil bolt*3	M6	4	7 Nm (0.7 m·kg, 5.1 ft·lb)	
Lean angle sensor bolt*1, 2	M4	2	2 Nm (0.2 m·kg, 1.4 ft·lb)	
Lean angle sensor bolt*3	M4	2	2 Nm (0.2 m·kg, 1.4 ft·lb)	
Horn bolt*1, 2	M6	4	10 Nm (1.0 m·kg, 7.2 ft·lb)	
Horn 1 bolt*3	M6	2	10 Nm (1.0 m·kg, 7.2 ft·lb)	









TIGHTENING TORQUES

Item	Thread size	Q'ty	Tightening torque	Remarks
Horn 2 bolt*3	M6	2	10 Nm (1.0 m·kg, 7.2 ft·lb)	
ISC (idle speed control) unit bolt	M6	2	7 Nm (0.7 m·kg, 5.1 ft·lb)	
ISC (idle speed control) unit bracket bolt	M6	4	7 Nm (0.7 m·kg, 5.1 ft·lb)	
Pivot shaft nut	M18	1	125 Nm (12.5 m·kg, 90 ft·lb)	
Relay arm nut (relay arm and swingarm)	M12	1	59 Nm (5.9 m·kg, 43 ft·lb)	
Relay arm nut (relay arm and connecting arm)	M12	1	59 Nm (5.9 m·kg, 43 ft·lb)	
Rear shock absorber assembly nut (rear side)	M10	1	40 Nm (4.0 m·kg, 29 ft·lb)	
Rear shock absorber assembly nut (front side)	M12	1	59 Nm (5.9 m·kg, 43 ft·lb)	
Upper drive belt cover bolt	M6	2	7 Nm (0.7 m·kg, 5.1 ft·lb)	
Lower drive belt cover bolt	M6	2	7 Nm (0.7 m·kg, 5.1 ft·lb)	
Rear brake hose guide bolt	M6	2	7 Nm (0.7 m·kg, 5.1 ft·lb)	
Upper bracket pinch bolt*1, 2	M6	4	10 Nm (1.0 m·kg, 7.2 ft·lb)	
Upper bracket pinch bolt*3	M8	4	19 Nm (1.9 m·kg, 13 ft·lb)	
Headlight cover bolt*1, 2	M6	4	7 Nm (0.7 m·kg, 5.1 ft·lb)	
Headlight bracket and throttle cable guide bolt*1, 2	M6	2	10 Nm (1.0 m·kg, 7.2 ft·lb)	
Headlight body bolt*1, 2	M6	3	7 Nm (0.7 m·kg, 5.1 ft·lb)	
Headlight body bolt*3	M6	1	10 Nm (1.0 m·kg, 7.2 ft·lb)	
Headlight bracket bolt*3	M8	4	16 Nm (1.6 m·kg, 11 ft·lb)	
Headlight body and headlight bracket bolt*3	M6	2	10 Nm (1.0 m·kg, 7.2 ft·lb)	
Main switch cover bracket bolt*3	M6	2	7 Nm (0.7 m·kg, 5.1 ft·lb)	
Main switch cover bolt*3	M6	2	7 Nm (0.7 m·kg, 5.1 ft·lb)	
Main switch and cable guide bolt*3	M6	2	10 Nm (1.0 m·kg, 7.2 ft·lb)	
Front turn signal/position light bolt*3	M8	2	16 Nm (1.6 m·kg, 11 ft·lb)	
Front turn signal/position light pinch nut*3	M6	2	7 Nm (0.7 m·kg, 5.1 ft·lb)	
Air temperature sensor bracket bolt*3	M6	1	7 Nm (0.7 m·kg, 5.1 ft·lb)	
Steering stem nut*1, 2	M28	1	115 Nm (11.5 m·kg, 85 ft·lb)	
Steering stem bolt*3	M20	1	165 Nm (16.5 m·kg, 120 ft·lb)	
Upper handlebar holder bolt	M8	4	28 Nm (2.8 m·kg, 20 ft·lb)	
Lower ring nut (initial tightening torque)	M30	1	52 Nm (5.2 m·kg, 37 ft·lb)	See NOTE.







TIGHTENING TORQUES

Item	Thread size	Q'ty	Tightening torque	Remarks
Lower ring nut (final tightening torque)	M30	1	18 Nm (1.8 m·kg, 13 ft·lb)	See NOTE.
Hose guide and lower handlebar holder nut*1, 2	M10	2	32 Nm (3.2 m·kg, 23 ft·lb)	
Hose guide and lower handlebar holder nut*3	M12	2	40 Nm (4.0 m·kg, 29 ft·lb)	
Front brake master cylinder holder bolt	M6	2	10 Nm (1.0 m·kg, 7.2 ft·lb)	
Front brake hose union bolt (front brake master cylinder side)	M10	1	30 Nm (3.0 m·kg, 22 ft·lb)	
Clutch master cylinder holder bolt	M6	2	10 Nm (1.0 m·kg, 7.2 ft·lb)	
Grip end	M16	2	23 Nm (2.3 m·kg, 17 ft·lb)	
Lower handlebar holder nut*1, 2	M10	2	50 Nm (5.0 m·kg, 36 ft·lb)	
Upper bracket cover bolt*1, 2	M8	2	19 Nm (1.9 m·kg, 13 ft·lb)	
Upper bracket cover bolt*1, 2	M8	2	16 Nm (1.6 m·kg, 11 ft·lb)	
Front brake hose guide and front brake hose guide bracket bolt*1, 2	M6	4	10 Nm (1.0 m·kg, 7.2 ft·lb)	
Front brake hose holder and front brake hose holder bracket bolt*3	M6	2	10 Nm (1.0 m·kg, 7.2 ft·lb)	
Front brake hose guide and lower bracket bolt*1, 2	M6	1	10 Nm (1.0 m·kg, 7.2 ft·lb)	
Front brake hose guide and lower bracket bolt*3	M6	1	7 Nm (0.7 m·kg, 5.1 ft·lb)	
Front brake hose joint bolt*1, 2	M6	1	10 Nm (1.0 m·kg, 7.2 ft·lb)	
Plate bolt (front brake hose joint)*3	M6	1	7 Nm (0.7 m·kg, 5.1 ft·lb)	
Front brake hose joint bolt*3	M6	1	7 Nm (0.7 m·kg, 5.1 ft·lb)	
Front brake hose joint holder bolt*3	M6	2	7 Nm (0.7 m·kg, 5.1 ft·lb)	
Lower bracket cover bolt*3	M6	2	10 Nm (1.0 m·kg, 7.2 ft·lb)	
Bolt (lower bracket hole)*1, 3	M8	2	16 Nm (1.6 m·kg, 11 ft·lb)	
Front fender stay bolt*1, 2	M6	4	7 Nm (0.7 m·kg, 5.1 ft·lb)	
Front fender bolt	M8	6	16 Nm (1.6 m·kg, 11 ft·lb)	
Fuel sender bolt	M5	4	4 Nm (0.4 m·kg, 2.9 ft·lb)	
Fuel tank bracket bolt (front side)	M8	2	16 Nm (1.6 m·kg, 11 ft·lb)	
Fuel tank bracket 2 bolt (front side)*3	M8	2	16 Nm (1.6 m·kg, 11 ft·lb)	
Fuel tank bracket nut (rear side)	M6	2	10 Nm (1.0 m·kg, 7.2 ft·lb)	
Sub-fuel tank bolt	M6	3	10 Nm (1.0 m·kg, 7.2 ft·lb)	
Rider seat bracket bolt	M8	2	23 Nm (2.3 m·kg, 17 ft·lb)	









TIGHTENING TORQUES

Item	Thread size	Q'ty	Tightening torque	Remarks
Fuel tank and fuel tank bracket bolt (front side)	M6	2	7 Nm (0.7 m·kg, 5.1 ft·lb)	
Fuel tank and fuel tank bracket bolt (rear side)	M6	1	10 Nm (1.0 m·kg, 7.2 ft·lb)	
Meter cover bolt	M6	3	7 Nm (0.7 m·kg, 5.1 ft·lb)	
Fuel pump bolt	M5	6	5 Nm (0.5 m·kg, 3.6 ft·lb)	
Fuel return pipe holder bolt*1, 2	M6	1	7 Nm (0.7 m·kg, 5.1 ft·lb)	
Fuel return pipe holder bolt*3	M6	1	10 Nm (1.0 m·kg, 7.2 ft·lb)	
Fuel tank breather/overflow pipe holder bolt*3	M6	2	7 Nm (0.7 m·kg, 5.1 ft·lb)	
Air filter case bracket bolt*1, 2	M8	3	16 Nm (1.6 m·kg, 11 ft·lb)	
Air filter case bracket bolt*3	M8	1	17 Nm (1.7 m·kg, 12 ft·lb)	
Canister bolt*1, 2	M6	2	7 Nm (0.7 m·kg, 5.1 ft·lb)	For California only
Canister bolt*3	M6	2	10 Nm (1.0 m·kg, 7.2 ft·lb)	For California only 
Front wheel axle	M18	1	72 Nm (7.2 m·kg, 52 ft·lb)	
Front wheel axle pinch bolt	M8	1	23 Nm (2.3 m·kg, 17 ft·lb)	
Rear wheel axle nut	M18	1	150 Nm (15.0 m·kg, 110 ft·lb)	
Locknut (drive belt adjusting bolt)	M8	2	16 Nm (1.6 m·kg, 11 ft·lb)	
Front brake caliper bolt	M10	4	40 Nm (4.0 m·kg, 29 ft·lb)	
Front brake hose union bolt (front brake caliper side)	M10	2	32 Nm (3.2 m·kg, 23 ft·lb)	
Rear brake caliper bolt	M10	2	27 Nm (2.7 m·kg, 19 ft·lb)	
Front brake disc bolt*1, 2	M6	12	23 Nm (2.3 m·kg, 17 ft·lb)	
Front brake disc bolt*3	M8	10	23 Nm (2.3 m·kg, 17 ft·lb)	
Rear brake disc bolt	M6	6	18 Nm (1.8 m·kg, 13 ft·lb)	
Bleed screw (front brake caliper)	M8	2	6 Nm (0.6 m·kg, 4.3 ft·lb)	
Bleed screw (rear brake caliper)	M7	1	6 Nm (0.6 m·kg, 4.3 ft·lb)	
Rear wheel pulley nut	M12	5	95 Nm (9.5 m·kg, 68 ft·lb)	
Left side cover and sub-fuel tank bracket bolt	M6	1	7 Nm (0.7 m·kg, 5.1 ft·lb)	
Left side cover bolt	M6	1	10 Nm (1.0 m·kg, 7.2 ft·lb)	
Seat lock cable assembly bolt	M6	2	10 Nm (1.0 m·kg, 7.2 ft·lb)	
Lead holder bracket bolt	M6	2	10 Nm (1.0 m·kg, 7.2 ft·lb)	
Right side cover bolt	M6	1	10 Nm (1.0 m·kg, 7.2 ft·lb)	
Starter motor lead bolt (starter relay side)*1, 2	M6	1	7 Nm (0.7 m·kg, 5.1 ft·lb)	

TIGHTENING TORQUES

Item	Thread size	Q'ty	Tightening torque	Remarks
Positive battery lead bolt (starter relay side)*1, 2	M6	1	7 Nm (0.7 m·kg, 5.1 ft·lb)	
Starter motor lead bolt (starter relay side)*3	M6	1	5 Nm (0.5 m·kg, 3.6 ft·lb)	
Positive battery lead bolt (starter relay side)*3	M6	1	5 Nm (0.5 m·kg, 3.6 ft·lb)	
Rear fender bracket and frame bolt	M10	4	40 Nm (4.0 m·kg, 29 ft·lb)	
Rear fender bracket and frame bolt*1, 2	M10	2	40 Nm (4.0 m·kg, 29 ft·lb)	
Rear fender bracket and rear fender bolt	M8	4	23 Nm (2.3 m·kg, 17 ft·lb)	
Passenger seat bolt	M8	2	16 Nm (1.6 m·kg, 11 ft·lb)	
Rider seat bracket assembly and seat lock assembly bolt	M6	2	7 Nm (0.7 m·kg, 5.1 ft·lb)	
Tool kit and battery box bolt	M6	2	7 Nm (0.7 m·kg, 5.1 ft·lb)	
Pressure regulator bracket bolt*1, 2	M6	2	13 Nm (1.3 m·kg, 9.4 ft·lb)	
Pressure regulator bracket bolt*3	M8	2	16 Nm (1.6 m·kg, 11 ft·lb)	
Cylinder-#1 ignition coil cover bolt*1, 2	M6	2	7 Nm (0.7 m·kg, 5.1 ft·lb)	
Cylinder-#1 ignition coil bracket bolt*1, 2	M6	2	7 Nm (0.7 m·kg, 5.1 ft·lb)	
Right ignition coil cover bolt*3	M6	2	7 Nm (0.7 m·kg, 5.1 ft·lb)	
Right ignition coil bracket bolt*3	M6	2	7 Nm (0.7 m·kg, 5.1 ft·lb)	
License plate bolt*1, 2	M8	3	16 Nm (1.6 m·kg, 11 ft·lb)	
Sidestand bolt	M10	2	63 Nm (6.3 m·kg, 45 ft·lb)	
Rider footrest assembly bolt (left and right)	M10	4	48 Nm (4.8 m·kg, 35 ft·lb)	
Passenger footrest bolt (left and right)	M10	4	48 Nm (4.8 m·kg, 35 ft·lb)	
Rear brake master cylinder bracket and rear brake master cylinder bolt	M8	2	23 Nm (2.3 m·kg, 17 ft·lb)	
Rear brake master cylinder bracket and frame bolt	M8	2	23 Nm (2.3 m·kg, 17 ft·lb)	
Rear brake master cylinder cover bolt	M8	2	16 Nm (1.6 m·kg, 11 ft·lb)	
Brake fluid reservoir and frame bolt	M6	1	7 Nm (0.7 m·kg, 5.1 ft·lb)	
Rear brake hose union bolt	M10	2	30 Nm (3.0 m·kg, 22 ft·lb)	
Rear brake hose holder bolt	M6	1	7 Nm (0.7 m·kg, 5.1 ft·lb)	
Shift pedal shaft bracket bolt*1, 2	M8	2	16 Nm (1.6 m·kg, 11 ft·lb)	

TIGHTENING TORQUES

Item	Thread size	Q'ty	Tightening torque	Remarks
Locknut (shift rod)	M8	2	12 Nm (1.2 m·kg, 8.7 ft·lb)	
Shift arm bolt	M6	1	12 Nm (1.2 m·kg, 8.7 ft·lb)	
Shift pedal bolt (toe side)*1, 2	M6	1	14 Nm (1.4 m·kg, 10 ft·lb)	
Shift pedal bolt (heel side)*1, 2	M6	1	13 Nm (1.3 m·kg, 9.4 ft·lb)	
Shift pedal bolt*3	M8	1	30 Nm (3.0 m·kg, 22 ft·lb)	
Lower bracket pinch bolt	M8	4	23 Nm (2.3 m·kg, 17 ft·lb)	
Cap bolt	M43	2	23 Nm (2.3 m·kg, 17 ft·lb)	
Damper rod assembly	M12	2	40 Nm (4.0 m·kg, 29 ft·lb)	
Lower front fork cover nut*1, 2	M6	4	7 Nm (0.7 m·kg, 5.1 ft·lb)	
Drive pulley nut	M22	1	140 Nm (14.0 m·kg, 100 ft·lb)	Stake 
Drive pulley cover damper plate screw	M6	3	10 Nm (1.0 m·kg, 7.2 ft·lb)	
Drive pulley cover bolt	M6	4	10 Nm (1.0 m·kg, 7.2 ft·lb)	
Rectifier/regulator cover bolt	M6	6	10 Nm (1.0 m·kg, 7.2 ft·lb)	
Lead cover bolt	M6	2	10 Nm (1.0 m·kg, 7.2 ft·lb)	
Rectifier/regulator bolt	M6	2	10 Nm (1.0 m·kg, 7.2 ft·lb)	
Drive pulley cover plate bolt	M6	3	5 Nm (0.5 m·kg, 3.6 ft·lb)	
Wire harness guide bolt	M6	1	7 Nm (0.7 m·kg, 5.1 ft·lb)	
Throttle cable guide bolt (upper side)*1, 2	M6	1	7 Nm (0.7 m·kg, 5.1 ft·lb)	
Throttle cable guide bolt (lower side)*1, 2	M6	1	10 Nm (1.0 m·kg, 7.2 ft·lb)	
Throttle cable guide bolt*3	M6	1	7 Nm (0.7 m·kg, 5.1 ft·lb)	
Rear shock absorber locknut	M50	1	30 Nm (3.0 m·kg, 22 ft·lb)	
Windshield holder bracket assembly bolt*2	M8	4	30 Nm (3.0 m·kg, 22 ft·lb)	
Windshield holder nut*2	M8	4	23 Nm (2.3 m·kg, 17 ft·lb)	
Windshield bracket brace nut*2	M6	4	10 Nm (1.0 m·kg, 7.2 ft·lb)	
Windshield brace nut*2	M6	6	10 Nm (1.0 m·kg, 7.2 ft·lb)	
Windshield lock nut*2	M24	1	12 Nm (1.2 m·kg, 8.7 ft·lb)	
Windshield lock cover nut*2	M6	1	8 Nm (0.8 m·kg, 5.8 ft·lb)	
Backrest upper bracket and backrest lower bracket bolt*2	M8	4	23 Nm (2.3 m·kg, 17 ft·lb)	
Backrest pad and backrest upper bracket bolt*2	M6	1	10 Nm (1.0 m·kg, 7.2 ft·lb)	
Backrest pad and backrest upper bracket stay bolt*2	M6	2	10 Nm (1.0 m·kg, 7.2 ft·lb)	
Backrest lock nut*2	M24	1	12 Nm (1.2 m·kg, 8.7 ft·lb)	
Passenger footrest and sidebag bracket bolt (left and right)*2	M10	4	47 Nm (4.7 m·kg, 34 ft·lb)	

TIGHTENING TORQUES

Item	Thread size	Q'ty	Tightening torque	Remarks
Sidebag bracket bolt*2	M8	4	23 Nm (2.3 m·kg, 17 ft·lb)	
Sidebag bracket brace nut*2	M8	2	23 Nm (2.3 m·kg, 17 ft·lb)	

*1 For XV19S(C)/ XV19M(C)

*2 For XV19CTS(C)/ XV19CTM(C)

*3 For XV19CS(C)/ XV19C(C)

NOTE:

1. First, tighten the lower ring nut to approximately 52 Nm (5.2 m·kg, 37 ft·lb) with a torque wrench, then loosen the lower ring nut completely.
2. Retighten the lower ring nut to 18 Nm (1.8 m·kg, 13 ft·lb) with a torque wrench.

































LUBRICATION POINTS AND LUBRICANT TYPES

EAS20360







LUBRICATION POINTS AND LUBRICANT TYPES

EAS20370

ENGINE

Lubrication point	Lubricant
Oil seal lips	
O-rings	
Bearings	
Cylinder head nuts and washers	
Connecting rod small end and big end	
Crankshaft journals	
Piston surfaces	
Piston pins	
Connecting rod bolts	
Balancer idle gear inner surface and balancer idle gear shaft	
Left balancer driven gear inner surface	
Right balancer	
Gasket (left balancer driven gear housing)	
Flange bolts (left balancer drive gear and right balancer driven gear)	
Camshaft cam lobes and camshaft journals	
Flange bolt (camshaft gear)	
Valve push rod end balls	
Valve stems (intake and exhaust)	
Valve stem ends (intake and exhaust)	
Valve lifters	
Rocker arms	
Rocker arm shafts	
Camshaft (front and rear cylinders)	
Oil pump rotors (inner and outer) and oil pump housing	
Oil pump driven gear shaft	
Crankcase stud bolt ends	
Starter clutch idle gear shaft	
Starter clutch idle gear inner surface	
Starter clutch gear inner surface and outer surface	
Generator shaft journal	
Primary driven gear inner surface	
Clutch push rods and ball	
Clutch boss nut and washer	























LUBRICATION POINTS AND LUBRICANT TYPES

Lubrication point	Lubricant
Transmission gears (wheel and pinion) and collar	
Drive pulley nut and conical spring washer	
Middle drive gear nut and conical spring washer	
Shift forks and shift fork guide bars	
Shift drum	
Shift shaft and shift shaft oil seal	
Shift fork pawl	
Crankcase mating surface	Yamaha bond No.1215 (Three Bond No.1215®)
Stator coil lead grommet	Yamaha bond No.1215 (Three Bond No.1215®)
Crankshaft position sensor lead grommet	Yamaha bond No.1215 (Three Bond No.1215®)

LUBRICATION POINTS AND LUBRICANT TYPES

EAS20380

CHASSIS

Lubrication point	Lubricant
Steering bearings and upper bearing dust cover lip	
Lower bearing dust seal lip	
Lower bracket steering shaft*1	
Steering stem bolt*1	
Front wheel oil seal lips (left and right)	
Rear wheel oil seal lips	
Rear wheel drive hub oil seal lip	
Rear wheel drive hub mating surface	
Tube guide (throttle grip) inner surface and throttle cables	
Brake lever pivoting point and metal-to-metal moving parts	
Clutch lever pivoting point and metal-to-metal moving parts	
Brake pedal shaft pivoting point	
Shift pedal pivoting point	
Passenger footrest pivoting point and ball	
Sidestand pivoting point and metal-to-metal moving parts	
Dowel pins (rear fender stay)	
Pivot shaft	
Swingarm pivoting point, collar flange circumference, and oil seal inner surface	
Rear shock absorber bushings and O-rings	
Swingarm, relay arm bearings, and oil seal lips	
Connecting arm bushings and O-rings	
Rear wheel axle	
Clutch master cylinder push rod pin and contact surface	

*1 For XV19CS(C)/ XV19C(C)

LUBRICATION POINTS AND LUBRICANT TYPES

LUBRICATION SYSTEM CHART AND DIAGRAMS

EAS20390

LUBRICATION SYSTEM CHART AND DIAGRAMS

EAS20400

ENGINE OIL LUBRICATION CHART

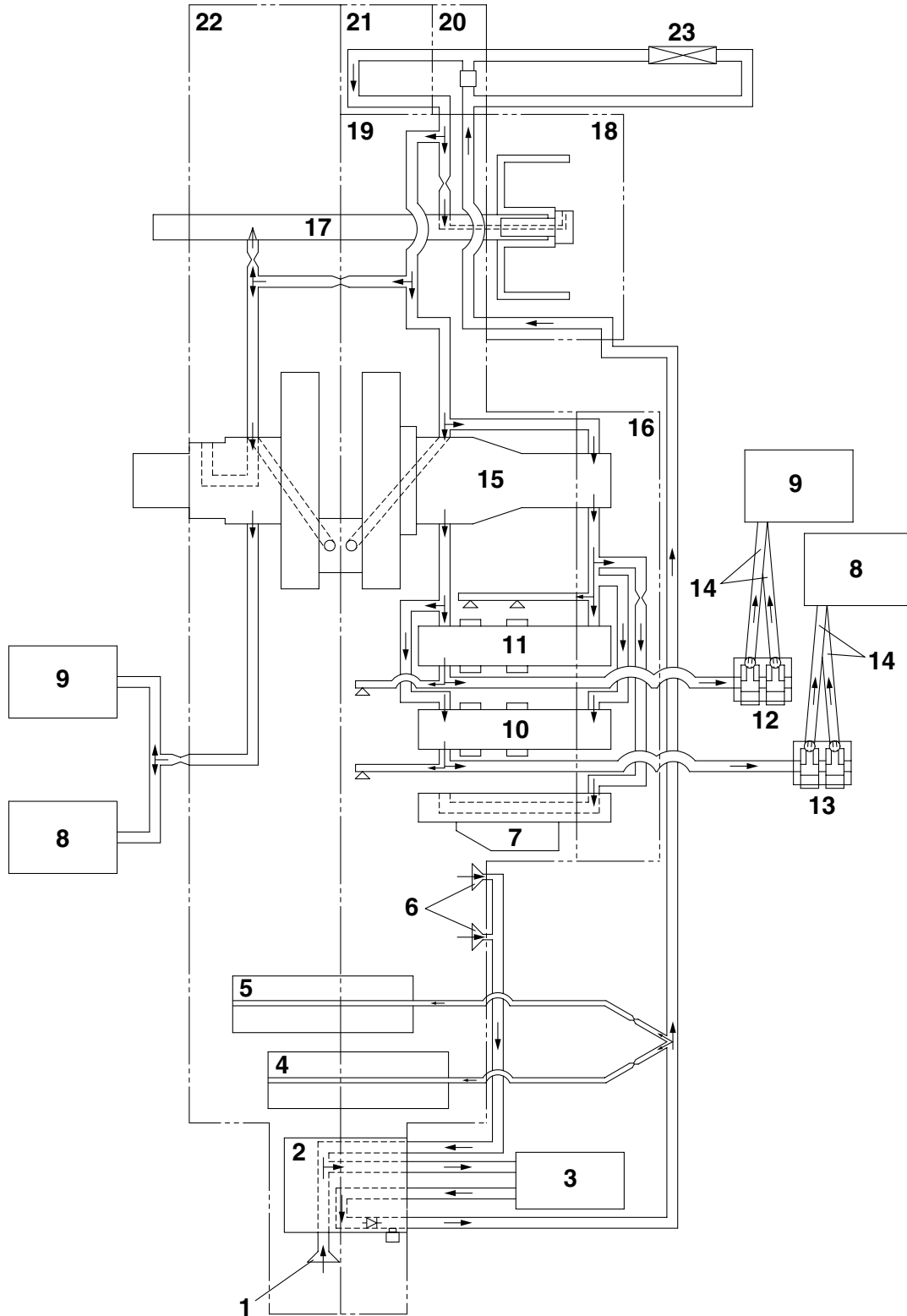

LUBRICATION SYSTEM CHART AND DIAGRAMS

1. Oil strainer (transfer gear case)
2. Oil pump
3. Oil tank
4. Drive axle
5. Main axle
6. Oil strainer (crankcase)
7. Balancer
8. Front cylinder head cover
9. Rear cylinder head cover
10. Rear cylinder camshaft
11. Front cylinder camshaft
12. Rear valve lifter case
13. Front valve lifter case
14. Push rod
15. Crankshaft
16. Camshaft sprocket cover
17. Generator shaft
18. Generator cover
19. Left crankcase
20. Oil filter cartridge bracket
21. Oil filter cartridge
22. Right crankcase
23. Oil cooler (for XV19S(C)/ XV19M(C)/
XV19CTS(C)/ XV19CTM(C))

LUBRICATION SYSTEM CHART AND DIAGRAMS

EAS20410

LUBRICATION DIAGRAMS

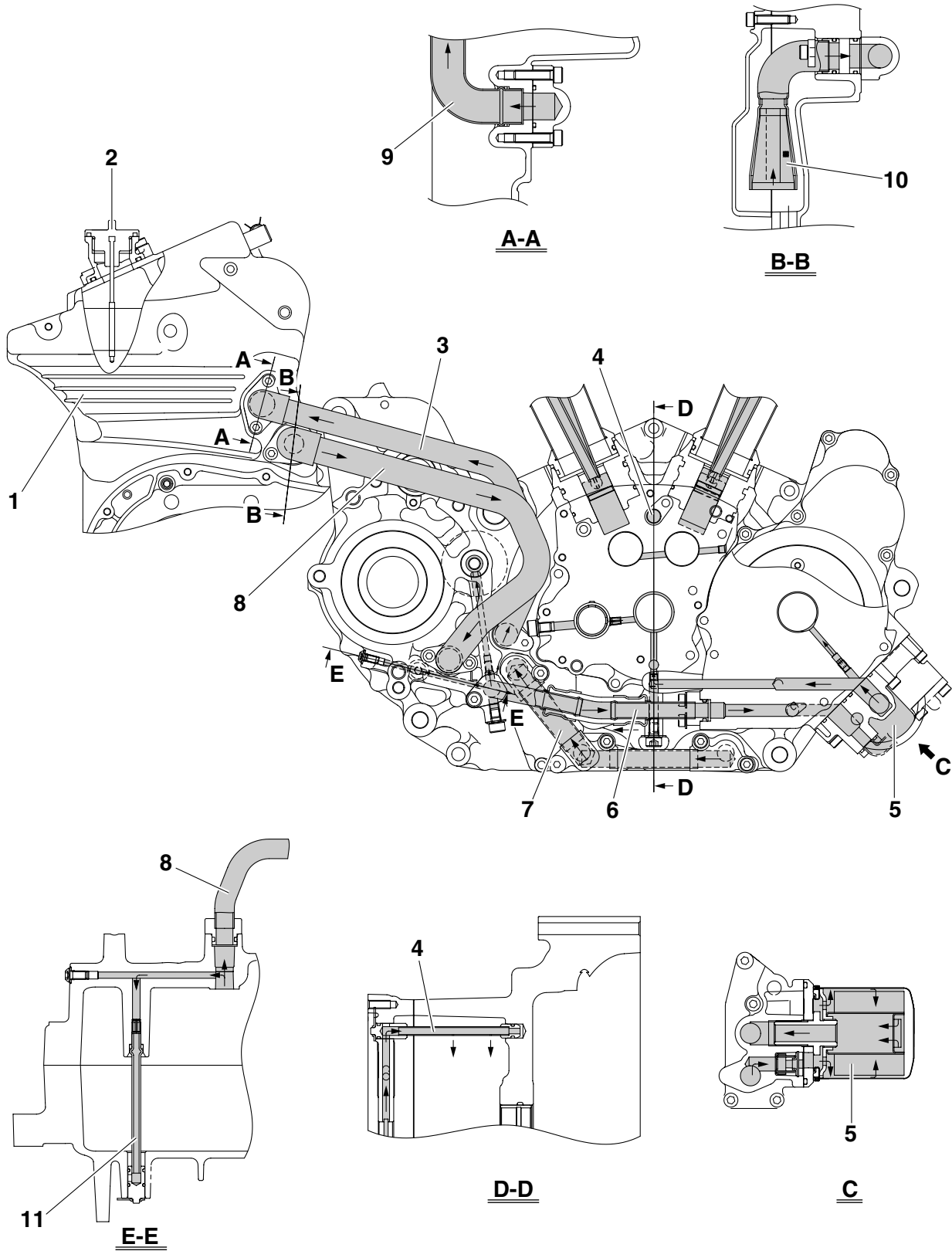

LUBRICATION SYSTEM CHART AND DIAGRAMS

1. Oil tank
2. Dipstick
3. Oil pipe 2
4. Oil delivery pipe 1
5. Oil filter cartridge
6. Oil delivery pipe 2
7. Oil pipe 3
8. Oil pipe 4
9. Oil pipe 5
10. Oil strainer (oil tank)
11. Oil delivery pipe 3

LUBRICATION SYSTEM CHART AND DIAGRAMS

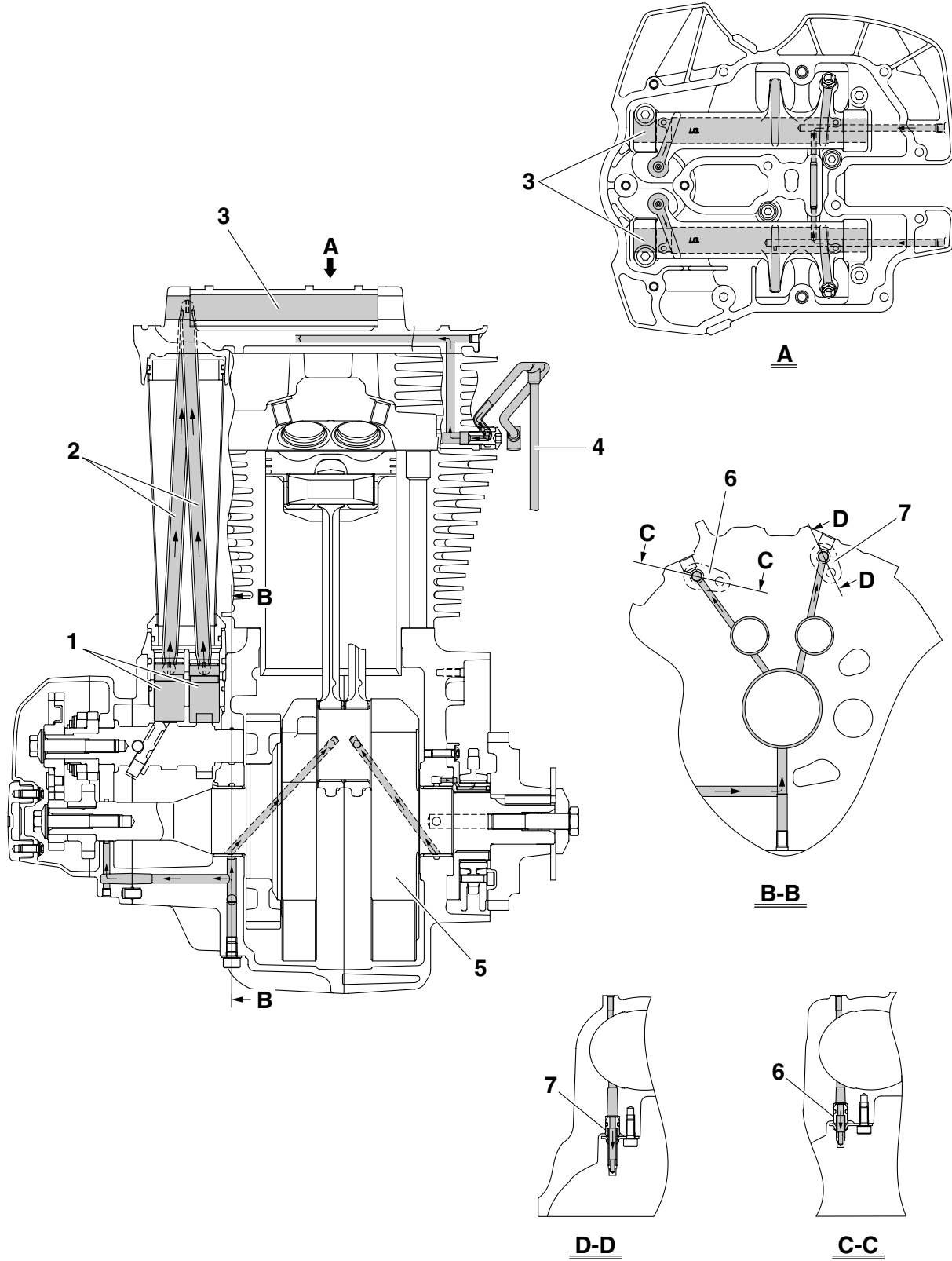

LUBRICATION SYSTEM CHART AND DIAGRAMS

1. Valve lifter
2. Push rod
3. Rocker arm shaft
4. Oil pipe 1
5. Crankshaft
6. Oil pipe ("F" mark)
7. Oil pipe ("R" mark)

LUBRICATION SYSTEM CHART AND DIAGRAMS

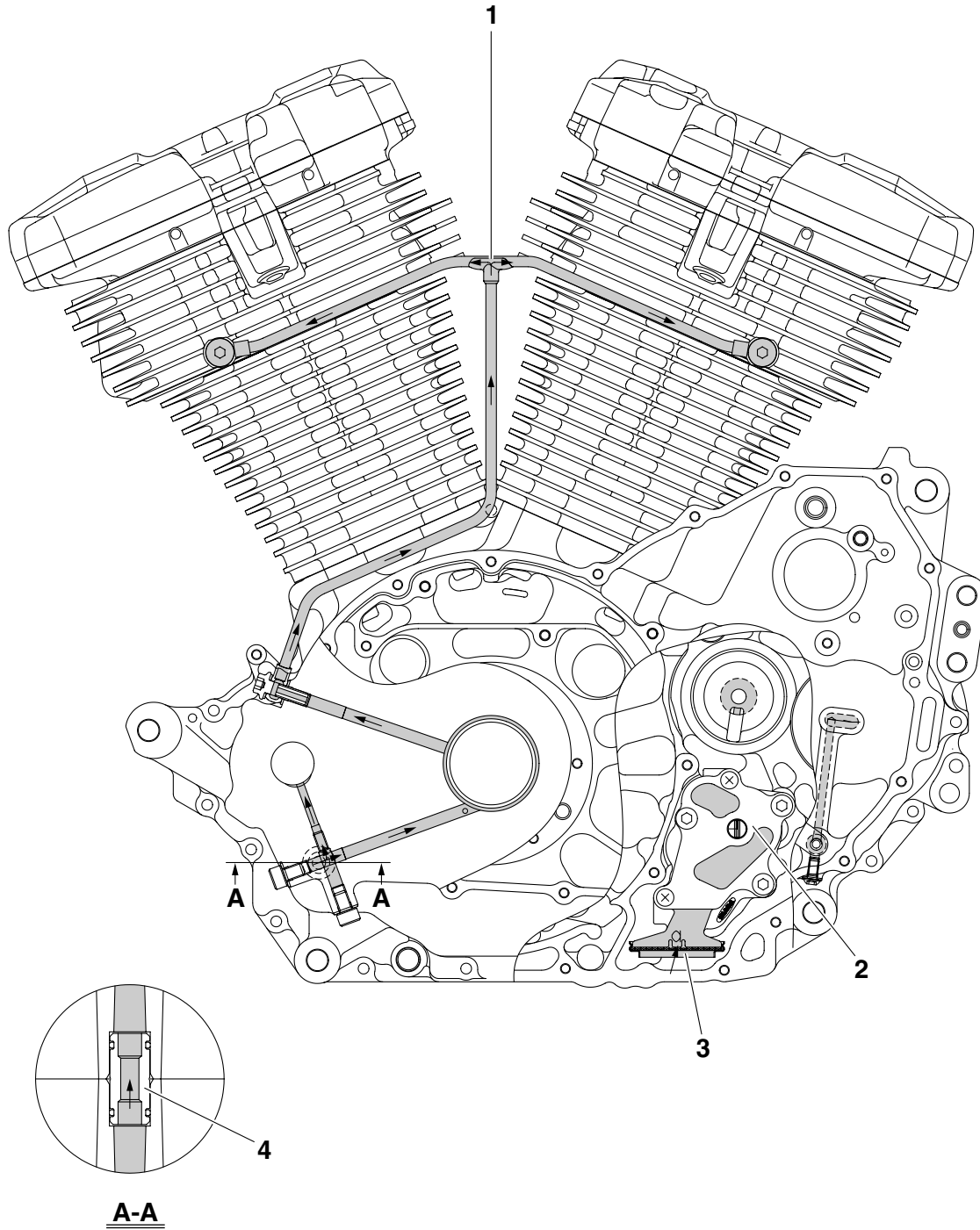

LUBRICATION SYSTEM CHART AND DIAGRAMS

1. Oil pipe 1
2. Oil pump
3. Oil strainer (crankcase)
4. Joint pipe

LUBRICATION SYSTEM CHART AND DIAGRAMS

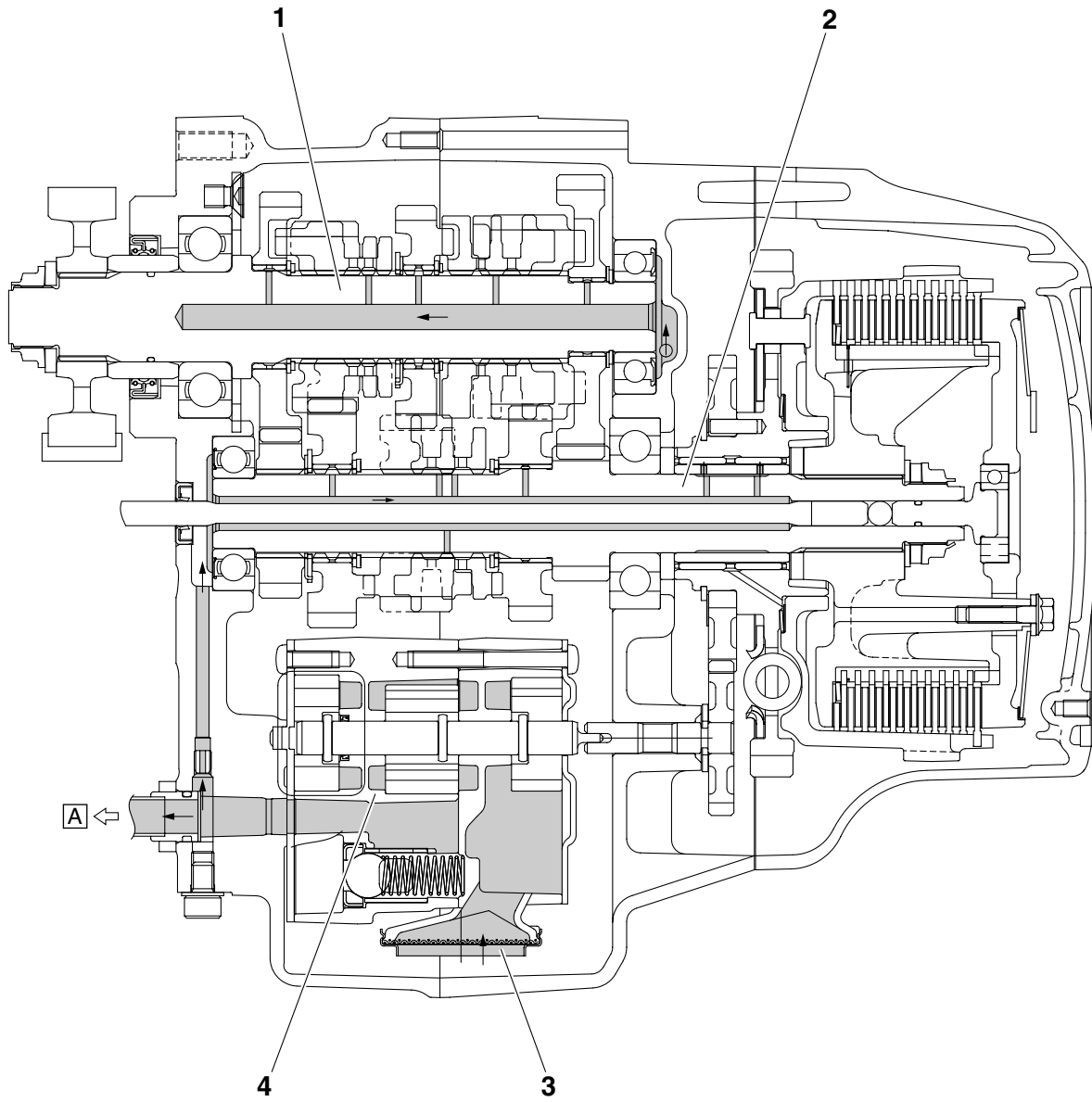

LUBRICATION SYSTEM CHART AND DIAGRAMS

1. Main axle
2. Drive axle
3. Oil strainer (crankcase)
4. Oil pump
- A. To the oil filter cartridge

LUBRICATION SYSTEM CHART AND DIAGRAMS

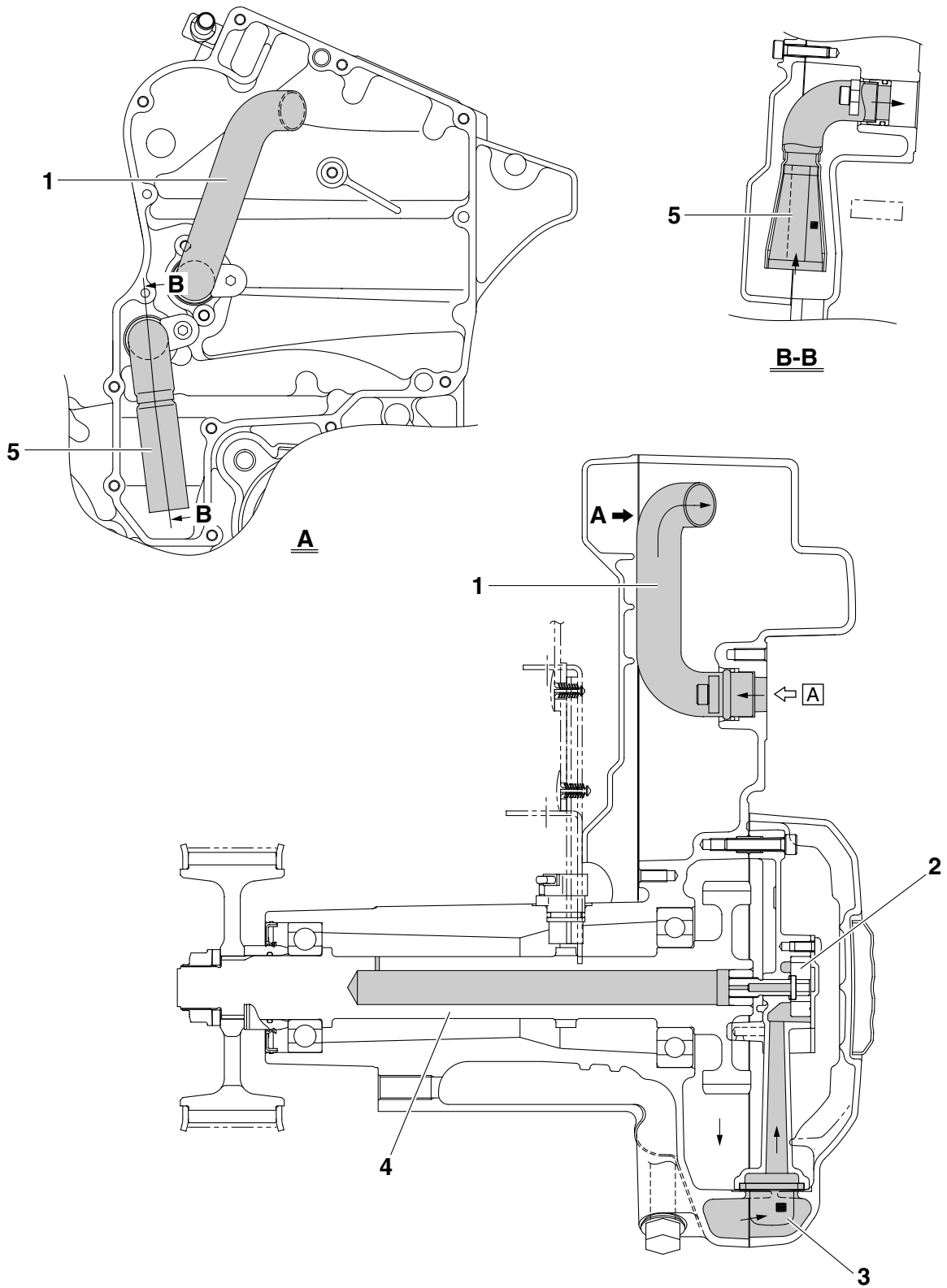

LUBRICATION SYSTEM CHART AND DIAGRAMS

1. Oil pipe 5
 2. Transfer gear oil pump
 3. Oil strainer (transfer gear case)
 4. Middle drive shaft
 5. Oil strainer (oil tank)
- A. From the oil pump

LUBRICATION SYSTEM CHART AND DIAGRAMS

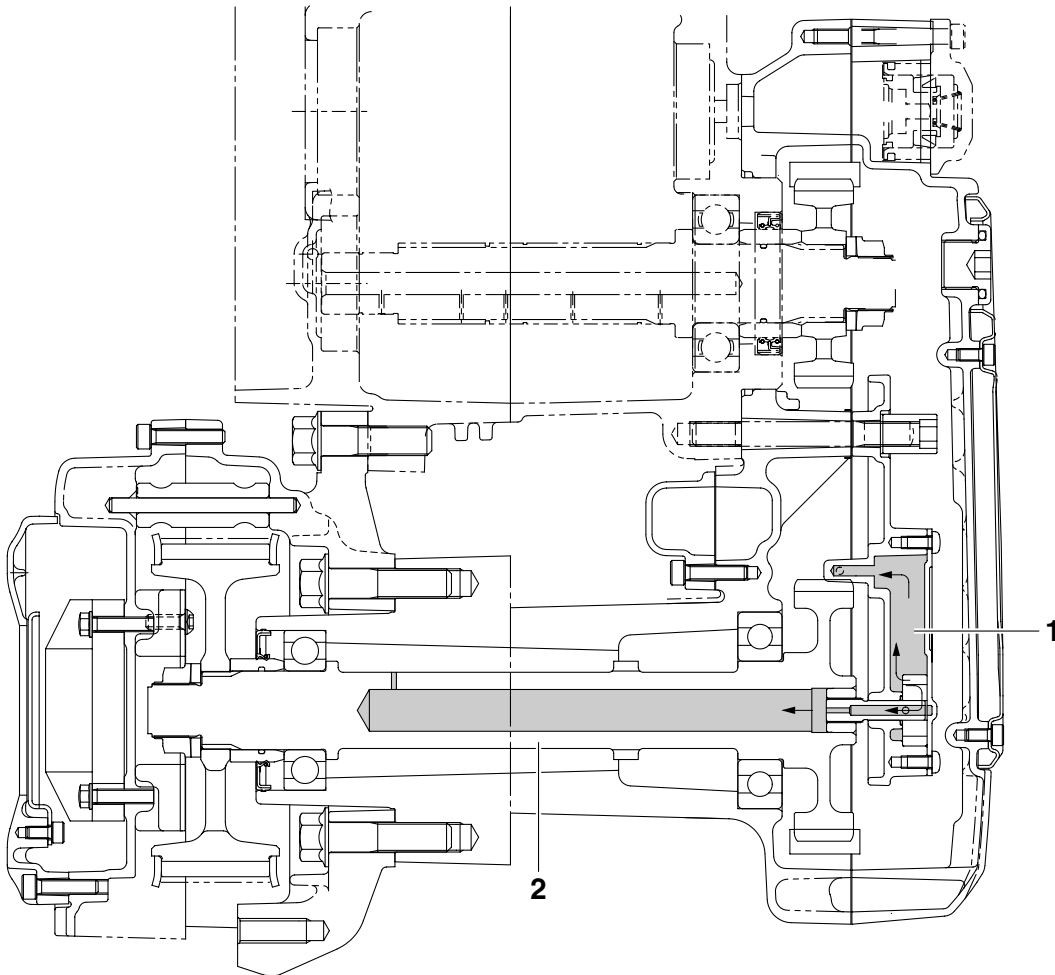

LUBRICATION SYSTEM CHART AND DIAGRAMS

1. Transfer gear oil pump
2. Middle driven shaft

CABLE ROUTING (for XV19S(C)/ XV19M(C)/ XV19CTS(C)/ XV19CTM(C))

EAS20430

CABLE ROUTING (for XV19S(C)/ XV19M(C)/ XV19CTS(C)/ XV19CTM(C))

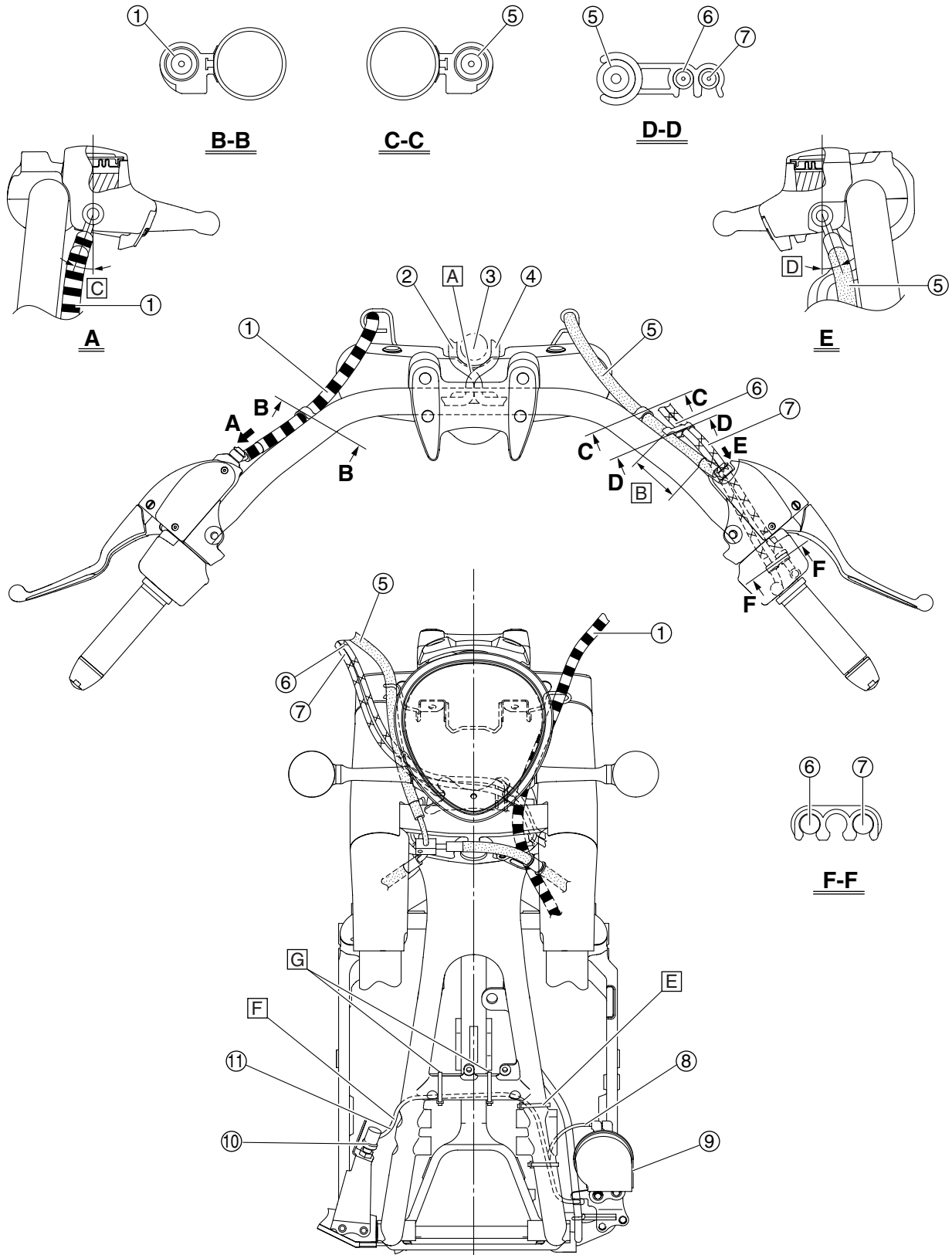

CABLE ROUTING (for XV19S(C)/ XV19M(C)/ XV19CTS(C)/ XV19CTM(C))

1. Clutch hose
2. Right handlebar switch lead
3. Main switch
4. Left handlebar switch lead
5. Front brake hose
6. Throttle cable (decelerator cable)
7. Throttle cable (accelerator cable)
8. Horn 1 lead
9. Horn 1
10. Rear brake light switch
11. Rear brake light switch lead
- A. Cross the left and right handlebar switch leads. Either lead can be routed on top.
- B. 70 mm (2.76 in)
- C. 5–25°
- D. 10–30°
- E. Fasten the rear brake light switch lead with the plastic locking tie. Face the end of the plastic locking tie inward, and then cut off the excess end of the tie.
- F. Make sure that there is no slack in the rear brake light switch lead in the area shown in the illustration.
- G. Fasten the rear brake light switch lead with the plastic locking tie. Face the end of the plastic locking tie downward, and then cut off the excess end of the tie.

CABLE ROUTING (for XV19S(C)/ XV19M(C)/ XV19CTS(C)/ XV19CTM(C))

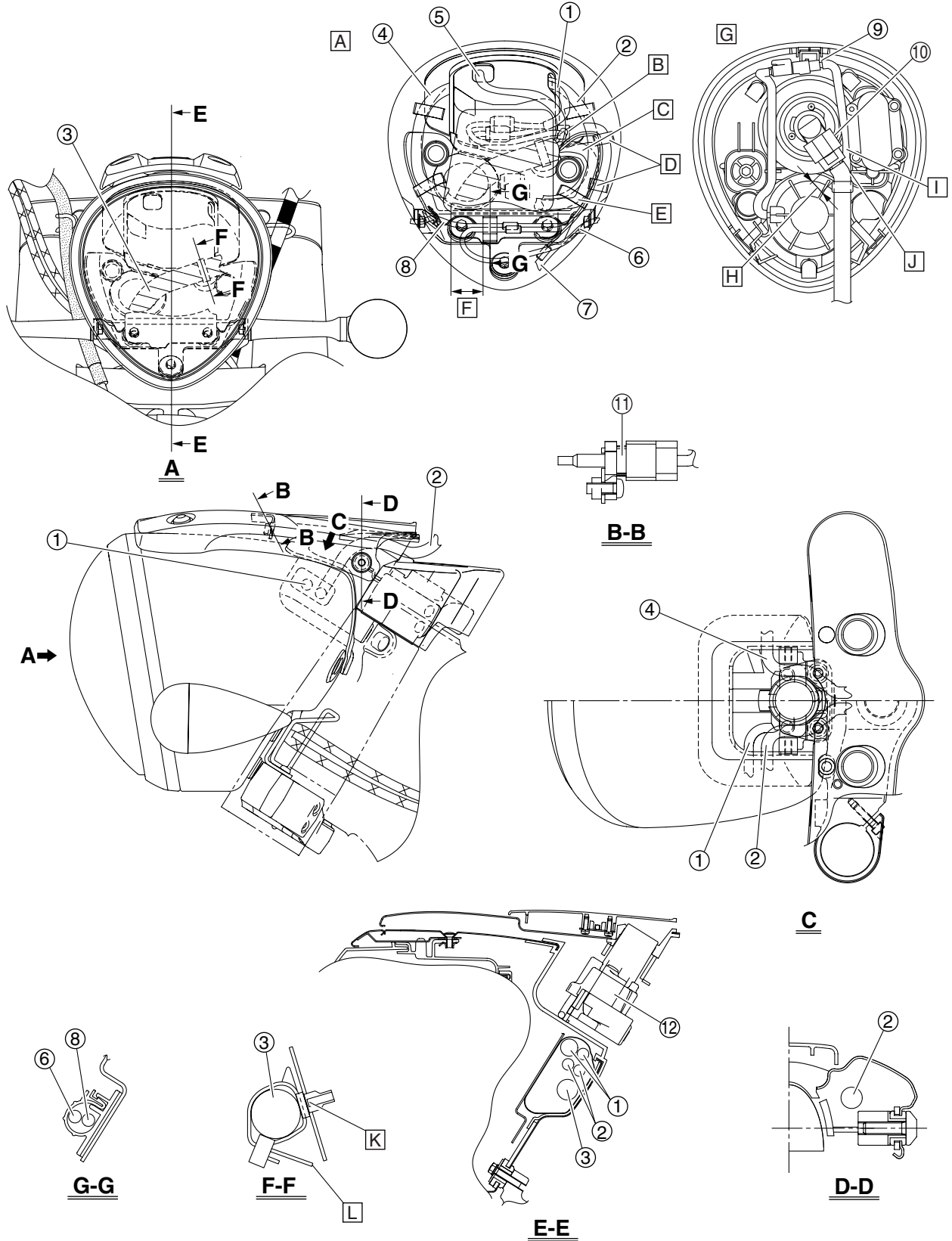

CABLE ROUTING (for XV19S(C)/ XV19M(C)/ XV19CTS(C)/ XV19CTM(C))

1. Main switch lead
2. Right handlebar switch lead
3. Wire harness
4. Left handlebar switch lead
5. Air temperature sensor lead
6. Front left turn signal/position light lead
7. Headlight lead
8. Front right turn signal/position light lead
9. Headlight coupler (high beam)
10. Headlight coupler (low beam)
11. Air temperature sensor
12. Main switch
 - A. View with headlight lens unit removed.
 - B. Place the joint coupler behind the leads.
 - C. Place the sections of the handlebar switch leads that are not covered by their protective sleeves in the rear of the headlight housing.
 - D. Fasten the headlight leads, front turn signal/position light leads, and accessory light lead with the holders along the side of the headlight housing.
 - E. Place the headlight leads, front turn signal/position light leads, and accessory light lead near the base of the holder.
 - F. 30 mm (1.18 in)
 - G. View from rear of headlight lens unit
 - H. Less than 20 mm (0.79 in). Fasten the headlight lead (low beam) with the holder, making sure to fasten the protective sleeve of the lead, not the lead itself.
 - I. Route the headlight lead (high beam) between the headlight coupler (low beam) and the stay.
 - J. Route the headlight lead (high beam) behind the headlight lead (low beam).
 - K. Secure the plastic band by inserting the projection on the band into the hole in the headlight housing.
 - L. Face the end of the plastic band downward.

CABLE ROUTING (for XV19S(C)/ XV19M(C)/ XV19CTS(C)/ XV19CTM(C))

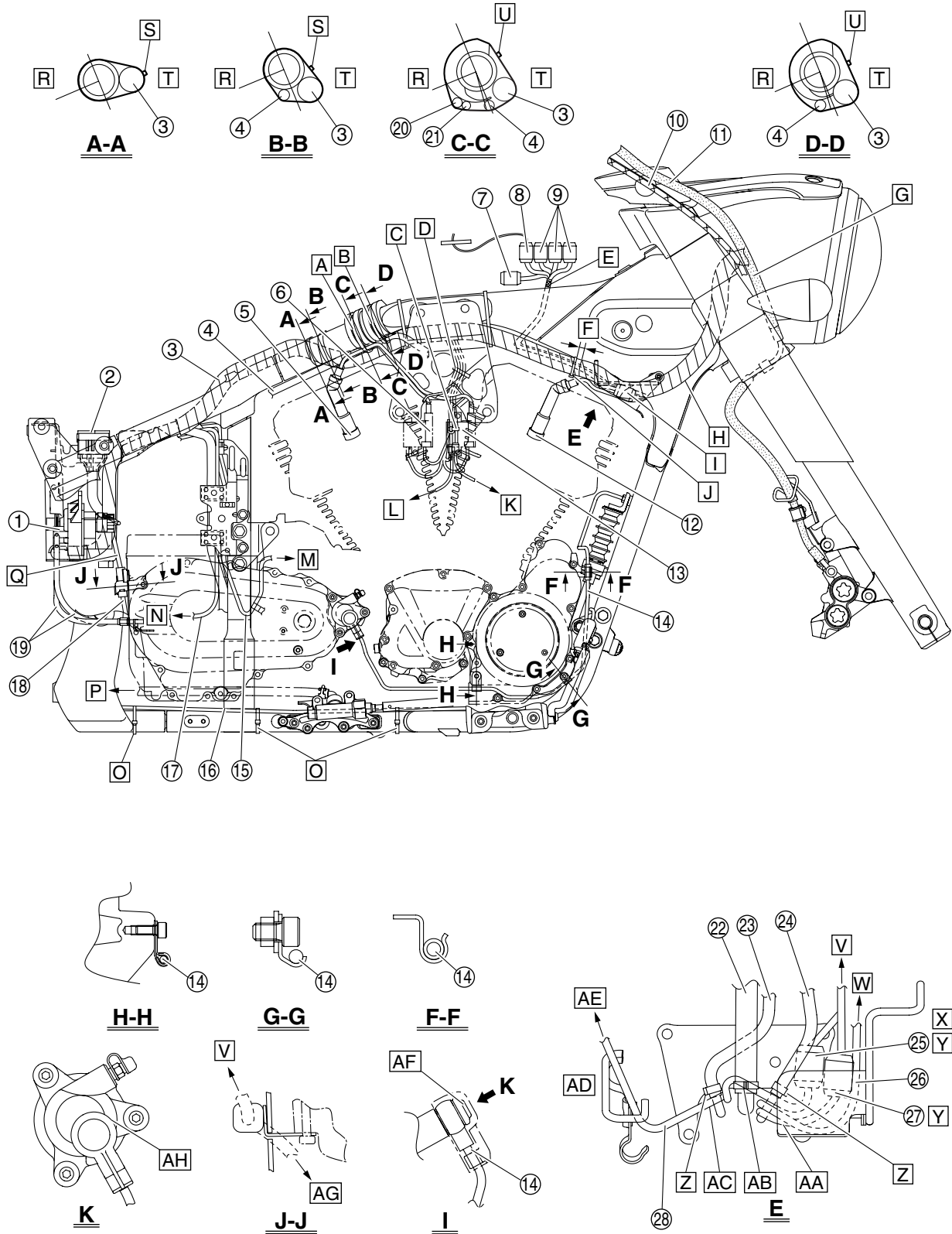

CABLE ROUTING (for XV19S(C)/ XV19M(C)/ XV19CTS(C)/ XV19CTM(C))

1. EXUP servo motor
2. Fuse box
3. Wire harness
4. Fuel outlet hose
5. Cylinder-#1 right spark plug cap
6. Cylinder-#1 right ignition coil
7. Cylinder-#2 intake air pressure sensor coupler
8. Fuel sender (fuel tank) coupler
9. Meter assembly coupler
10. Throttle cable
11. Front brake hose
12. Cylinder-#2 right spark plug cap
13. Cylinder-#1 left ignition coil
14. Clutch pipe
15. Neutral switch lead
16. Stator coil lead
17. Speed sensor lead
18. O₂ sensor lead
19. EXUP cable
20. Cylinder-#1 right spark plug lead
21. Cylinder-#1 left spark plug lead
22. ISC (idle speed control) unit inlet hose
23. Cylinder-#2 ISC (idle speed control) unit outlet hose
24. Cylinder-#1 ISC (idle speed control) unit outlet hose
25. Sub-wire harness 3 coupler
26. Cylinder-#2 right spark plug lead
27. Sub-wire harness 4 coupler
28. Cylinder-#2 left spark plug lead
- A. Fasten the cylinder-#1 left and right spark plug leads, fuel outlet hose, wire harness and the fuel tank damper with the plastic locking tie. Install the plastic locking tie in the rear slot of the fuel tank damper.
- B. Fasten the fuel outlet hose, wire harness, and fuel tank damper with the plastic locking tie. Install the plastic locking tie in the front slot of the fuel tank damper and make sure that the end of the damper is aligned with the edge of the flat section on the outside of the frame.
- C. Fasten the cylinder-#1 left and right ignition coil leads, engine temperature sensor lead, and throttle position sensor lead to the guide on the engine bracket (right upper side) with the plastic locking tie. Face the end of the plastic locking tie rearward, and then cut off the excess end of the tie.
- D. Fasten sub-wire harness 2 with the plastic locking tie.
- E. Align the positioning tape on the wire harness with the top of the frame.
- F. 0–15 mm (0–0.59 in)
- G. Route the throttle cables behind the front brake hose.
- H. Make sure that the wire harness is not twisted between the fuel tank and the headlight assembly.
- I. Position the cylinder-#2 left and right spark plug leads, sub-wire harness 2 coupler and sub-wire harness 4 coupler on top of the guide.
- J. Fasten the wire harness and the cylinder-#2 left and right spark plug leads with a plastic locking tie, making sure to install the tie just past the end of the protective tube of the wire harness. Face the end of the plastic locking tie inward, and then cut off the excess end of the tie.
- K. To the throttle position sensor
- L. To the fuel injector and engine temperature sensor
- M. To the neutral switch
- N. To the speed sensor
- O. Fasten the stator coil lead with the plastic locking ties. Face the end of each plastic locking tie outward, and then cut off the excess end of the tie.
- P. To the rear brake caliper
- Q. Install the O₂ sensor coupler completely onto the O₂ sensor bracket.
- R. Outside of the frame
- S. Position the buckle of the plastic locking tie to the inside of the frame. Face the end of the plastic locking tie upward, and then cut off the excess end of the tie.
- T. Inside of the frame
- U. Position the buckle of the plastic locking tie to the inside of the frame.
- V. To the wire harness
- W. To the cylinder-#2 right spark plug
- X. Right side
- Y. Position the sub-wire harness 3 coupler and the sub-wire harness 4 coupler between the cylinder-#2 right spark plug lead and the cylinder-#1 ISC unit outlet hose.
- Z. Face the ends of the hose clamp outward, angled 45° downward.
- AA. Route the cylinder-#2 right spark plug lead under the sub-wire harness 4.
- AB. Face the ends of the hose clamp downward.
- AC. Route the cylinder-#2 left spark plug lead under the cylinder-#2 ISC unit outlet hose.
- AD. Left side
- AE. To the cylinder-#2 left spark plug
- AF. Install the clutch pipe onto the clutch release cylinder, making sure that the pipe contacts the projection on the cylinder.
- AG. To the O₂ sensor
- AH. Align the cutout in the clutch pipe union bolt cap with the projection on the clutch release cylinder.

CABLE ROUTING (for XV19S(C)/ XV19M(C)/ XV19CTS(C)/ XV19CTM(C))

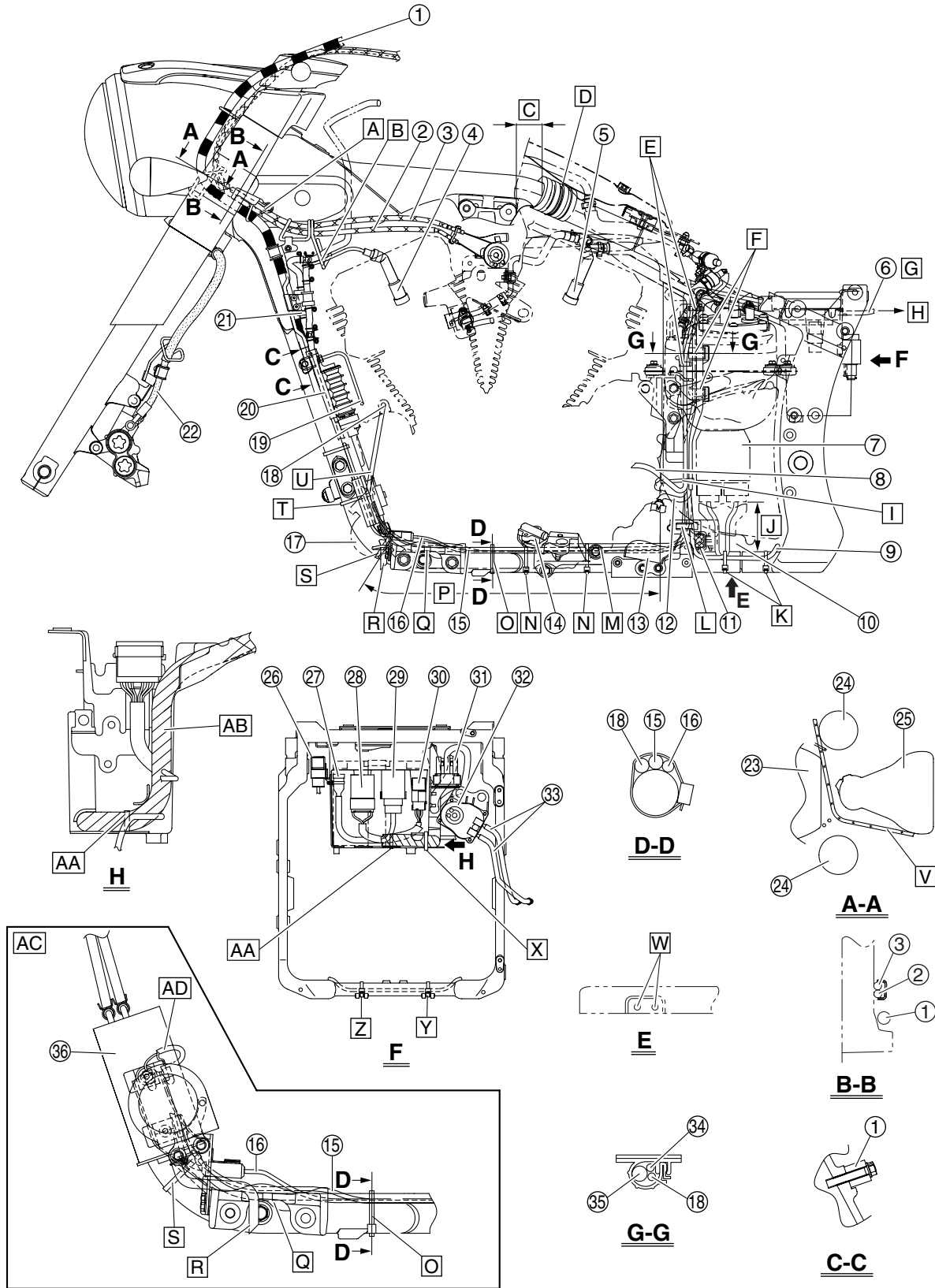

CABLE ROUTING (for XV19S(C)/ XV19M(C)/ XV19CTS(C)/ XV19CTM(C))

1. Clutch hose
2. Throttle cable (decelerator cable)
3. Throttle cable (accelerator cable)
4. Cylinder-#2 left spark plug cap
5. Cylinder-#1 left spark plug cap
6. Sub-wire harness 1
7. Rectifier/regulator
8. Crankshaft position sensor lead
9. Stator coil lead
10. Rectifier/regulator lead
11. Lean angle sensor
12. Horn 2 lead
13. Horn 2
14. Sidestand switch
15. Horn 1 lead
16. Rear brake light switch lead
17. Horn 1
18. Starter motor lead
19. Clutch pipe
20. Fuel tank breather/overflow hose
21. Rollover valve
22. Front brake hose
23. Headlight assembly
24. Front fork
25. Frame
26. Main fuse
27. Diode 1
28. Relay unit
29. Turn signal relay
30. Headlight relay
31. Starter relay
32. EXUP servo motor
33. EXUP cable
34. Speed sensor lead
35. Wire harness
36. Canister
- A. Route the throttle cables to the inside of the clutch hose.
- B. Pass the cylinder-#2 left spark plug lead through the guide.
- C. 30–40 mm (1.18–1.57 in)
- D. Position the buckle of the plastic locking tie to the inside of the frame.
- E. Fasten the crankshaft position sensor lead, neutral switch lead, and sidestand switch lead with the holders.
- F. Fasten the starter motor lead, speed sensor lead, and wire harness with the holders.
- G. Route sub-wire harness 1 to the inside of the frame.
- H. To the tail/brake light
- I. Fasten the starter motor lead, horn 1 lead, rear brake light switch lead, sidestand switch lead, and crankshaft position sensor lead with the plastic locking tie.
- J. Make sure that there is no slack in the stator coil lead and rectifier/regulator lead in the area shown in the illustration.
- K. Fasten the stator coil lead and rectifier/regulator lead with the plastic locking tie. Face the end of the plastic locking tie outward, and then cut off the excess end of the tie.
- L. Fasten the lean angle sensor lead, starter motor lead, horn 1 lead, rear brake light switch lead, and sidestand switch lead with the holder.
- M. Route the starter motor lead, horn 1 lead, rear brake light switch lead, and sidestand switch lead to the inside of the frame boss.
- N. Fasten the starter motor lead, horn 1 lead, rear brake light switch lead, and sidestand switch lead with the plastic locking tie. Face the end of the plastic locking tie outward, and then cut off the excess end of the tie.
- O. Fasten the starter motor lead, horn 1 lead, and rear brake light switch lead with the plastic locking tie, and then face the end of the tie outward. Be sure to install the plastic locking tie behind the frame cross member and to fasten the rear brake light switch lead at the white tape.
- P. Route the starter motor lead, horn 1 lead, and rear brake light switch lead along the frame in the area shown in the illustration, making sure not to cross the leads.
- Q. Align the positioning tape on the starter motor lead with the engine mounting bolt (front lower side).
- R. Pass the fuel tank breather/overflow hose through the horn 1 bracket, making sure to position the end of the hose as shown in the illustration.
- S. Fasten the starter motor lead, horn 1 lead, and rear brake light switch lead with the plastic locking tie, and then face the end of the tie inward.
- T. Fasten the horn 1 lead, rear brake light switch lead, and starter motor lead with the plastic locking tie. Face the end of the plastic locking tie inward, and then cut off the excess end of the tie.
- U. Route the horn 1 lead to the rear of the starter motor lead.
- V. Pass the throttle cables through the cable guides as shown in the illustration.
- W. Install the lead cover, making sure not to pinch the stator coil lead and rectifier/regulator lead.
- X. Pass the plastic locking tie through the hole in the battery box projection, and then fasten the wire harness with the tie.
- Y. Fasten the stator coil lead at the white tape with the plastic locking tie.
- Z. Fasten the stator coil lead with the plastic locking ties.
- AA. Pass the plastic locking tie through the hole in the battery box projection, and then fasten the wire harness with the tie.
- AB. Route the wire harness along the side of the fuse box/starter relay bracket.
- AC. For California only
- AD. Route the horn 1 lead to the rear of the canister.

CABLE ROUTING (for XV19S(C)/ XV19M(C)/ XV19CTS(C)/ XV19CTM(C))

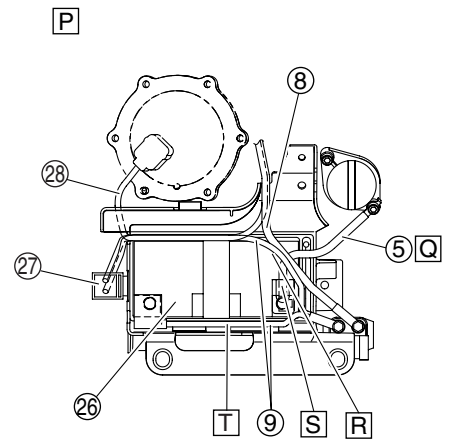
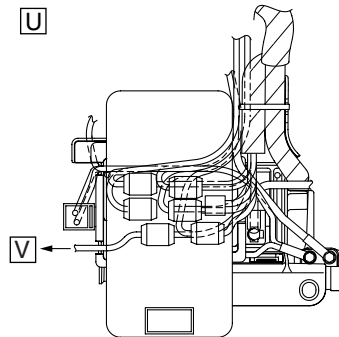
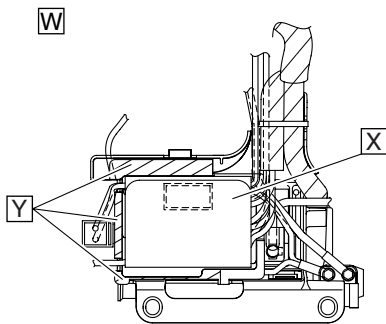
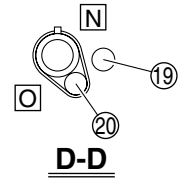
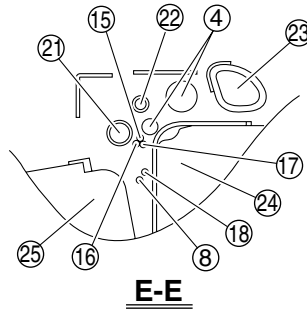
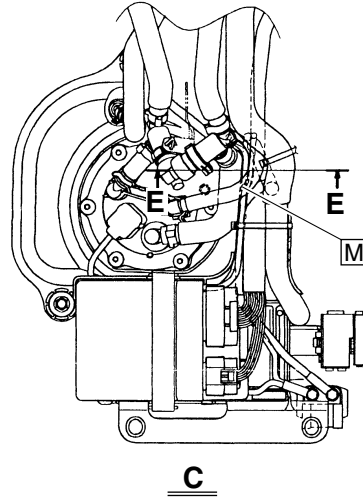
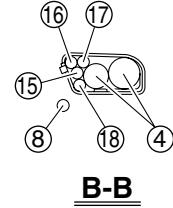
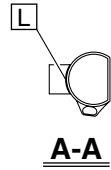
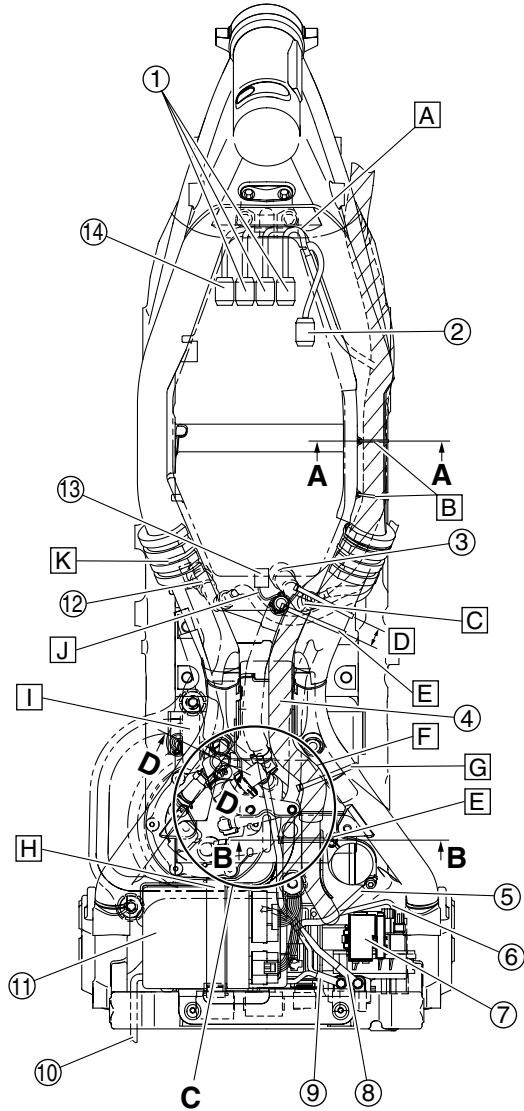

CABLE ROUTING (for XV19S(C)/ XV19M(C)/ XV19CTS(C)/ XV19CTM(C))

1. Meter assembly coupler
 2. Cylinder-#2 intake air pressure sensor coupler
 3. Cylinder-#1 right spark plug cap
 4. Wire harness
 5. Negative battery lead
 6. EXUP servo motor
 7. Fuse box
 8. Starter motor lead
 9. Positive battery lead
 10. Sub-wire harness 1
 11. ECU (electronic control unit)
 12. Cylinder-#1 left spark plug cap
 13. Cylinder-#1 intake air pressure sensor coupler
 14. Fuel sender (fuel tank) coupler
 15. Neutral switch lead
 16. Sidestand switch lead
 17. Crankshaft position sensor lead
 18. Speed sensor lead
 19. Fuel hose (fuel tank to fuel hose joint)
 20. Fuel return hose (fuel return pipe to sub-fuel tank)
 21. Air vent hose (fuel pump to fuel hose joint)
 22. Fuel outlet hose
 23. Frame
 24. Oil tank
 25. Sub-fuel tank
 26. Battery
 27. Main fuse
 28. Fuel pump lead
- A. Do not pinch the leads between the fuel tank bracket and the frame when installing the bracket.
 - B. Pass the plastic locking ties through the holes in the frame damper, and then fasten the wire harness and damper with the ties. Face the end of each plastic locking tie upward, and then cut off the excess end of the tie.
 - C. Align the white tape on the wire harness with the frame cross member.
 - D. 20 mm (0.79 in)
 - E. Fasten the wire harness with the plastic locking tie. Face the end of the plastic locking tie upward, and then cut off the excess end of the tie.
 - F. Route the wire harness along the frame.
 - G. Fasten the wire harness with the plastic locking tie, making sure to align the tie with the line on the rubber damper. Face the end of the plastic locking tie upward, and then cut off the excess end of the tie.
 - H. Connect the ECU couplers, and then fasten the ECU with the band.
 - I. Fasten the fuel return hose (fuel return pipe to sub-fuel tank) with the plastic locking tie. Face the end of the plastic locking tie inward, and then cut off the excess end of the tie.
 - J. Route the cylinder-#1 intake air pressure sensor lead so that it does not protrude past the top of the frame.
 - K. Fasten the fuel tank damper with the plastic locking tie. Install the plastic locking tie in the middle slot of the fuel tank damper.
 - L. Fasten the air filter case damper with the plastic locking tie so that the rubber part of the damper contacts the frame. Be sure to pass the plastic locking tie between the air filter case damper and the frame.
 - M. Route the crankshaft position sensor lead, sidestand switch lead, neutral switch lead, starter motor lead, and speed sensor lead under the fuel outlet hose.
 - N. Inside of frame
 - O. Outside of frame
 - P. View with tray removed
 - Q. Route the negative battery lead under the starter motor lead and battery positive lead.
 - R. Route the positive battery lead (main fuse to starter relay) over the tray.
 - S. Route the negative battery lead towards the front of the vehicle.
 - T. Route the positive battery lead (battery to starter relay) under the tray.
 - U. View with tray installed
 - V. To the tail/brake light
 - W. View with ECU removed
 - X. Wrap the protective covering around the couplers (crankshaft position sensor coupler, auxiliary DC jack coupler, neutral switch coupler, sub-wire harness 1 coupler, speed sensor coupler, and sidestand switch coupler) and the wire harness.
 - Y. When installing the ECU, be sure not to pinch the leads in the areas shown in the illustration with oblique lines.

CABLE ROUTING (for XV19S(C)/ XV19M(C)/ XV19CTS(C)/ XV19CTM(C))

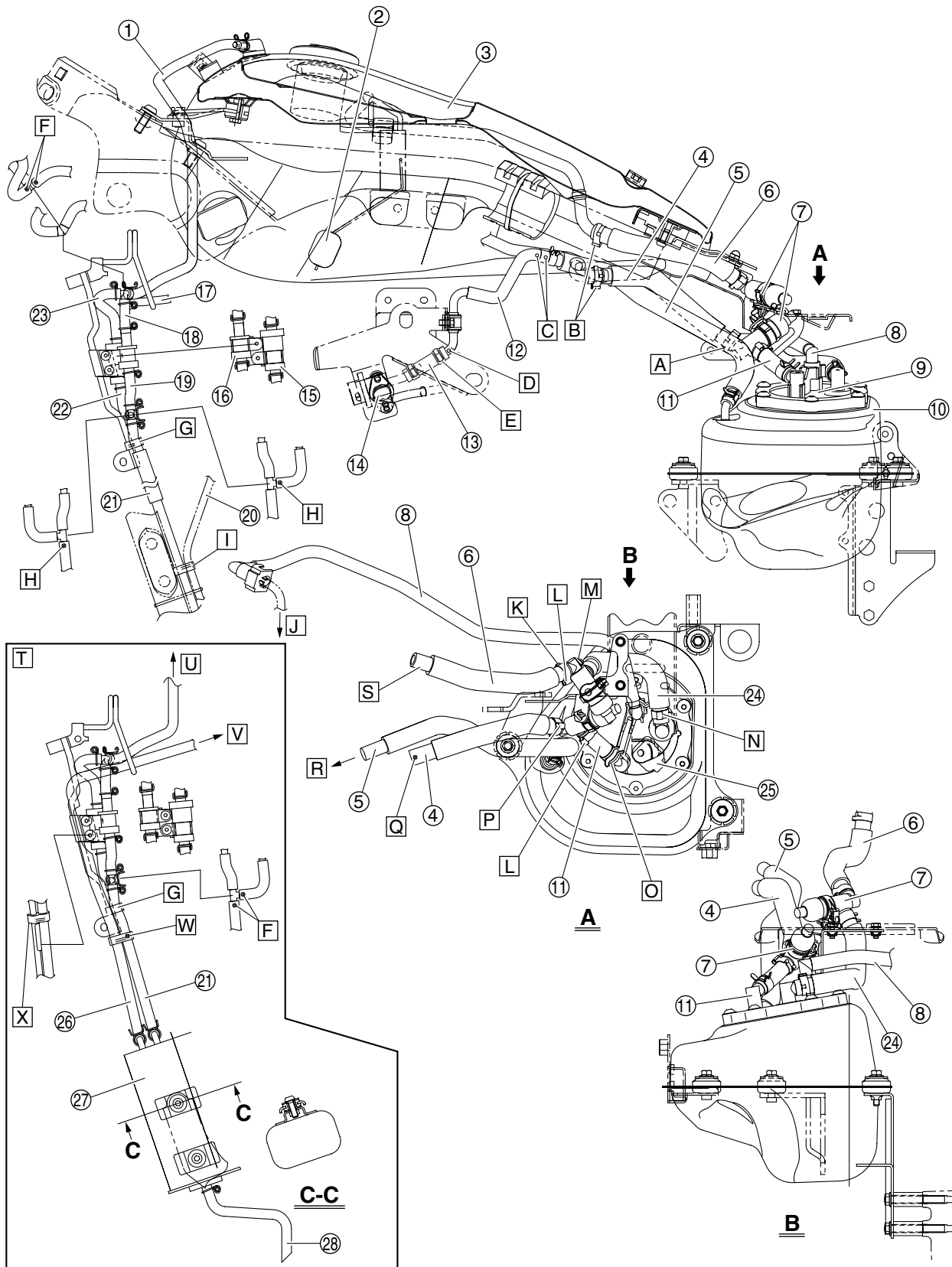

CABLE ROUTING (for XV19S(C)/ XV19M(C)/ XV19CTS(C)/ XV19CTM(C))

1. Fuel tank breather hose
2. Fuel sender (fuel tank)
3. Fuel tank
4. Fuel hose (fuel tank to fuel hose joint)
5. Fuel return hose (fuel return pipe to sub-fuel tank)
6. Air vent hose (fuel hose joint to fuel tank)
7. Fuel hose joint
8. Fuel outlet hose
9. Fuel pump
10. Sub-fuel tank
11. Fuel hose (fuel hose joint to fuel pump)
12. Fuel return pipe
13. Fuel return hose (pressure regulator to fuel return pipe)
14. Pressure regulator
15. Rollover valve 1
16. Rollover valve 2
17. Cylinder-#2 left spark plug lead
18. Rollover valve hose 1
19. Rollover valve hose 2
20. Starter motor lead
21. Fuel tank breather/overflow hose
22. Rollover valve hose 4
23. Rollover valve hose 3
24. Air vent hose (fuel pump to fuel hose joint)
25. Fuel pump coupler
26. Canister purge hose (for California only)
27. Canister (for California only)
28. Canister breather hose (for California only)
- A. Align the blue paint mark on the fuel hose (fuel hose joint to fuel tank) with the round indentation on the bend in the fuel hose joint.
- B. Face the fastener of the clamp downward, making sure that the projections on the clamp are positioned as shown in the illustration.
- C. Align the white paint mark on the end of the fuel return hose (fuel return pipe to sub-fuel tank) with the white paint mark on the fuel return pipe.
- D. White paint mark
- E. Align the ends of the hose clamp with the white paint mark on the fuel return hose.
- F. Align the paint marks on the hoses with the hose joint as shown in the illustration.
- G. Fasten the fuel tank breather/overflow hose to the throttle cable guide with the holder.
- H. Align the paint mark on the hose with the hose joint as shown in the illustration.
- I. Fasten the fuel tank breather/overflow hose and starter motor lead with the holder.
- J. To the fuel injector
- K. Align the yellow paint mark on the air vent hose (fuel hose joint to fuel tank) with the round indentation on the bend in the fuel hose joint.
- L. Face the fastener of the clamp to the left.
- M. Face the ends of the hose clamp forward.
- N. Install the air vent hose (fuel pump to fuel hose joint) with its white paint mark facing upward.
- O. Face the ends of the hose clamp upward.
- P. Face the fastener of the clamp upward, making sure that the projections on the clamp are positioned as shown in the illustration.
- Q. Install the fuel hose (fuel tank to fuel hose joint) with its white paint mark facing downward.
- R. To the pressure regulator
- S. Install the air vent hose (fuel hose joint to fuel tank) with its white paint mark facing downward.
- T. For California only
- U. To the fuel tank
- V. To the intake manifold assembly
- W. Fasten the canister purge hose and fuel tank breather/overflow hose with the holder, making sure to align the paint mark on the breather/overflow hose with the holder.
- X. Fasten the canister purge hose and throttle cable guide with the holder.

CABLE ROUTING (for XV19S(C)/ XV19M(C)/ XV19CTS(C)/ XV19CTM(C))

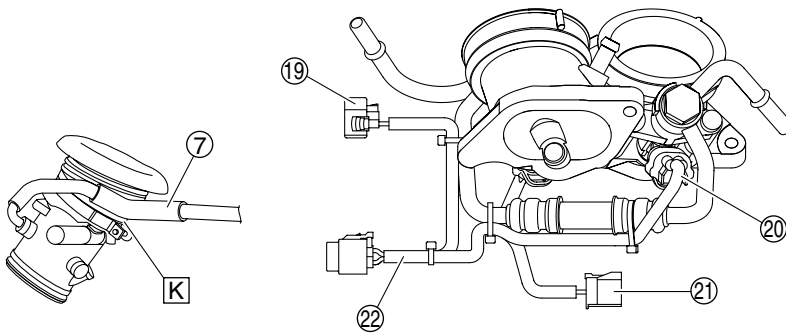
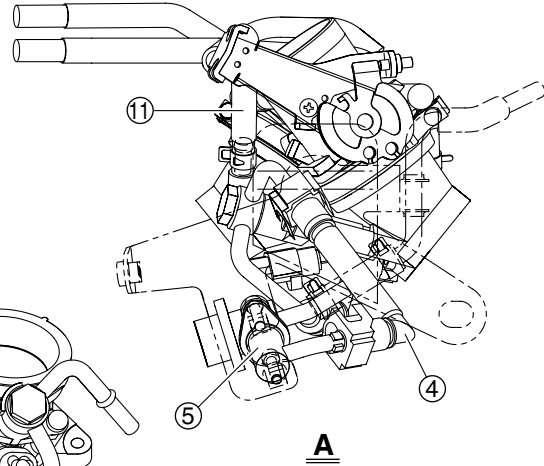
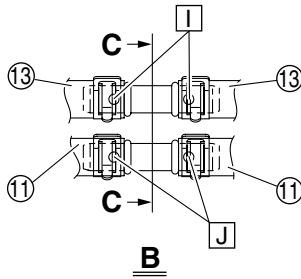
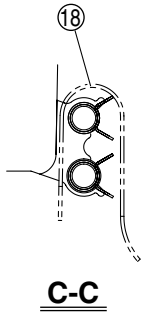
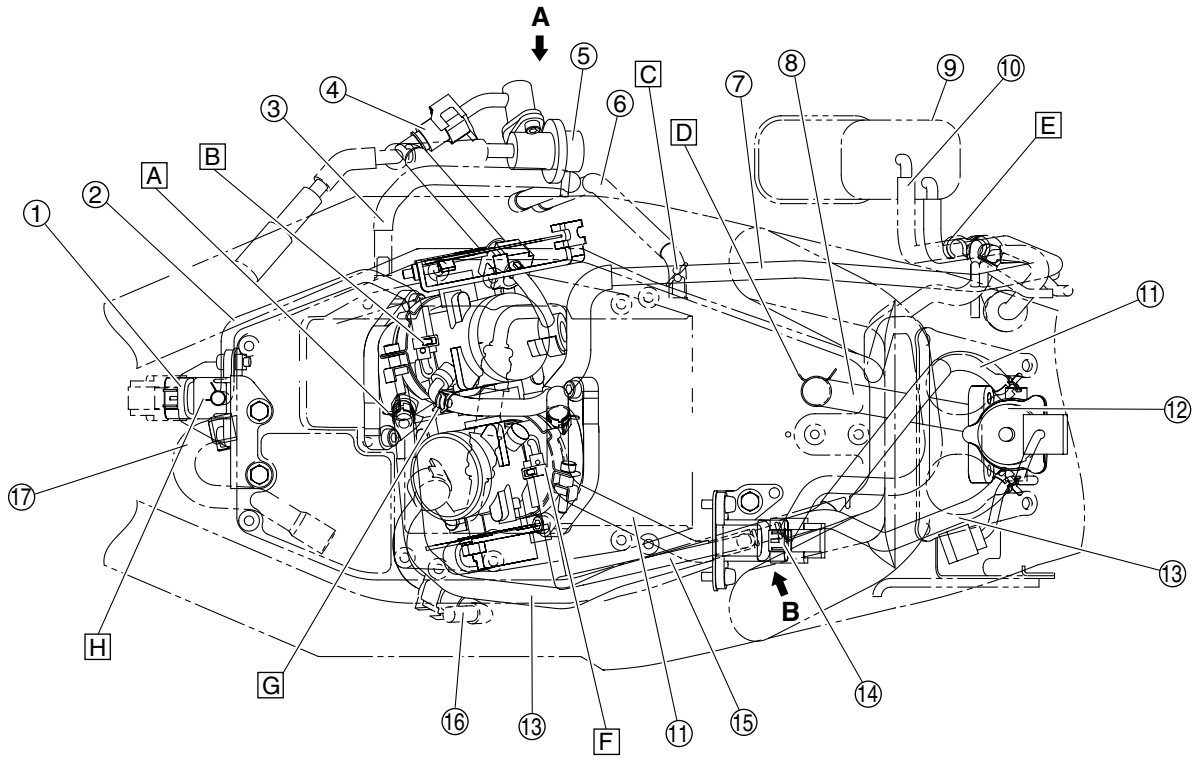

CABLE ROUTING (for XV19S(C)/ XV19M(C)/ XV19CTS(C)/ XV19CTM(C))

1. Cylinder-#1 intake air pressure sensor
2. Cylinder-#1 intake air pressure sensor hose
3. Air filter case breather hose 1
4. Fuel hose (intake manifold assembly to pressure regulator)
5. Pressure regulator
6. Air filter case breather hose 2
7. Canister purge hose (for California only)
8. ISC (idle speed control) unit inlet hose
9. Canister (for California only)
10. Fuel tank breather/overflow hose (for California only)
11. Cylinder-#2 ISC (idle speed control) unit outlet hose
12. ISC (idle speed control) unit
13. Cylinder-#1 ISC (idle speed control) unit outlet hose
14. Cylinder-#2 intake air pressure sensor
15. Cylinder-#1 intake air pressure sensor hose
16. Fuel outlet hose
17. Cylinder head breather hose
18. Hose joint cover
19. Throttle position sensor
20. Cylinder-#1 injector coupler
21. Engine temperature sensor coupler
22. Sub-wire harness 2
 - A. Face the ends of the hose clamp to the left, angled 45° rearward.
 - B. Install the cylinder-#1 intake air pressure sensor hose onto the throttle body pipe up to the bend in the pipe, making sure to face the white paint mark on the hose upward. Face the ends of the hose clamp forward.
 - C. Fasten the canister purge hose and the air filter case breather hose 2 with the hose clamp, making sure to face the ends of the clamp upward (for California only).
 - D. Face the ends of the hose clamp to the left.
 - E. Fasten the canister purge hose and fuel tank breather/overflow hose with the holder 70 mm (2.76 in) from the hose joints on the canister (for California only).
 - F. Install the cylinder-#2 intake air pressure sensor hose onto the throttle body pipe up to the bend in the pipe, making sure to face the white paint mark on the hose upward. Face the ends of the hose clamp rearward.
 - G. Install the canister purge hose onto the throttle body pipe up to the bend in the pipe, making sure to face the white paint mark on the hose upward (for California only).
 - H. Face the ends of the hose clamp rearward, angled to the left.
 - I. Align the white paint marks.
 - J. Align the yellow paint marks.
 - K. Route the canister purge hose over the air filter case joint clamp screw.

CABLE ROUTING (for XV19S(C)/ XV19M(C)/ XV19CTS(C)/ XV19CTM(C))

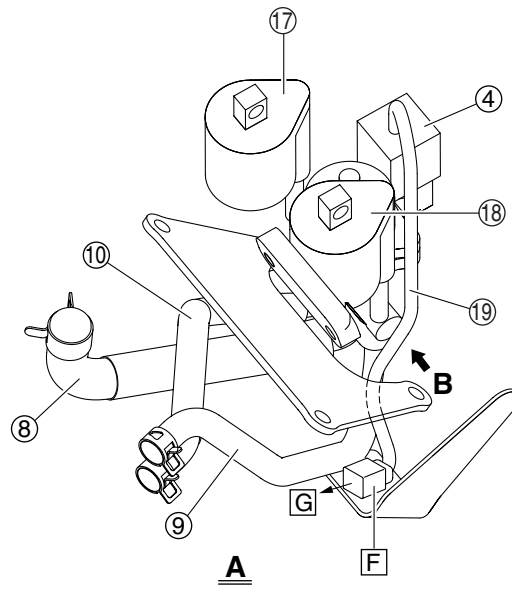
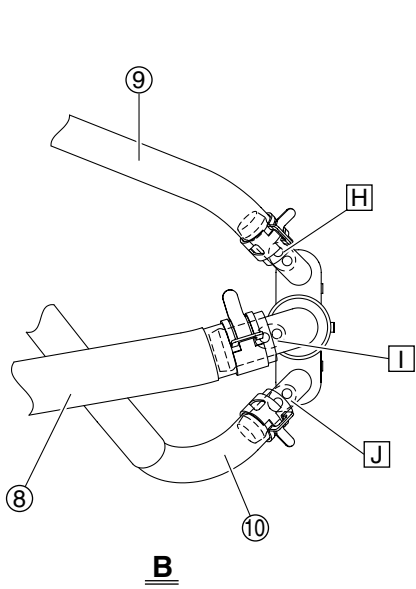
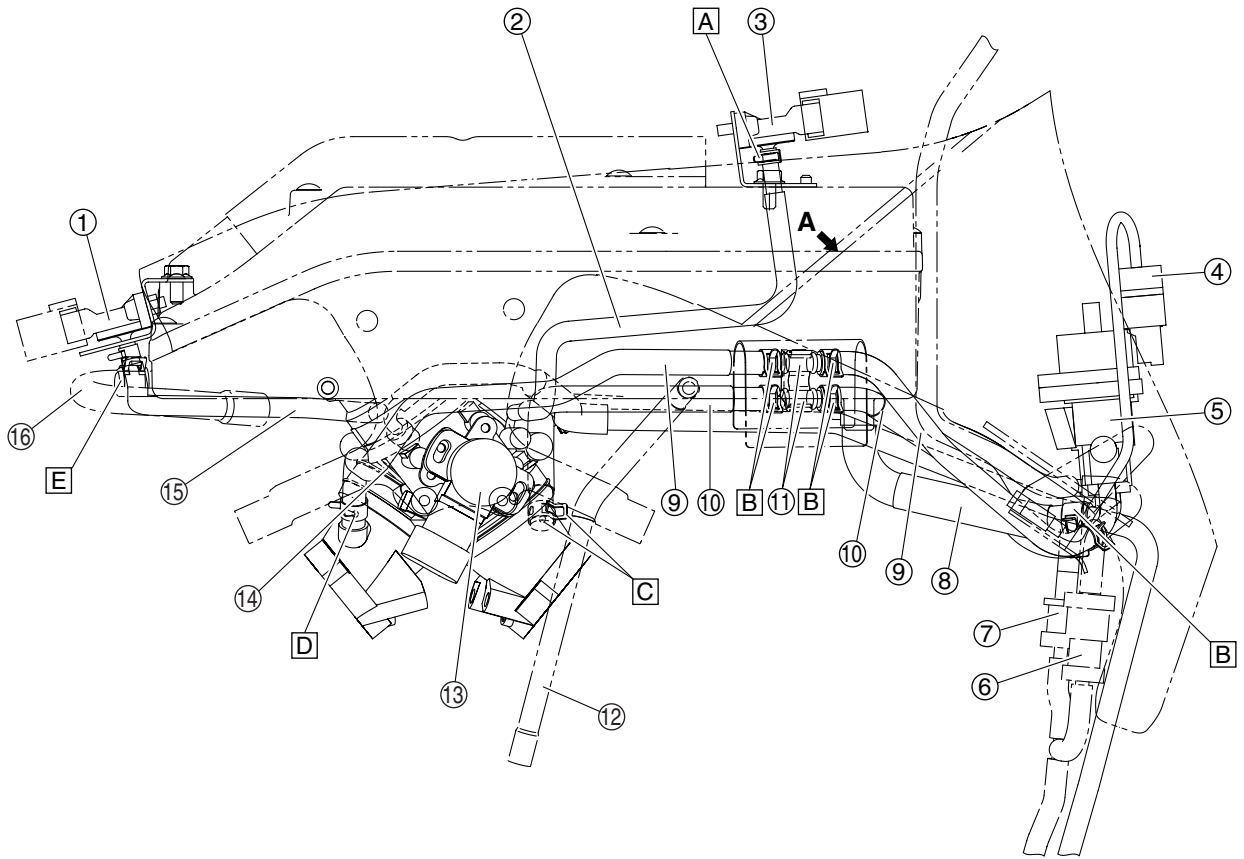

CABLE ROUTING (for XV19S(C)/ XV19M(C)/ XV19CTS(C)/ XV19CTM(C))

1. Cylinder-#1 intake air pressure sensor
 2. Cylinder-#2 intake air pressure sensor hose
 3. Cylinder-#2 intake air pressure sensor
 4. ISC (idle speed control) unit coupler
 5. ISC (idle speed control) unit
 6. Rollover valve 1
 7. Rollover valve 2
 8. ISC (idle speed control) unit inlet hose
 9. Cylinder-#1 ISC (idle speed control) unit outlet hose
 10. Cylinder-#2 ISC (idle speed control) unit outlet hose
 11. Hose joint
 12. Air filter case breather hose 2
 13. Throttle position sensor
 14. Throttle body assembly
 15. Cylinder-#1 intake air pressure sensor hose
 16. Cylinder head breather hose
 17. Cylinder-#2 left ignition coil
 18. Cylinder-#2 right ignition coil
 19. Sub-wire harness 4
- A. Face the ends of the hose clamp inward.
 - B. Face the ends of the hose clamps outward.
 - C. Install the cylinder-#2 ISC (idle speed control) unit outlet hose (hose joint to intake manifold assembly) completely onto the intake manifold, making sure to face the green paint mark on the hose to the left. Face the ends of the hose clamp outward, angled 45° forward.
 - D. Install the cylinder-#1 ISC (idle speed control) unit outlet hose (hose joint to intake manifold assembly) completely onto the intake manifold, making sure to face the blue paint mark on the hose to the left.
 - E. Face the ends of the hose clamp upward.
 - F. Position the sub-wire harness 4 coupler on top of the guide.
 - G. To the wire harness
 - H. Install the cylinder-#1 ISC (idle speed control) unit outlet hose onto the ISC unit pipe, making sure to align the blue paint mark on the hose with the blue paint mark on the pipe.
 - I. Install the ISC (idle speed control) unit inlet hose onto the ISC unit pipe, making sure to align the white paint mark on the hose with the white paint mark on the pipe.
 - J. Install the cylinder-#2 ISC (idle speed control) unit outlet hose onto the ISC unit pipe, making sure to align the green paint mark on the hose with the green paint mark on the pipe.

CABLE ROUTING (for XV19CS(C)/ XV19C(C))

EAS1D77001

CABLE ROUTING (for XV19CS(C)/ XV19C(C))

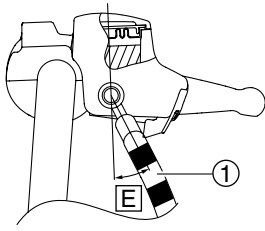

A

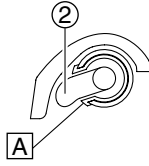

B-B

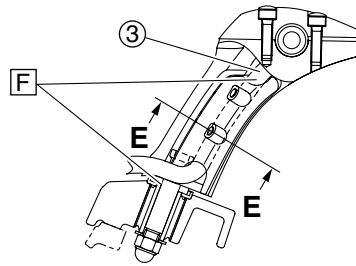

C-C

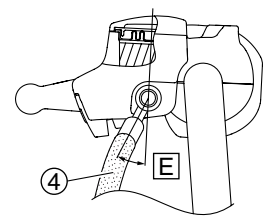

D

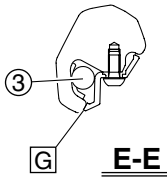

E-E

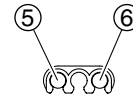
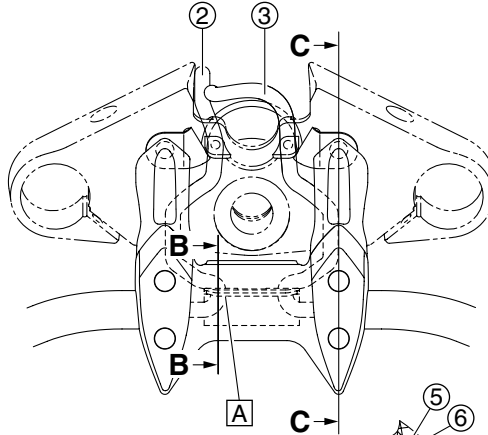

F-F

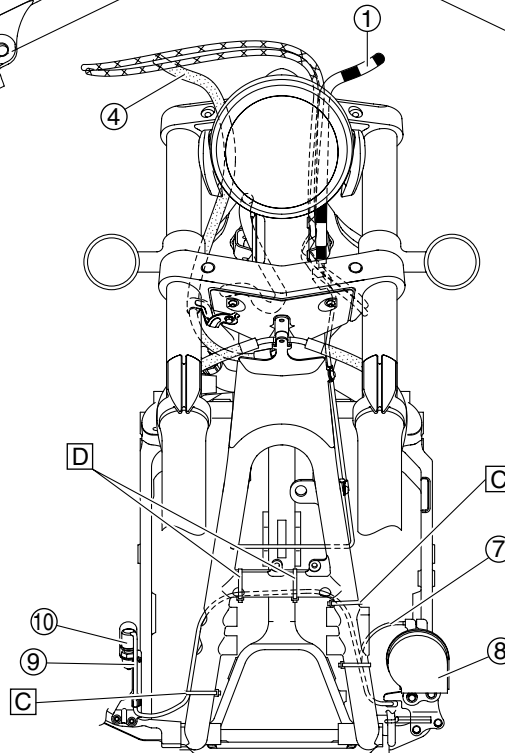
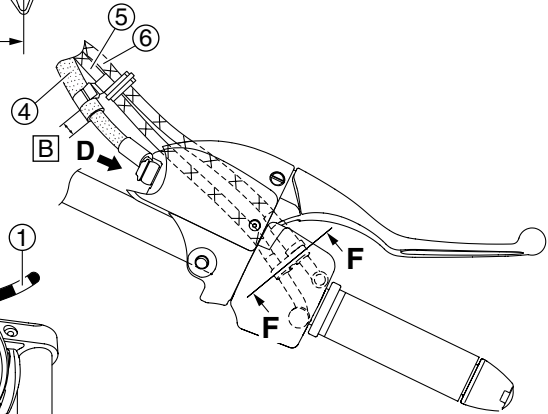
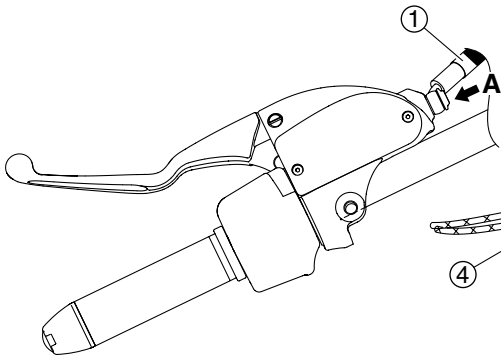

CABLE ROUTING (for XV19CS(C)/ XV19C(C))

1. Clutch hose
 2. Left handlebar switch lead
 3. Right handlebar switch lead
 4. Front brake hose
 5. Throttle cable (decelerator cable)
 6. Throttle cable (accelerator cable)
 7. Horn 1 lead
 8. Horn 1
 9. Rear brake light switch lead
 10. Rear brake light switch
- A. Pass the left handlebar switch lead through the grommet.
 - B. 5–15 mm (0.20–0.59 in)
 - C. Fasten the rear brake light switch lead with a plastic locking tie. Face the end of the plastic locking tie inward, and then cut off the excess end of the tie.
 - D. Fasten the rear brake light switch lead with a plastic locking tie. Face the end of the plastic locking tie downward, and then cut off the excess end of the tie.
 - E. 15–35°
 - F. Pass the right handlebar switch lead through the cutouts in the lead holder.
 - G. Do not pinch the right handlebar switch lead.

CABLE ROUTING (for XV19CS(C)/ XV19C(C))

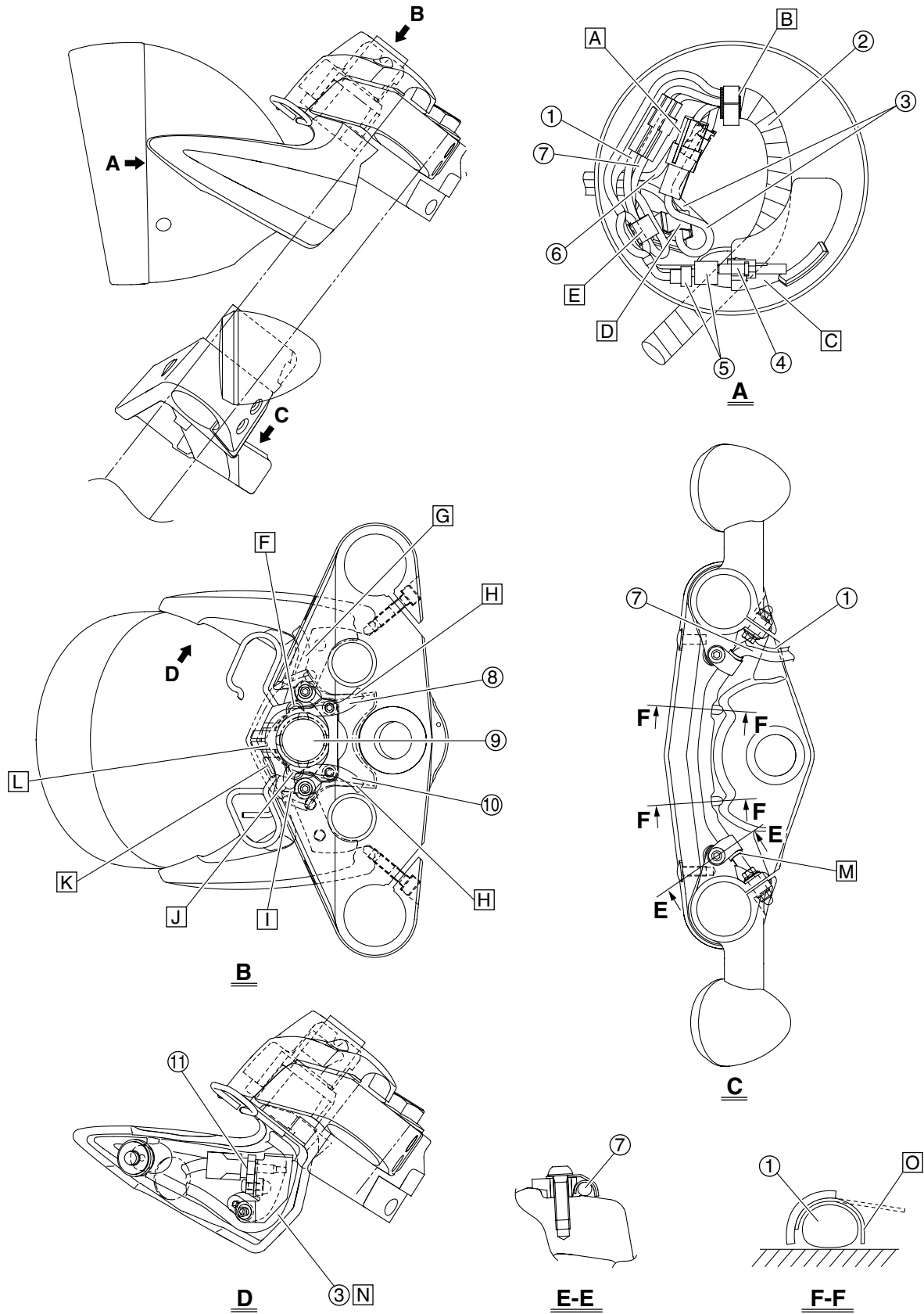

CABLE ROUTING (for XV19CS(C)/ XV19C(C))

1. Front right turn signal/position light lead
2. Wire harness
3. Main switch lead
4. Accessory light coupler
5. Joint coupler
6. Air temperature sensor lead
7. Front left turn signal/position light lead
8. Right handlebar switch lead
9. Main switch
10. Left handlebar switch lead
11. Air temperature sensor
- A. Position the main switch coupler in the rear of the headlight housing.
- B. Fasten the wire harness at the white tape with the holder.
- C. Position the accessory light coupler and joint coupler in front of the plate.
- D. Fasten the main switch lead with the holder.
- E. Fasten the front left turn signal/position light lead, front right turn signal/position light lead, and joint coupler lead with the holder.
- F. Fit the right handlebar switch lead in between the grommet and the main switch cover bracket, making sure to push the lead all the way down.
- G. Route the main switch lead under the headlight bracket.
- H. Pass the left and right handlebar switch leads through the cutouts in the main switch cover.
- I. Pass the left and right handlebar switch leads between the cable guide and the upper bracket.
- J. Fit the left handlebar switch lead in between the grommet and the main switch cover bracket, making sure to push the lead all the way down.
- K. Fit the right handlebar switch lead in between the main switch and the cable guide, making sure to push the lead all the way in.
- L. Route the right handlebar switch lead along the grommet.
- M. Pass the front left turn signal/position light lead through the lead guide.
- N. Route the main switch lead behind the plate.
- O. Bend the projection on the lead guide to fasten the front right turn signal/position light lead.

CABLE ROUTING (for XV19CS(C)/ XV19C(C))

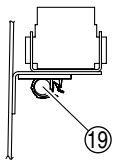
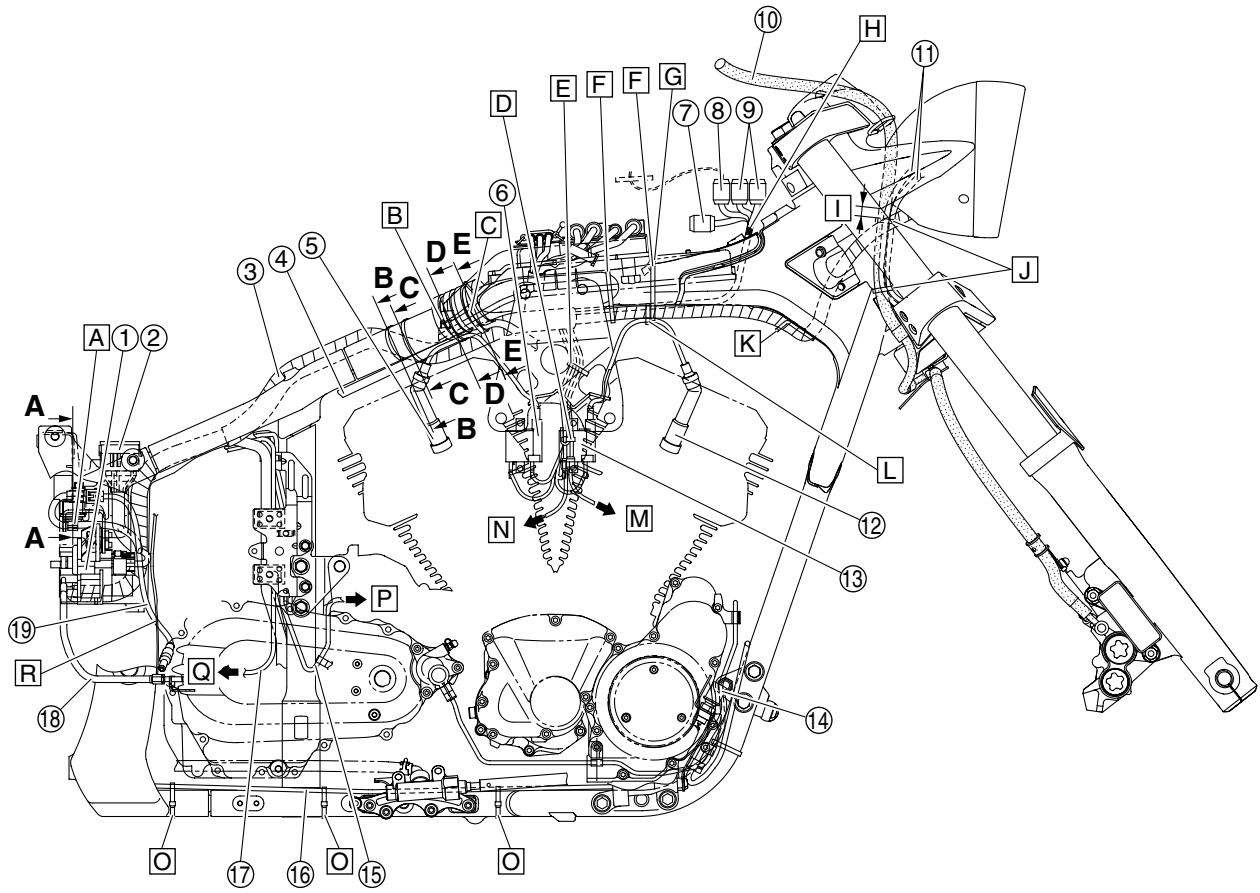

A-A

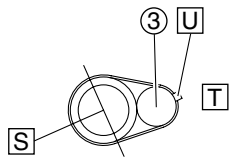

B-B

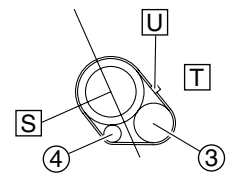

C-C

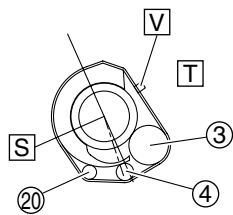

D-D

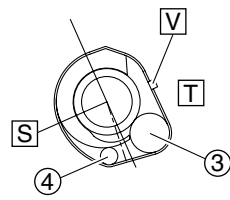

E-E

CABLE ROUTING (for XV19CS(C)/ XV19C(C))

1. EXUP servo motor
2. Fuse box
3. Wire harness
4. Fuel outlet hose
5. Cylinder-#1 right spark plug cap
6. Cylinder-#1 right ignition coil
7. Cylinder-#2 intake air pressure sensor coupler
8. Fuel sender (fuel tank) coupler
9. Meter assembly coupler
10. Front brake hose
11. Front turn signal/position light lead
12. Cylinder-#2 right spark plug cap
13. Cylinder-#2 right ignition coil
14. Rear brake light switch
15. Neutral switch lead
16. Stator coil lead
17. Speed sensor lead
18. EXUP cable
19. O₂ sensor lead
20. Cylinder-#1 right spark plug lead
 - A. Fasten the sub-wire harness with the holder.
 - B. Fasten the cylinder-#1 right spark plug lead, fuel outlet hose, wire harness and the fuel tank damper with a plastic locking tie. Install the plastic locking tie in the rear slot of the fuel tank damper.
 - C. Fasten the fuel outlet hose, wire harness, and fuel tank damper with a plastic locking tie. Install the plastic locking tie in the front slot of the fuel tank damper and make sure that the end of the damper is aligned with the edge of the flat section on the outside of the frame.
 - D. Fasten the wire harness to the guide on the engine bracket (right upper side) with a plastic locking tie, and then cut off the excess end of the tie.
 - E. Fasten the wire harness to the right ignition coil bracket with a plastic locking tie.
 - F. Fasten the wire harness and meter assembly lead to the frame with plastic locking ties. Face the end of each plastic locking tie inward, and then cut off the excess end of the tie.
 - G. Position the plastic locking tie to the front of the projection on the frame.
 - H. Align the positioning tape on the wire harness with the top of the frame.
 - I. 10 mm (0.39 in)
 - J. Fasten the front turn signal/position light leads to the front brake hose with a plastic locking tie. Position the buckle of the plastic locking tie to the outside of the front brake hose, with the end of the tie facing outward, and then cut off the excess end of the tie.
 - K. Pass the wire harness through the guide.
 - L. Fasten the wire harness and cylinder-#2 right spark plug lead to the frame with a plastic locking tie. Face the end of the plastic locking tie downward, and then cut off the excess end of the tie.
 - M. To the throttle position sensor
 - N. To the fuel injectors and engine temperature sensor
 - O. Fasten the stator coil lead with a plastic locking tie. Position the buckle of the plastic locking tie to the outside of the frame, with the end of the tie facing downward, and then cut off the excess end of the tie.
 - P. To the neutral switch
 - Q. To the speed sensor
 - R. Pass the O₂ sensor lead through the cutout in the heat protector.
 - S. Outside of the frame
 - T. Inside of the frame
 - U. Position the buckle of the plastic locking tie to the inside of the frame. Face the end of the plastic locking tie upward, and then cut off the excess end of the tie.
 - V. Position the buckle of the plastic locking tie to the inside of the frame.

CABLE ROUTING (for XV19CS(C)/ XV19C(C))

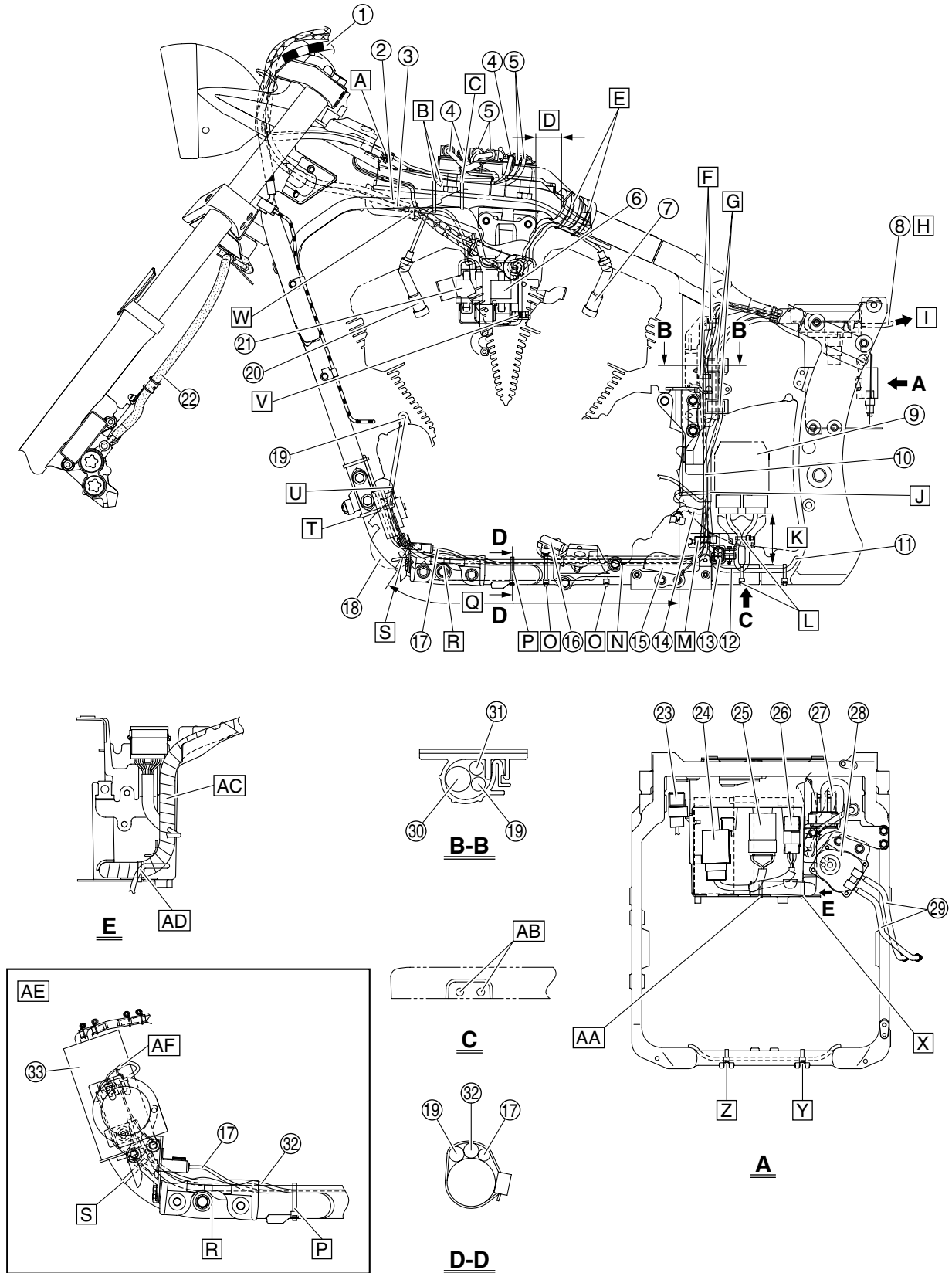

CABLE ROUTING (for XV19CS(C)/ XV19C(C))

1. Clutch hose
 2. Throttle cable (accelerator cable)
 3. Throttle cable (decelerator cable)
 4. Right handlebar switch coupler
 5. Left handlebar switch coupler
 6. Cylinder-#1 left ignition coil
 7. Cylinder-#1 left spark plug cap
 8. Sub-wire harness 1
 9. Rectifier/regulator
 10. Crankshaft position sensor lead
 11. Stator coil lead
 12. Rectifier/regulator lead
 13. Lean angle sensor
 14. Horn 2 lead
 15. Horn 2
 16. Sidestand switch
 17. Rear brake light switch lead
 18. Horn 1
 19. Starter motor lead
 20. Cylinder-#2 left spark plug cap
 21. Cylinder-#2 left ignition coil
 22. Front brake hose
 23. Main fuse
 24. Turn signal relay
 25. Relay unit
 26. Headlight relay
 27. Starter relay
 28. EXUP servo motor
 29. EXUP cable
 30. Wire harness
 31. Speed sensor lead
 32. Horn 1 lead
 33. Canister
- A. Fasten the left and right handlebar switch leads at the positioning tape on each lead with a plastic locking tie. Face the end of the plastic locking tie inward, and then cut off the excess end of the tie.
- B. Fasten the left and right handlebar switch leads, and cylinder-#2 left spark plug lead to the frame with a plastic locking tie. Position the plastic locking tie to the front of the projection on the frame. Face the end of the plastic locking tie inward, and then cut off the excess end of the tie.
- C. Fasten the left and right handlebar switch leads to the frame with a plastic locking tie. Face the end of the plastic locking tie inward, and then cut off the excess end of the tie.
- D. 30–40 mm (1.18–1.57 in)
- E. Fasten the left ignition coil lead and cylinder-#1 left spark plug lead with plastic locking ties. Face the end of each plastic locking tie inward, and then cut off the excess end of the tie.
- F. Fasten the crankshaft position sensor lead, neutral switch lead and sidestand switch lead with the holders.
- G. Fasten the starter motor lead, speed sensor lead and wire harness with the holders.
- H. Route sub-wire harness 1 to the inside of the frame.
- I. To the tail/brake light
- J. Fasten the starter motor lead, horn 1 lead, rear brake light switch lead, sidestand switch lead, crankshaft position sensor lead and rectifier/regulator lead to the frame with a plastic locking tie.
- K. Make sure that there is no slack in the stator coil lead and rectifier/regulator lead in the area shown in the illustration.
- L. Fasten the stator coil lead and rectifier/regulator lead with a plastic locking tie. Face the end of the plastic locking tie outward, and then cut off the excess end of the tie.
- M. Fasten the lean angle sensor lead, starter motor lead, horn 1 lead, rear brake light switch lead, and sidestand switch lead with the holder.
- N. Route the starter motor lead, horn 1 lead, rear brake light switch lead, and sidestand switch lead to the inside of the frame boss.
- O. Fasten the starter motor lead, horn 1 lead, rear brake light switch lead, and sidestand switch lead with plastic locking ties. Face the end of the plastic locking tie outward, and then cut off the excess end of the tie.
- P. Fasten the starter motor lead, horn 1 lead, and rear brake light switch lead with a plastic locking tie, and then face the end of the tie outward. Be sure to install the plastic locking tie behind the frame cross member and to fasten the rear brake light switch lead at the white tape.
- Q. Route the starter motor lead, horn 1 lead, and rear brake light switch lead along the frame in the area shown in the illustration, making sure not to cross the leads.
- R. Align the positioning tape on the starter motor lead with the engine mounting bolt (front lower side).
- S. Fasten the starter motor lead, horn 1 lead, and rear brake light switch lead with a plastic locking tie, and then face the end of the tie inward.
- T. Fasten the horn 1 lead, rear brake light switch lead, and starter motor lead with a plastic locking tie. Face the end of the plastic locking tie inward, and then cut off the excess end of the tie.
- U. Route the horn 1 lead to the rear of the starter motor lead.
- V. Fasten the ignition coil lead at the white tape with the holder.
- W. Fasten the throttle cable (decelerator cable) at the white paint mark with the holder.
- X. Pass the plastic locking tie through the hole in the rubber plate, and then fasten the wire harness with the tie.
- Y. Fasten the stator coil lead at the white tape with a plastic locking tie.
- Z. Fasten the stator coil lead with a plastic locking tie.
- AA. Pass the plastic locking tie through the hole in the battery box projection, and then fasten the wire harness with the tie.
- AB. Install the lead cover, making sure not to pinch the stator coil lead and rectifier/regulator lead.
- AC. Route the wire harness along the side of the fuse box/starter relay bracket.
- AD. Pass the plastic locking tie through the hole in the battery box projection, and then fasten the wire harness with the tie.
- AE. For California only
- AF. Route the horn 1 lead to the rear of the canister.

CABLE ROUTING (for XV19CS(C)/ XV19C(C))

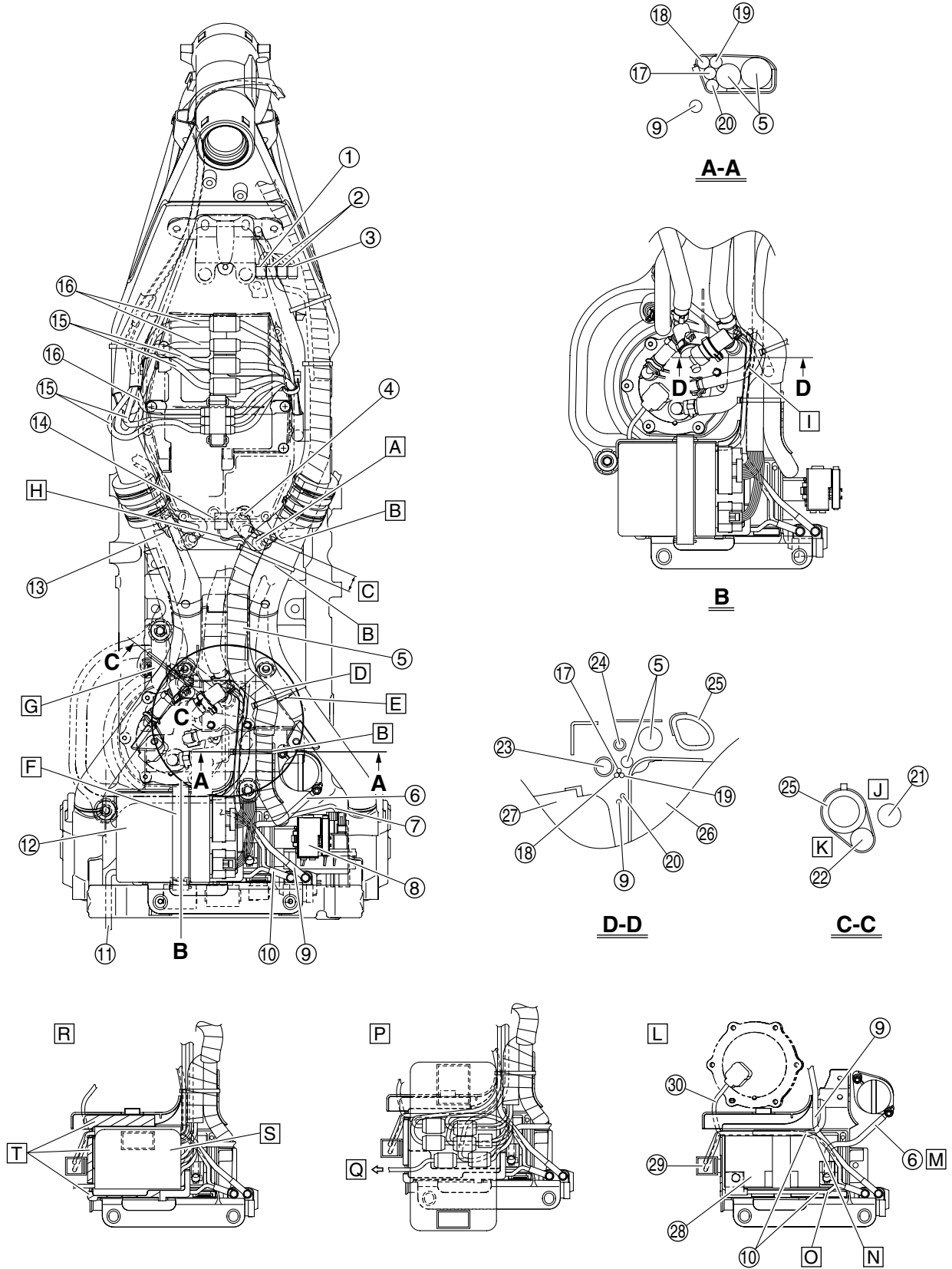

CABLE ROUTING (for XV19CS(C)/ XV19C(C))

1. Cylinder-#2 intake air pressure sensor coupler
 2. Meter assembly coupler
 3. Fuel sender (fuel tank) coupler
 4. Cylinder-#1 right spark plug cap
 5. Wire harness
 6. Negative battery lead
 7. EXUP servo motor lead
 8. Fuse box
 9. Starter motor lead
 10. Positive battery lead
 11. Sub-wire harness 1
 12. ECU (electronic control unit)
 13. Cylinder-#1 left spark plug cap
 14. Cylinder-#1 intake air pressure sensor coupler
 15. Left handlebar switch lead
 16. Right handlebar switch lead
 17. Neutral switch lead
 18. Sidestand switch lead
 19. Crankshaft position sensor lead
 20. Speed sensor lead
 21. Fuel hose (fuel tank to fuel hose joint)
 22. Fuel return hose (fuel return pipe to sub-fuel tank)
 23. Air vent hose (fuel pump to fuel hose joint)
 24. Fuel outlet hose
 25. Frame
 26. Oil tank
 27. Sub-fuel tank
 28. Battery
 29. Main fuse
 30. Fuel pump lead
- A. Align the white tape on the wire harness with the frame cross member.
 - B. Fasten the wire harness with a plastic locking ties. Face the end of the plastic locking tie upward, and then cut off the excess end of the tie.
 - C. 20 mm (0.79 in)
 - D. Route the wire harness along the frame.
 - E. Fasten the wire harness with a plastic locking tie, making sure to align the tie with the line on the rubber damper. Face the end of the plastic locking tie upward, and then cut off the excess end of the tie.
 - F. Connect the ECU couplers, and then fasten the ECU with the band.
 - G. Fasten the fuel return hose (fuel return pipe to sub-fuel tank) to the frame with a plastic locking tie. Face the end of the plastic locking tie inward, and then cut off the excess end of the tie.
 - H. Route the cylinder-#1 intake air pressure sensor lead so that it does not protrude past the top of the frame.
 - I. Route the crankshaft position sensor lead, sidestand switch lead, neutral switch lead, starter motor lead and speed sensor lead under the fuel outlet hose.
 - J. Inside of frame
 - K. Outside of frame
 - L. View with tray removed
 - M. Route the negative battery lead under the starter motor lead and battery positive lead.
 - N. Route the positive battery lead (main fuse to starter relay) over the tray.
 - O. Route the positive battery lead (battery to starter relay) under the tray.
 - P. View with tray installed
 - Q. To the tail/brake light
 - R. View with ECU removed
 - S. Wrap the protective covering around the couplers (crankshaft position sensor coupler, auxiliary DC coupler, neutral switch coupler, sub-wire harness 1 coupler, speed sensor coupler, sidestand switch coupler, and joint coupler).
 - T. When installing the ECU, be sure not to pinch the leads in the areas shown in the illustration with oblique lines.

CABLE ROUTING (for XV19CS(C)/ XV19C(C))

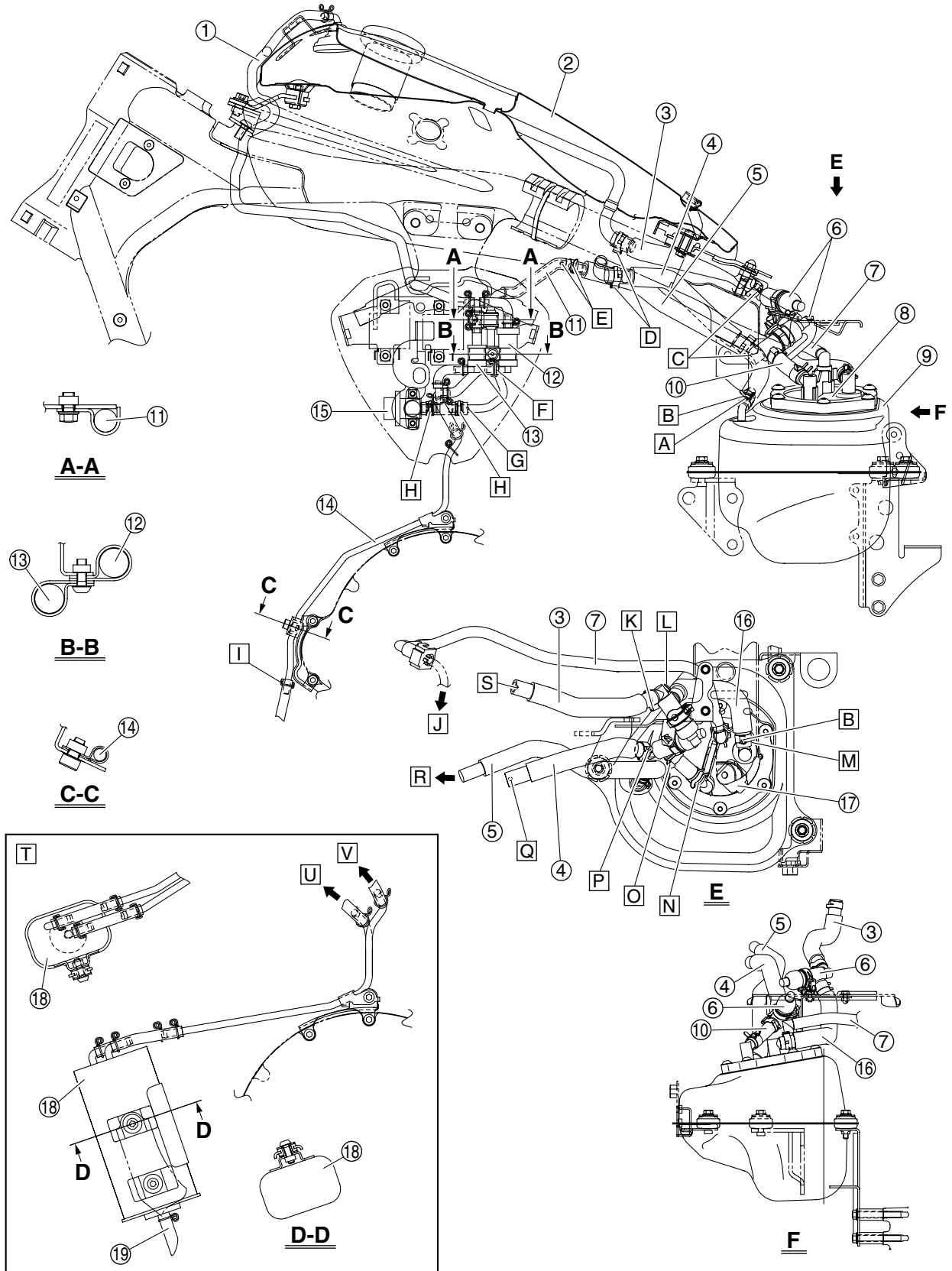

CABLE ROUTING (for XV19CS(C)/ XV19C(C))

1. Fuel tank breather hose
2. Fuel tank
3. Air vent hose (fuel hose joint to fuel tank)
4. Fuel hose (fuel tank to fuel hose joint)
5. Fuel return hose (fuel return pipe to sub-fuel tank)
6. Fuel hose joint
7. Fuel outlet hose
8. Fuel pump
9. Sub-fuel tank
10. Fuel hose (fuel pump to fuel hose joint)
11. Fuel return pipe
12. Rollover valve 2
13. Rollover valve 1
14. Fuel tank breather/overflow pipe
15. Pressure regulator
16. Air vent hose (fuel pump to fuel hose joint)
17. Fuel pump coupler
18. Canister (for California only)
19. Canister breather hose (for California only)
- A. Install the fuel return hose (fuel return pipe to sub-fuel tank) with its white paint mark facing upward.
- B. Position the hose clamp over the white paint mark on the hose, making sure not to install it on the raised portion of the pipe.
- C. Align the yellow paint mark on the air vent hose (fuel hose joint to fuel tank) and fuel return hose (fuel return pipe to sub-fuel tank) with the fuel hose joint.
- D. Face the fastener of the clamp downward, making sure that the projections on the clamp are positioned as shown in the illustration.
- E. Align the white paint mark on the end of the fuel return hose (fuel return pipe to sub-fuel tank) with the white paint mark on the fuel return pipe.
- F. Face the ends of the hose clamp outward.
- G. Install the fuel return hose onto the fuel return pipe until the hose contacts the white paint mark on the pipe.
- H. Align the ends of the hose clamps with the white paint marks on the fuel return hose.
- I. Face the ends of the hose clamp inward.
- J. To the fuel injector
- K. Align the clamp with the yellow paint mark, making sure to face the fastener of the clamp to the left.
- L. Face the ends of the hose clamp forward.
- M. Install the air vent hose (fuel pump to fuel hose joint) with its white paint mark facing upward.
- N. Face the ends of the hose clamp upward.
- O. Face the fastener of the clamp to the left.
- P. Face the fastener of the clamp to the left. The projections on the clamp may be facing in any direction.
- Q. Install the fuel hose (fuel tank to fuel hose joint) with its white paint mark facing downward.
- R. To the pressure regulator
- S. Install the air vent hose (fuel hose joint to fuel tank) with its white paint mark facing downward.
- T. For California only
- U. To the fuel tank
- V. To the rollover valve

CABLE ROUTING (for XV19CS(C)/ XV19C(C))

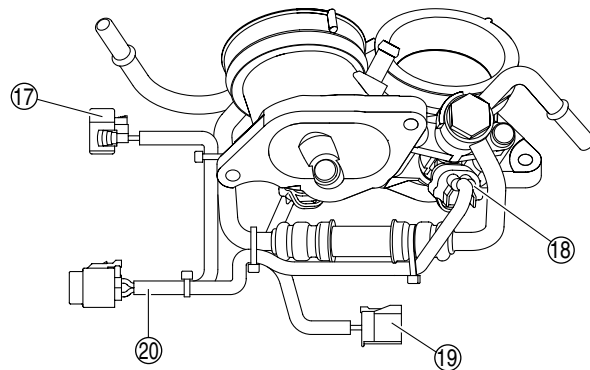
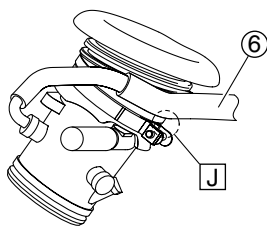
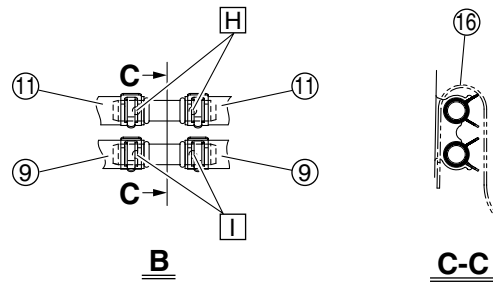
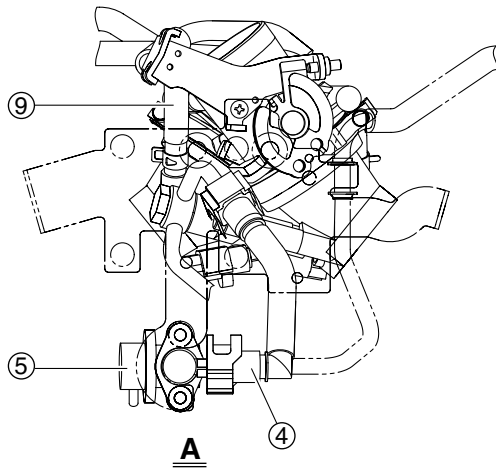
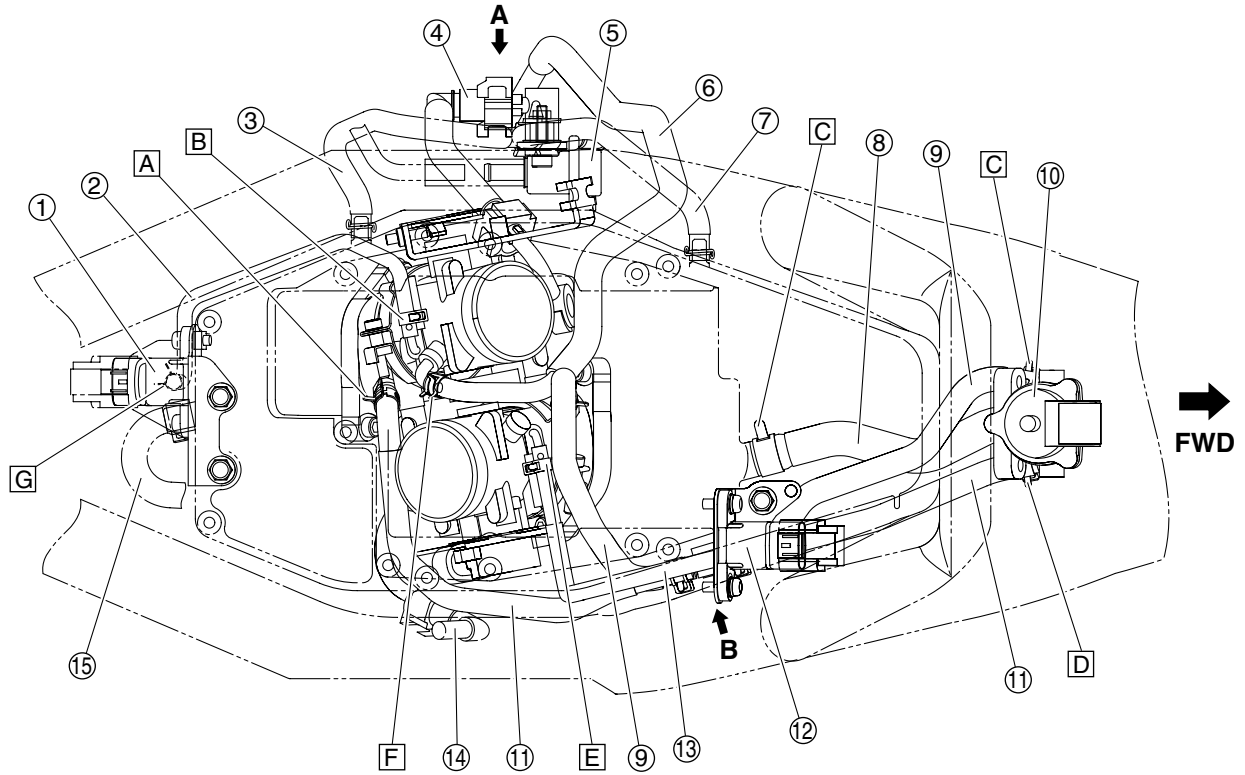

CABLE ROUTING (for XV19CS(C)/ XV19C(C))

1. Cylinder-#1 intake air pressure sensor
2. Cylinder-#1 intake air pressure sensor hose
3. Air filter case breather hose 1
4. Fuel hose (intake manifold assembly to pressure regulator)
5. Pressure regulator
6. Canister purge hose (for California only)
7. Air filter case breather hose 2
8. ISC (idle speed control) unit inlet hose
9. Cylinder-#2 ISC (idle speed control) unit outlet hose
10. ISC (idle speed control) unit
11. Cylinder-#1 ISC (idle speed control) unit outlet hose
12. Cylinder-#2 intake air pressure sensor
13. Cylinder-#2 intake air pressure sensor hose
14. Fuel outlet hose
15. Cylinder head breather hose
16. Hose joint cover
17. Throttle position sensor coupler
18. Cylinder-#1 injector coupler
19. Engine temperature sensor coupler
20. Sub-wire harness 2
 - A. Face the ends of the hose clamp to the left, angled 45° rearward.
 - B. Install the cylinder-#1 intake air pressure sensor hose onto the throttle body pipe up to the bend in the pipe, making sure to face the white paint mark on the hose upward. Face the ends of the hose clamp forward.
 - C. Face the ends of the hose clamp to the left.
 - D. Face the ends of the hose clamp to the right.
 - E. Install the cylinder-#2 intake air pressure sensor hose onto the throttle body pipe up to the bend in the pipe, making sure to face the yellow paint mark on the hose upward. Face the ends of the hose clamp rearward.
 - F. Install the canister purge hose onto the throttle body pipe up to the bend in the pipe, making sure to face the yellow paint mark on the hose upward (for California only).
 - G. Face the ends of the hose clamp rearward, angled to the left.
 - H. Align the white paint marks.
 - I. Align the yellow paint marks.
 - J. Route the canister purge hose over the air filter case joint clamp screw (for California only).

CABLE ROUTING (for XV19CS(C)/ XV19C(C))

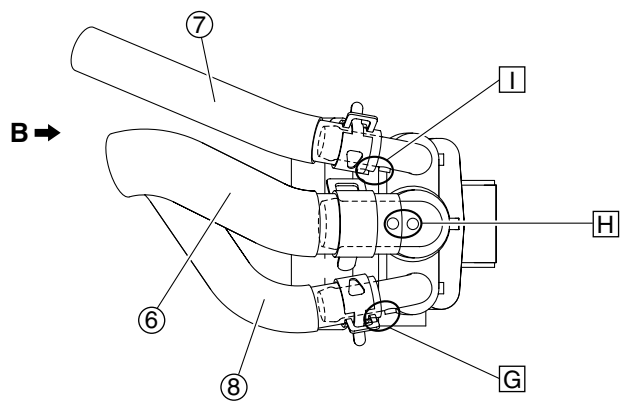
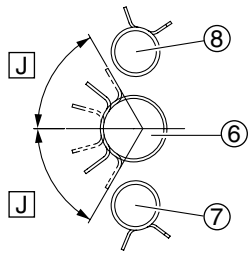
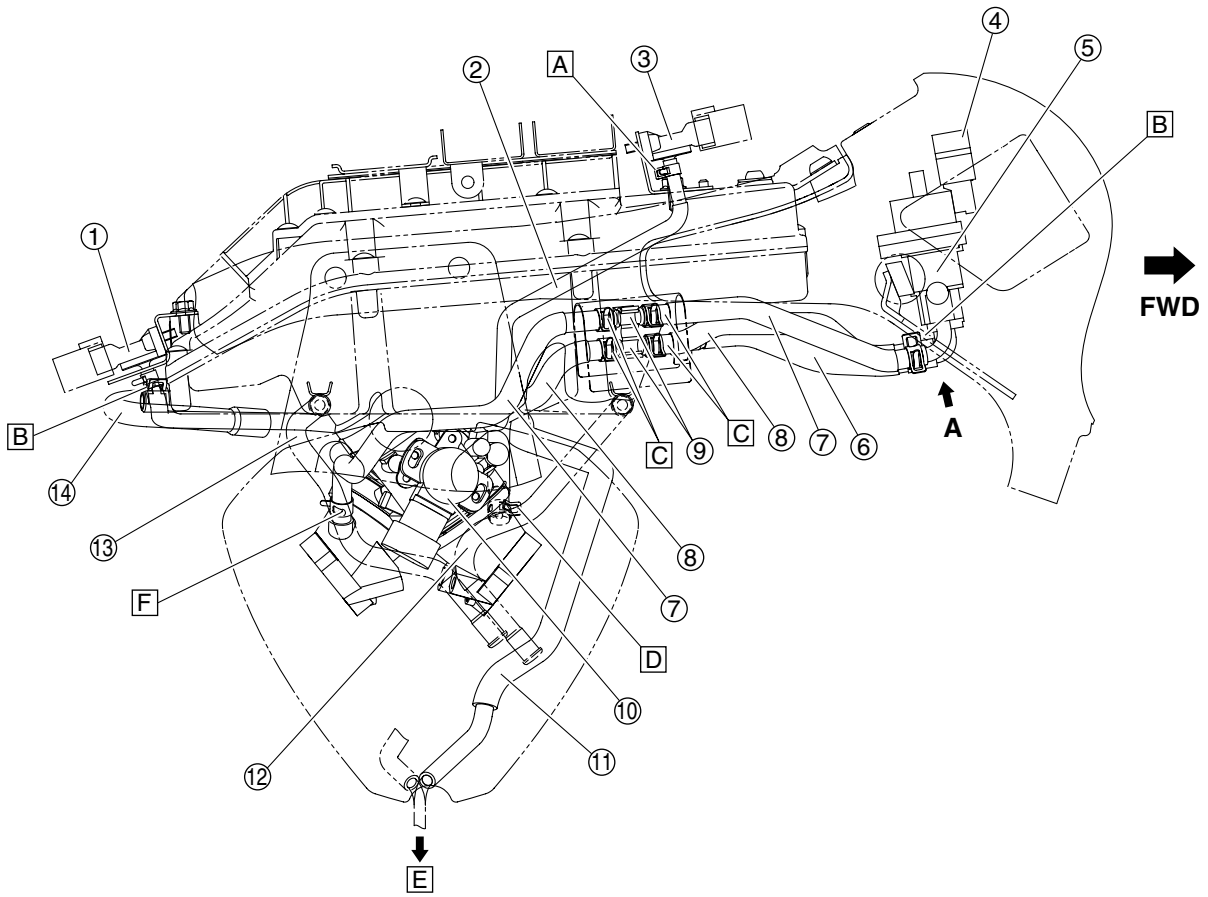

CABLE ROUTING (for XV19CS(C)/ XV19C(C))

1. Cylinder-#1 intake air pressure sensor
2. Cylinder-#2 intake air pressure sensor hose
3. Cylinder-#2 intake air pressure sensor
4. ISC (idle speed control) unit coupler
5. ISC (idle speed control) unit
6. ISC (idle speed control) unit inlet hose
7. Cylinder-#1 ISC (idle speed control) unit outlet hose
8. Cylinder-#2 ISC (idle speed control) unit outlet hose
9. Hose joint
10. Throttle position sensor
11. Canister purge hose (for California only)
12. Air filter case breather hose 2
13. Air filter case breather hose 1
14. Cylinder head breather hose
- A. Face the ends of the hose clamp rearward.
- B. Face the ends of the hose clamp outward.
- C. Face the ends of the hose clamps outward.
- D. Install the cylinder-#2 ISC (idle speed control) unit outlet hose (hose joint to intake manifold assembly) completely onto the intake manifold, making sure to face the pink paint mark on the hose to the left. Face the ends of the hose clamp outward, angled 45° forward.
- E. To the canister (for California only)
- F. Install the cylinder-#1 ISC (idle speed control) unit outlet hose (hose joint to intake manifold assembly) completely onto the intake manifold, making sure to face the red paint mark on the hose to the left.
- G. Install the cylinder-#2 ISC (idle speed control) unit outlet hose onto the ISC unit pipe, making sure to align the green paint mark on the hose with the green paint mark on the pipe.
- H. Install the ISC (idle speed control) unit inlet hose onto the ISC unit pipe, making sure to align the white paint mark on the hose with the white paint mark on the pipe.
- I. Install the cylinder-#1 ISC (idle speed control) unit outlet hose onto the ISC unit pipe, making sure to align the blue paint mark on the hose with the blue paint mark on the pipe.
- J. 60°

PERIODIC CHECKS AND ADJUSTMENTS

PERIODIC MAINTENANCE	3-1
INTRODUCTION	3-1
PERIODIC MAINTENANCE CHART FOR THE EMISSION CONTROL SYSTEM.....	3-1
GENERAL MAINTENANCE AND LUBRICATION CHART	3-1
ENGINE	3-4
ADJUSTING THE VALVE CLEARANCE	3-4
SYNCHRONIZING THE THROTTLE BODIES.....	3-7
ADJUSTING THE THROTTLE CABLE FREE PLAY	3-8
CHECKING THE SPARK PLUGS	3-9
CHECKING THE IGNITION TIMING	3-10
CHECKING THE ENGINE OIL LEVEL.....	3-11
CHANGING THE ENGINE OIL	3-11
CHECKING THE TRANSFER GEAR OIL LEVEL.....	3-13
CHANGING THE TRANSFER GEAR OIL.....	3-14
CHECKING THE CLUTCH FLUID LEVEL	3-14
BLEEDING THE HYDRAULIC CLUTCH SYSTEM	3-15
REPLACING THE AIR FILTER ELEMENT	3-15
CHECKING THE THROTTLE BODY JOINTS	3-16
CHECKING THE FUEL LINE	3-16
CHECKING THE CYLINDER HEAD BREATHER HOSE	3-17
CHECKING THE OIL TANK BREATHER HOSE	3-17
CHECKING THE EXHAUST SYSTEM (for XV19S(C)/ XV19M(C)/ XV19CTS(C)/ XV19CTM(C)).....	3-17
CHECKING THE EXHAUST SYSTEM (for XV19CS(C)/ XV19C(C)).....	3-18
CHECKING THE CANISTER (for California only) (for XV19SC/ XV19MC/ XV19CTSC/ XV19CTMC)	3-19
CHECKING THE CANISTER (for California only) (for XV19CSC/ XV19CC)	3-19
ADJUSTING THE EXUP CABLES	3-19

CHASSIS	3-21
ADJUSTING THE REAR DISC BRAKE	3-21
CHECKING THE BRAKE FLUID LEVEL.....	3-21
CHECKING THE FRONT BRAKE PADS	3-22
CHECKING THE REAR BRAKE PADS	3-22
CHECKING THE FRONT BRAKE HOSES	3-23
CHECKING THE REAR BRAKE HOSES.....	3-23
ADJUSTING THE REAR BRAKE LIGHT SWITCH	3-23
BLEEDING THE HYDRAULIC BRAKE SYSTEM	3-24
ADJUSTING THE SHIFT PEDAL.....	3-25
ADJUSTING THE DRIVE BELT SLACK	3-26
CHECKING AND ADJUSTING THE STEERING HEAD	3-27
CHECKING THE FRONT FORK.....	3-28
ADJUSTING THE REAR SHOCK ABSORBER ASSEMBLY	3-28
CHECKING THE TIRES.....	3-29
CHECKING THE WHEELS	3-31
CHECKING AND LUBRICATING THE CABLES	3-31
LUBRICATING THE LEVERS	3-32
LUBRICATING THE PEDALS	3-32
LUBRICATING THE SIDESTAND.....	3-32
LUBRICATING THE REAR SUSPENSION.....	3-32
ELECTRICAL SYSTEM	3-33
CHECKING AND CHARGING THE BATTERY	3-33
CHECKING THE FUSES	3-33
REPLACING THE HEADLIGHT BULBS (for XV19S(C)/ XV19M(C)/ XV19CTS(C)/ XV19CTM(C)).....	3-33
REPLACING THE HEADLIGHT BULB (for XV19CS(C)/ XV19C(C)).....	3-34
ADJUSTING THE HEADLIGHT BEAMS.....	3-35



PERIODIC MAINTENANCE

EAS20450

PERIODIC MAINTENANCE

EAS20460

INTRODUCTION

This chapter includes all information necessary to perform recommended checks and adjustments. If followed, these preventive maintenance procedures will ensure more reliable vehicle operation, a longer service life and reduce the need for costly overhaul work. This information applies to vehicles already in service as well as to new vehicles that are being prepared for sale. All service technicians should be familiar with this entire chapter.

EAU17600

PERIODIC MAINTENANCE CHART FOR THE EMISSION CONTROL SYSTEM

No.	ITEM	ROUTINE	INITIAL	ODOMETER READINGS					
			600 mi (1000 km) or 1 month	4000 mi (7000 km) or 6 months	8000 mi (13000 km) or 12 months	12000 mi (19000 km) or 18 months	16000 mi (25000 km) or 24 months	20000 mi (31000 km) or 30 months	
1	* Fuel line	<ul style="list-style-type: none"> Check fuel hoses for cracks or damage. Replace if necessary. 		√	√	√	√	√	√
2	* Spark plugs	<ul style="list-style-type: none"> Check condition. Adjust gap and clean. Replace every 8000 mi (13000 km) or 12 months. 		√	Replace.	√	Replace.		√
3	* Valve clearance	<ul style="list-style-type: none"> Check and adjust valve clearance when engine is cold. Adjust if necessary. 	Every 16000 mi (25000 km)						
4	* Crankcase breather system	<ul style="list-style-type: none"> Check breather hose for cracks or damage. Replace if necessary. 		√	√	√	√	√	√
5	* Fuel injection	<ul style="list-style-type: none"> Adjust synchronization. 		√	√	√	√	√	√
6	* Exhaust system	<ul style="list-style-type: none"> Check for leakage. Tighten if necessary. Replace gasket(s) if necessary. 		√	√	√	√	√	√
7	* Evaporative emission control system (for California only)	<ul style="list-style-type: none"> Check control system for damage. Replace if necessary. 				√			√

* Since these items require special tools, data and technical skills, have a Yamaha dealer perform the service.

EAU32185

GENERAL MAINTENANCE AND LUBRICATION CHART

No.	ITEM	ROUTINE	INITIAL	ODOMETER READINGS					
			600 mi (1000 km) or 1 month	4000 mi (7000 km) or 6 months	8000 mi (13000 km) or 12 months	12000 mi (19000 km) or 18 months	16000 mi (25000 km) or 24 months	20000 mi (31000 km) or 30 months	
1	* Air filter element	<ul style="list-style-type: none"> Check condition and for damage. Replace if necessary. 		√	√	√	√	√	√
2	* Clutch	<ul style="list-style-type: none"> Check operation and fluid leakage. Correct if necessary. 	√	√	√	√	√	√	√
3	* Front brake	<ul style="list-style-type: none"> Check operation, fluid level, and for fluid leakage. Replace brake pads if necessary. 	√	√	√	√	√	√	√
4	* Rear brake	<ul style="list-style-type: none"> Check operation, fluid level, and for fluid leakage. Replace brake pads if necessary. 	√	√	√	√	√	√	√
5	* Brake hoses	<ul style="list-style-type: none"> Check for cracks or damage. Replace. 		√	√	√	√	√	√
			Every 4 years						

PERIODIC MAINTENANCE

No.	ITEM	ROUTINE	INITIAL	ODOMETER READINGS					
			600 mi (1000 km) or 1 month	4000 mi (7000 km) or 6 months	8000 mi (13000 km) or 12 months	12000 mi (19000 km) or 18 months	16000 mi (25000 km) or 24 months	20000 mi (31000 km) or 30 months	
6	* Wheels	<ul style="list-style-type: none"> Check runout and for damage. Replace if necessary. 		√	√	√	√	√	√
7	* Tires	<ul style="list-style-type: none"> Check tread depth and for damage. Replace if necessary. Check air pressure. Correct if necessary. 		√	√	√	√	√	√
8	* Wheel bearings	<ul style="list-style-type: none"> Check bearings for smooth operation. Replace if necessary. 		√	√	√	√	√	√
9	* Swingarm pivot bearings	<ul style="list-style-type: none"> Check bearing assemblies for looseness. 		√	√	√	√	√	√
10	* Drive belt	<ul style="list-style-type: none"> Check belt tension. Adjust if necessary. 	√	Every 2500 mi (4000 km)					
11	* Steering bearings	<ul style="list-style-type: none"> Check bearing assemblies for looseness. Moderately repack with lithium-soap-based grease every 16000 mi (25000 km) or 24 months. 	√	√	√	√	Repack.	√	√
12	* Chassis fasteners	<ul style="list-style-type: none"> Check all chassis fitting and fasteners. Correct if necessary. 		√	√	√	√	√	√
13	Brake lever pivot shaft	<ul style="list-style-type: none"> Apply silicone grease lightly. 		√	√	√	√	√	√
14	Brake pedal pivot shaft	<ul style="list-style-type: none"> Apply lithium-soap-based grease (all-purpose grease) lightly. 		√	√	√	√	√	√
15	Clutch lever pivot shaft	<ul style="list-style-type: none"> Apply silicone grease lightly. 		√	√	√	√	√	√
16	Shift pedal pivot shaft	<ul style="list-style-type: none"> Apply lithium-soap-based grease (all-purpose grease) lightly. 		√	√	√	√	√	√
17	Sidestand pivot	<ul style="list-style-type: none"> Check operation. Apply lithium-soap-based grease (all-purpose grease) lightly. 		√	√	√	√	√	√
18	* Sidestand switch	<ul style="list-style-type: none"> Check operation and replace if necessary. 	√	√	√	√	√	√	√
19	* Front fork	<ul style="list-style-type: none"> Check operation and for oil leakage. Replace if necessary. 		√	√	√	√	√	√
20	* Shock absorber assembly	<ul style="list-style-type: none"> Check operation and for oil leakage. Replace if necessary. 		√	√	√	√	√	√
21	* Rear suspension link pivots	<ul style="list-style-type: none"> Apply lithium-soap-based grease lightly. 					√		
22	Engine oil	<ul style="list-style-type: none"> Change (warm engine before draining). 	√	√	√	√	√	√	√
23	* Engine oil filter cartridge	<ul style="list-style-type: none"> Replace. 	√		√		√		
24	* Transfer case oil	<ul style="list-style-type: none"> Check for leakage. Change at initial 600 mi (1000 km) or 1 month, and thereafter every 16000 mi (25000 km) or 24 months. 	Change.		√		Change.		
25	* Front and rear brake switches	<ul style="list-style-type: none"> Check operation. 	√	√	√	√	√	√	√
26	* Control cables	<ul style="list-style-type: none"> Apply Yamaha chain and cable lube or engine oil SAE 10W-30 thoroughly. 	√	√	√	√	√	√	√
27	* Throttle grip housing and cable	<ul style="list-style-type: none"> Check operation and free play. Adjust the throttle cable free play if necessary. Lubricate the throttle grip housing and cable. 		√	√	√	√	√	√
28	* Lights, signals and switches	<ul style="list-style-type: none"> Check operation. Adjust headlight beam. 	√	√	√	√	√	√	√

PERIODIC MAINTENANCE

* Since these items require special tools, data and technical skills, have a Yamaha dealer perform the service.

NOTE: _____

From 24000 mi (37000 km) or 36 months, repeat the maintenance intervals starting from 8000 mi (13000 km) or 12 months.

EAU38440

NOTE: _____

- Air filter
 - This model's air filter is equipped with a disposable oil-coated paper element, which must not be cleaned with compressed air to avoid damaging it.
 - The air filter element needs to be replaced more frequently when riding in unusually wet or dusty areas.
 - Hydraulic brake and clutch systems
 - After disassembling the brake or clutch master cylinders, caliper cylinders or clutch release cylinder, always change the fluid. Regularly check the brake and clutch fluid levels and fill the reservoirs as required.
 - Replace the oil seals on the inner parts of the brake or clutch master cylinders, caliper cylinders and clutch release cylinder every two years.
 - Replace the brake and clutch hoses every four years or if cracked or damaged.
-

EAS20470

ENGINE

EAS20530

ADJUSTING THE VALVE CLEARANCE

The following procedure applies to all of the valves.

NOTE: _____

- The valve clearance is automatically adjusted by the hydraulic valve lifter. However, there are times when the valve clearance needs to be adjusted manually. If this is the case, adjust the clearance of the two maladjusted or worn valves using the adjusting screw on the rocker arm.

If clearance is on the slip side "1", loosen the adjusting screw and bring the valve clearance "a" within specification. Check if the valve clearance "b" on the adjusting screw "2" side is within specification.

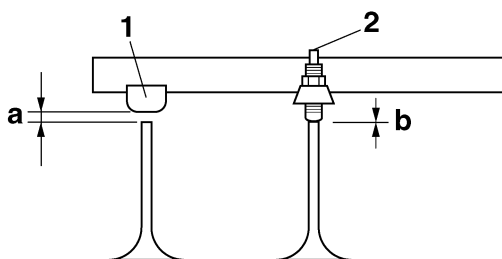

If clearance is on the adjusting screw "2" side, tighten the adjusting screw and bring the valve clearance "b" within specification.

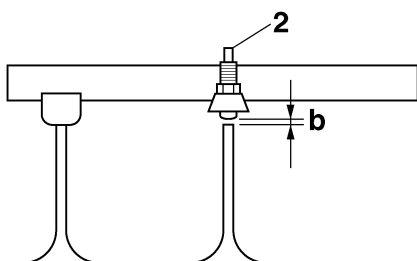

- Valve clearance adjustment should be made on a cold engine, at room temperature.
- When the valve clearance is to be measured or adjusted, the piston must be at top dead center (TDC) on the compression stroke.

1. Remove:

- Rider seat
 - Rider seat bracket assembly
- Refer to "GENERAL CHASSIS" on page 4-1.

- Fuel tank
- Refer to "FUEL TANK" on page 6-1.
- Air filter case
- Refer to "GENERAL CHASSIS" on page 4-1.
- Muffler
- Exhaust pipes
- Refer to "ENGINE REMOVAL" on page 5-1.

2. Disconnect:

- Spark plug caps

3. Remove:

- Spark plugs

4. Remove: (for XV19S(C)/ XV19M(C)/ XV19CTS(C)/ XV19CTM(C))

- Shift pedal assembly "1"

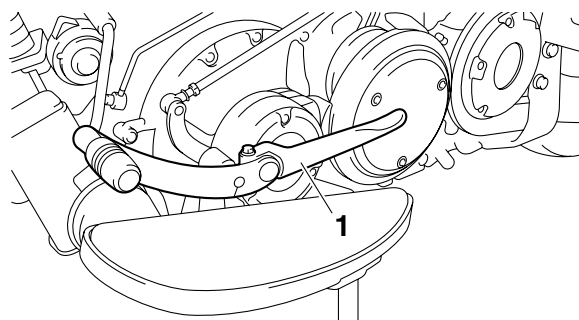

5. Remove:

- Damper cover "1"
- Damper "2"
- Timing mark accessing screw "3"
- Crankshaft end screw "4"

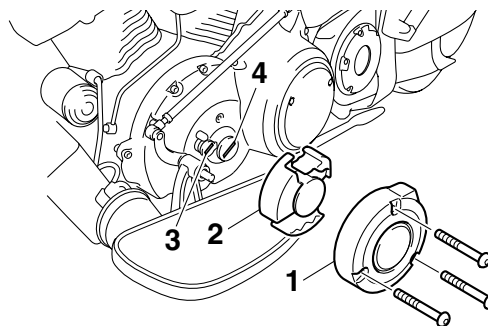

6. Remove:

- Camshaft sprocket cover "1"

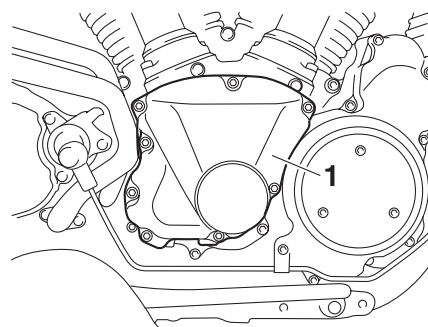

7. Remove:

- Wire harness guide bolt "1"

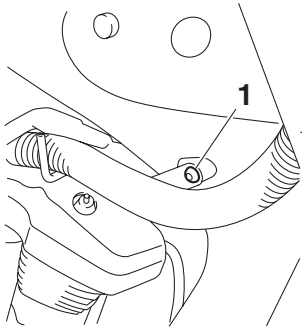

8. Remove:
 - Fuel tank damper “1”
 - Cylinder head breather hose “2”
9. Disconnect:
 - Oil tank breather hose “3”
 - Fuel outlet hose “4”

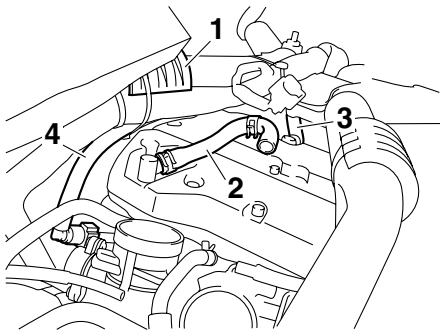

10. Remove:
 - Front cylinder head cover “1”
 - Rear cylinder head cover “2”

NOTE:

Due to the small clearance between the frame and the rear cylinder head cover, the three bolts “3” cannot be removed when the cover is in place. Loosen the bolts, and then remove the cylinder head cover from the right side of the vehicle, making sure that the bolts do not scratch the rocker arms or other engine parts.

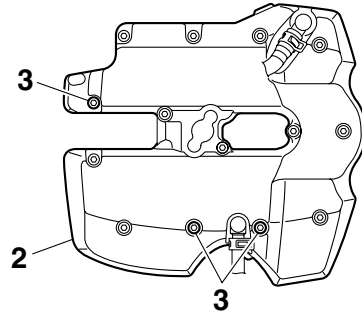
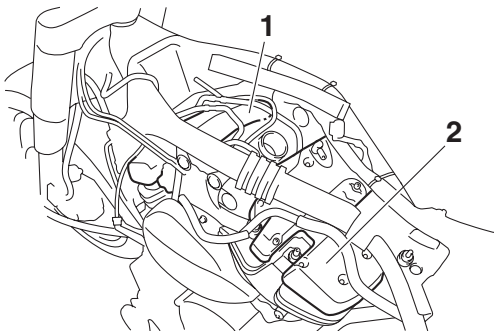

11. Measure:
 - Valve clearance
 Out of specification → Adjust.



Valve clearance (cold)

Intake

0.00–0.04 mm (0.0000–0.0016 in)

Exhaust

0.00–0.04 mm (0.0000–0.0016 in)



Piston #1 TDC (rear cylinder)

- a. Turn the crankshaft counterclockwise.

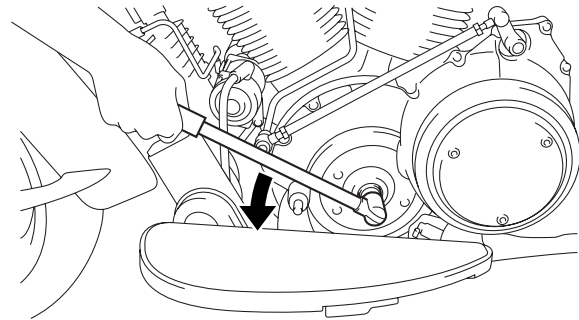

- b. When piston #1 is at TDC on the compression stroke, align the TDC mark “a” on the crankshaft position sensor rotor with the pointer “b” on the clutch cover.

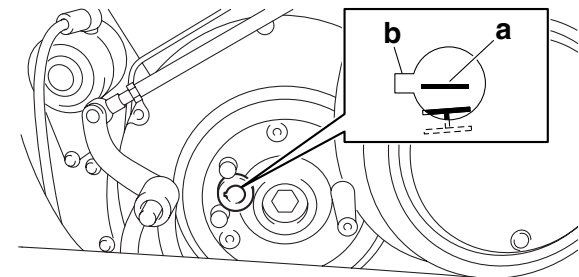

- c. Check the camshaft drive gear mark “c” position and camshaft driven gear mark “d” position as shown.
If the marks are not aligned, turn the crankshaft counterclockwise 360 degrees and recheck step (b).

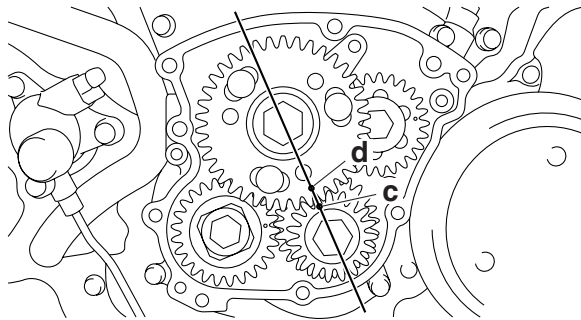

d. Measure the valve clearance with a thickness gauge.



Thickness gauge
90890-03180
Feeler gauge set
YU-26900-9



Piston #2 TDC (front cylinder)

- a. Turn the crankshaft counterclockwise from the piston #1 TDC by 408 degrees.
- b. When piston #2 is at TDC on the compression stroke, align the TDC mark "e" on the crankshaft position sensor rotor with the pointer "b" on the clutch cover.

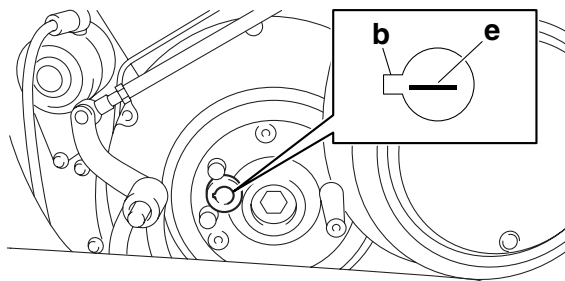

c. Check the camshaft drive gear mark "c" position and camshaft driven gear mark "d" position as shown.

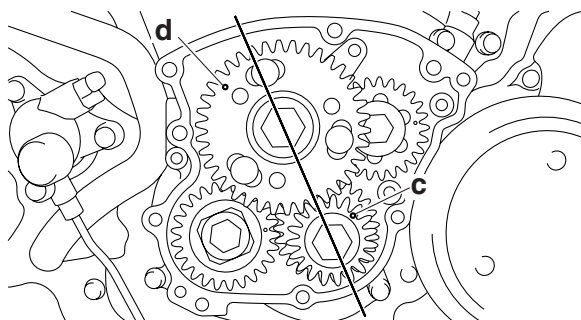

d. Measure the valve clearance with a thickness gauge.



Thickness gauge
90890-03180
Feeler gauge set
YU-26900-9



12. Adjust:

- Valve clearance



a. Loosen the locknut "1".

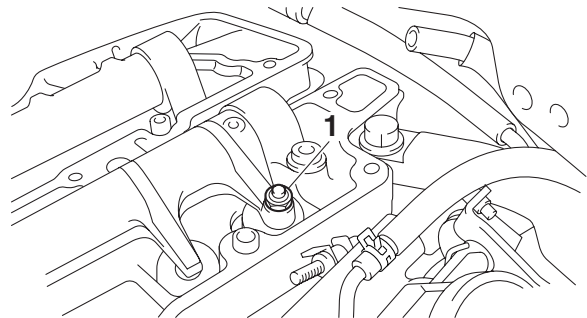

b. Insert a thickness gauge "2" between the end of the adjusting screw and the valve tip.



Thickness gauge
90890-03180
Feeler gauge set
YU-26900-9

c. Turn the adjusting screw "3" in direction "a" or "b" with the tappet adjusting tool "4" until the specified valve clearance is obtained.



Tappet adjusting tool (4 mm)
90890-04133
Six piece tappet set
YM-A5970

	Adjusting screw side	Slip side
Direction "a"	Valve clearance is increased.	Valve clearance is decreased.
Direction "b"	Valve clearance is decreased.	Valve clearance is increased.

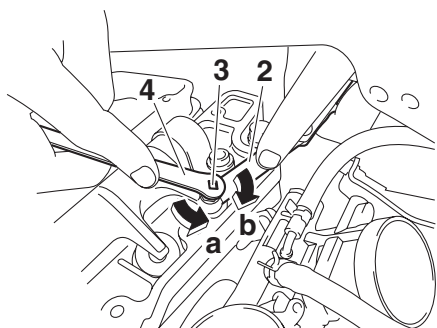

d. Hold the adjusting screw to prevent it from moving and tighten the locknut to specification.



Locknut (rocker arm adjusting screw)
20 Nm (2.0 m·kg, 14 ft·lb)



Tappet adjusting tool (4 mm)
90890-04133
Six piece tappet set
YM-A5970

- e. Measure the valve clearance again.
f. If the valve clearance is still out of specification, repeat all of the valve clearance adjustment steps until the specified clearance is obtained.



13. Install:

- All removed parts
Refer to "CAMSHAFTS" on page 5-17.

NOTE: _____

For installation, reverse the removal procedure.

EAS20570

SYNCHRONIZING THE THROTTLE BODIES

NOTE: _____

Prior to synchronizing the throttle bodies, the valve clearance and the engine idling speed should be properly adjusted and the ignition timing should be checked.

1. Stand the vehicle on a level surface.

NOTE: _____

Place the vehicle on a suitable stand.

2. Remove:

- Rider seat
- Rider seat bracket assembly
Refer to "GENERAL CHASSIS" on page 4-1.
- Cylinder-#1 ignition coil cover
Refer to "ENGINE REMOVAL" on page 5-1.

- Fuel tank
Refer to "FUEL TANK" on page 6-1.
3. Remove:
- Cylinder-#1 intake air pressure sensor bracket "1"
 - Cylinder-#2 intake air pressure sensor bracket "2"

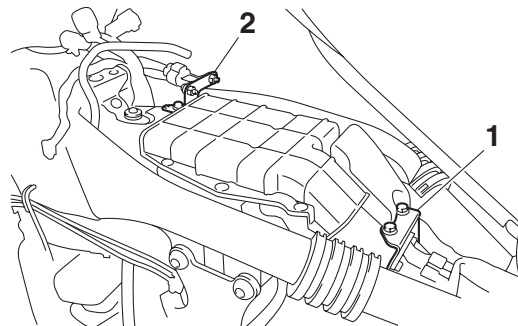

4. Disconnect:

- Cylinder-#1 intake air pressure sensor hose "1"
- Cylinder-#2 intake air pressure sensor hose "2"

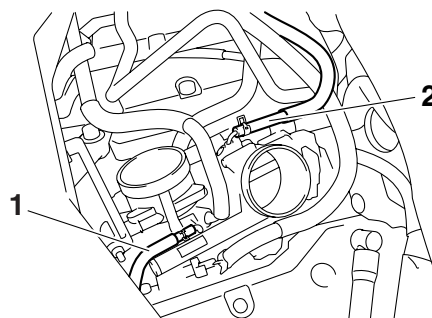

5. Install:

- Hose "1" (Parts No.: 5JW-24311-00)
- 3-way joint "2" (Parts No.: 90413-05014)
- Vacuum gauge hose for #1 "3"
- Vacuum gauge hose for #2 "4"
- Cylinder-#1 intake air pressure sensor hose "5"
- Cylinder-#2 intake air pressure sensor hose "6"
- Vacuum gauge
- Tachometer



Vacuum gauge
90890-03094
Carburetor synchronizer
YU-44456

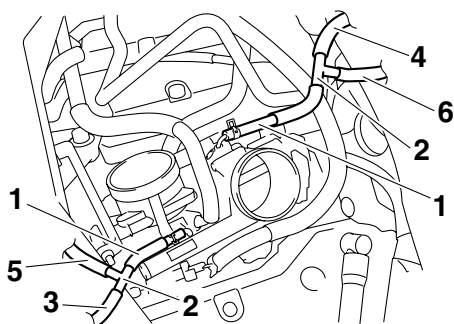

6. Install:
- Fuel tank
Refer to “FUEL TANK” on page 6-1.
7. Adjust:
- Throttle body synchronization

- a. Start the engine and let it warm up for several minutes, and then let it run at specified engine idling speed.

	Engine idling speed 850–950 r/min
--	---

- b. With throttle body #1 as standard, adjust throttle body #2 using the air screw “1” (for throttle body #2).

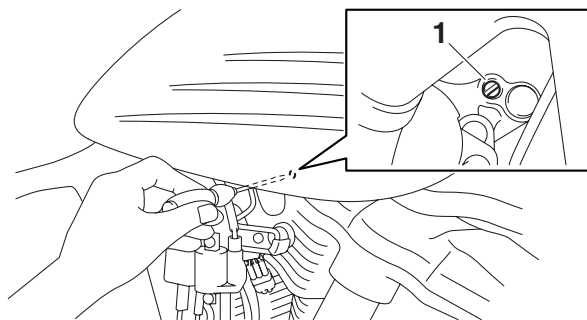

NOTE:

- After each step, rev the engine two or three times, each time for less than a second, and check the synchronization again.
- If the air screw was removed, turn the screw 3/4 turn in and be sure to synchronize the throttle body.

ECA14900

CAUTION:

Do not use the throttle valve adjusting screws to adjust the throttle body synchronization.

	Intake vacuum 31.3–35.3 kPa (9.2–10.4 inHg) (235–265 mmHg)
--	---

NOTE:

The difference in vacuum pressure between two throttle bodies should not exceed 1.33 kPa (10 mmHg).



8. Stop the engine and remove the measuring equipment.
9. Adjust:
- Throttle cable free play
Refer to “ADJUSTING THE THROTTLE CABLE FREE PLAY” on page 3-8.

	Throttle cable free play 4.0–6.0 mm (0.16–0.24 in)
--	--

10. Install:
- Fuel tank
Refer to “FUEL TANK” on page 6-1.
 - Cylinder-#1 ignition coil cover
Refer to “ENGINE REMOVAL” on page 5-1.
 - Rider seat bracket assembly
 - Rider seat
Refer to “GENERAL CHASSIS” on page 4-1.

EAS20630

ADJUSTING THE THROTTLE CABLE FREE PLAY

NOTE:

Prior to adjusting the throttle cable free play, the engine idling speed and throttle body synchronization should be adjusted properly.

1. Check:
- Throttle cable free play “a”
Out of specification → Adjust.

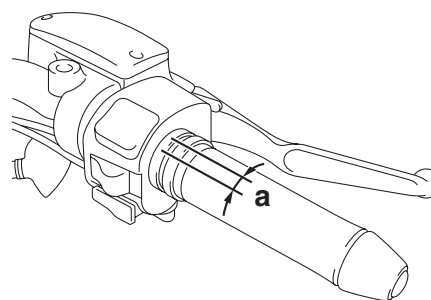

	Throttle cable free play 4.0–6.0 mm (0.16–0.24 in)
--	--

2. Adjust:
- Throttle cable free play



- a. Loosen the locknut “1”.

- b. Turn the adjusting nut “2” in direction “a” or “b” until the specified throttle cable free play is obtained.

Direction “a”
Throttle cable free play is increased.
Direction “b”
Throttle cable free play is decreased.

- c. Tighten the locknut “1”.

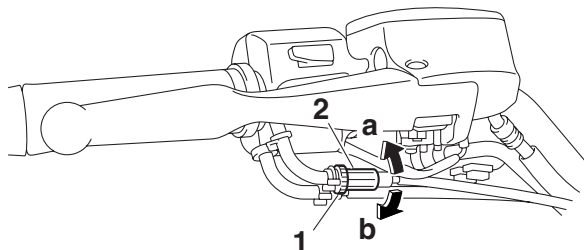

EWA12910

WARNING

After adjusting the throttle cable free play, start the engine and turn the handlebar to the right and to the left to ensure that this does not cause the engine idling speed to change.

EAS20680

CHECKING THE SPARK PLUGS

The following procedure applies to all of the spark plugs.

1. Remove:
 - Rider seat
 - Rider seat bracket assembly
Refer to “GENERAL CHASSIS” on page 4-1.
 - Fuel tank
Refer to “FUEL TANK” on page 6-1.
 - Air filter case
Refer to “GENERAL CHASSIS” on page 4-1.
2. Disconnect:
 - Spark plug cap
3. Remove:
 - Spark plug

ECA13320

CAUTION:

Before removing the spark plugs, blow away any dirt accumulated in the spark plug wells with compressed air to prevent it from falling into the cylinders.

4. Check:
- Spark plug type
Incorrect → Change.



Manufacturer/model
NGK/DPR8EA-9
Manufacturer/model
DENSO/X24EPR-U9

5. Check:
 - Electrode “1”
Damage/wear → Replace the spark plug.
 - Insulator “2”
Abnormal color → Replace the spark plug.
Normal color is medium-to-light tan.
6. Clean:
 - Spark plug
(with a spark plug cleaner or wire brush)
7. Measure:
 - Spark plug gap “a”
(with a wire thickness gauge)
Out of specification → Regap.



Spark plug gap
0.8–0.9 mm (0.031–0.035 in)

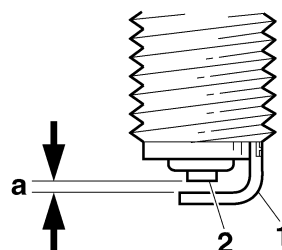

8. Install:
 - Spark plug



Spark plug
18 Nm (1.8 m·kg, 13 ft·lb)

NOTE: Before installing the spark plug, clean the spark plug and gasket surface.

9. Connect:
 - Spark plug cap
10. Install:
 - Air filter case
Refer to “GENERAL CHASSIS” on page 4-1.
 - Fuel tank
Refer to “FUEL TANK” on page 6-1.
 - Rider seat bracket assembly
 - Rider seat
Refer to “GENERAL CHASSIS” on page 4-1.

EAS20700

CHECKING THE IGNITION TIMING

NOTE:

Prior to checking the ignition timing, check the wiring connections of the entire ignition system. Make sure all connections are tight and free of corrosion.

1. Stand the vehicle on a level surface.
2. Remove: (for XV19S(C)/ XV19M(C)/ XV19CTS(C)/ XV19CTM(C))
 - Shift pedal assembly “1”

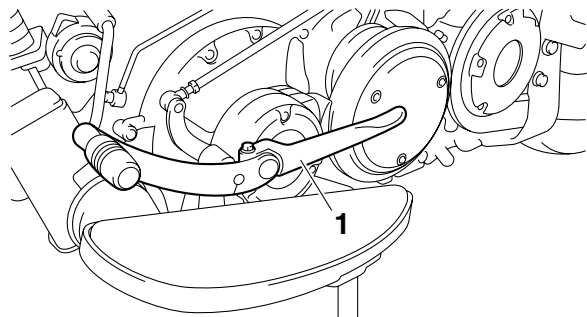

3. Remove:
 - Damper cover “1”
 - Damper “2”
 - Timing mark accessing screw “3”

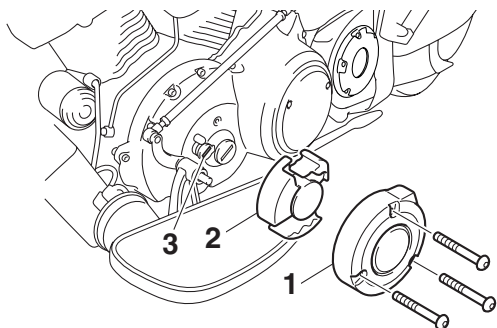

4. Connect:
 - Timing light “1”
 - Tachometer



Timing light
90890-03141
Inductive clamp timing light
YU-03141

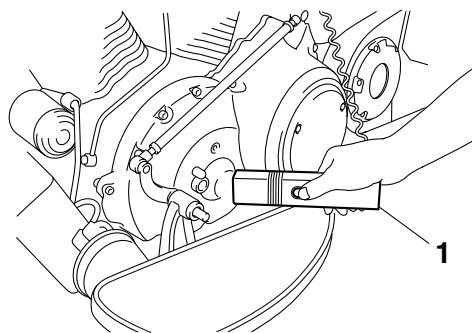

5. Check:
 - Ignition timing

- a. Start the engine, warm it up for several minutes, and then let it run at the specified engine idling speed.



Engine idling speed
850–950 r/min

- b. Check that pointer “a” on the clutch cover is within the firing range “b” on the crankshaft position sensor rotor. Incorrect firing range → Check the ignition system.

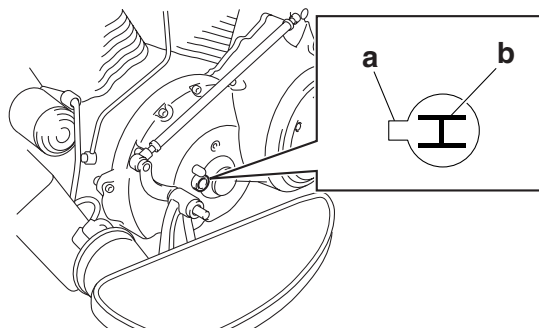

NOTE:

The ignition timing is not adjustable.

6. Install:
 - Timing mark accessing screw
 - Damper
 - Damper cover



Damper cover bolt
10 Nm (1.0 m·kg, 7.2 ft·lb)

7. Install: (for XV19S(C)/ XV19M(C)/ XV19CTS(C)/ XV19CTM(C))
 - Shift pedal assembly “1”



Shift pedal bolt
18 Nm (1.8 m·kg, 13 ft·lb)

NOTE:

Align the mark “a” on the shift pedal shaft with the slot in the shift pedal.

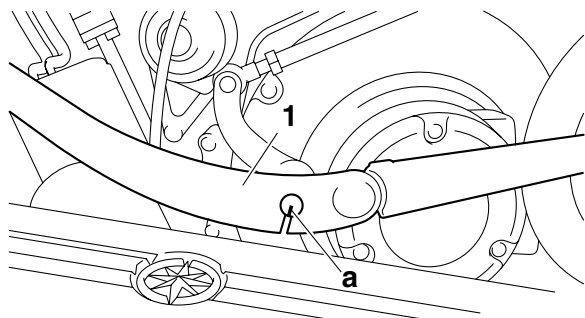

EAS20750

CHECKING THE ENGINE OIL LEVEL

1. Stand the vehicle on a level surface.

NOTE:

- Place the vehicle on a suitable stand.
 - Make sure the vehicle is upright.
2. Start the engine, warm it up for approximately 15 minutes until the oil temperature rises to 60 °C (140 °F), and then turn it off.
3. Remove:
- Rider seat
Refer to “GENERAL CHASSIS” on page 4-1.
4. Remove:
- Dipstick “1”
5. Check:
- Engine oil level
The engine oil level should be between the minimum level mark “a” and maximum level mark “b”.
Below the minimum level mark → Add the recommended engine oil to the proper level.

NOTE:

- Before checking the engine oil level, wait a few minutes until the oil has settled.
- Do not screw the dipstick in when inspecting the oil level.

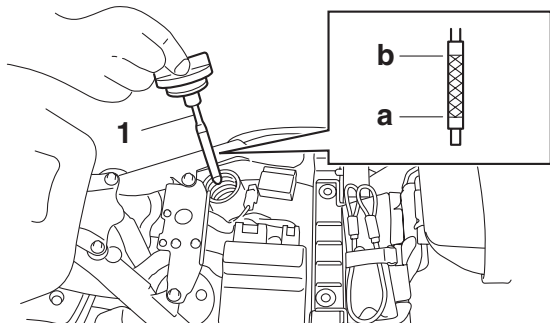

Type
**YAMALUBE 4 (20W40) or
SAE20W40**
Recommended engine oil grade
**API service SG type or higher,
JASO standard MA**

ECA13380

CAUTION:

- Engine oil also lubricates the clutch and the wrong oil types or additives could cause clutch slippage. Therefore, do not add any chemical additives.
- Do not allow foreign materials to enter the crankcase.

6. Start the engine, warm it up for several minutes, and then turn it off.
7. Check the engine oil level again.

NOTE:

Before checking the engine oil level, wait a few minutes until the oil has settled.

8. Install:
- Dipstick
9. Install:
- Rider seat
Refer to “GENERAL CHASSIS” on page 4-1.

EAS20780

CHANGING THE ENGINE OIL

1. Start the engine, warm it up for several minutes, and then turn it off.
2. Place a container under the engine oil drain bolts.
3. Remove:
- Engine oil filler cap “1”

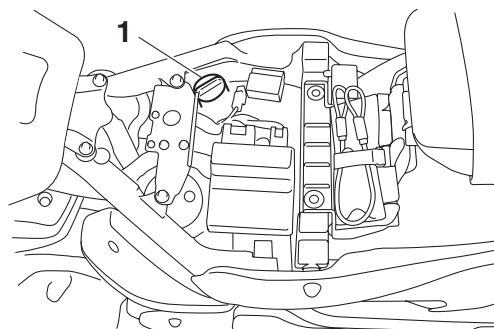

4. Remove:
- Engine oil drain bolt (oil tank) “1”
(along with the gasket)

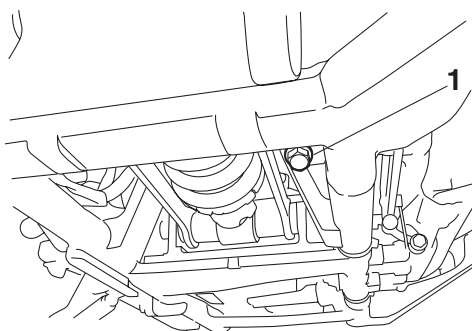

5. Remove:
- Engine oil drain bolts (crankcase) "1" (along with the gaskets)

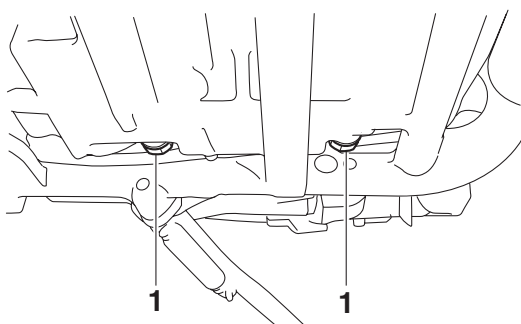

6. Drain:
- Engine oil (completely from the oil tank and crankcase)
7. If the oil filter cartridge is also to be replaced, perform the following procedure.

- a. Remove the oil filter cartridge "1" with an oil filter wrench "2".



Oil filter wrench
90890-01426
YU-38411

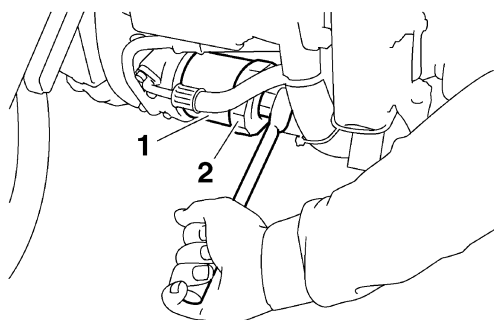

- b. Lubricate the O-ring "3" of the new oil filter cartridge with a thin coat of engine oil.

ECA13390

CAUTION:

Make sure the O-ring "3" is positioned correctly in the groove of the oil filter cartridge.

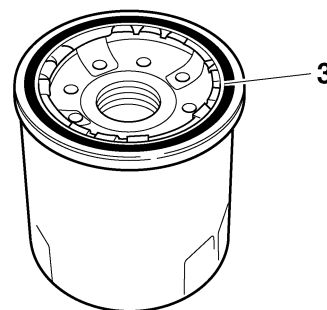

- c. Tighten the new oil filter cartridge to specification with an oil filter wrench.



Oil filter cartridge
17 Nm (1.7 m·kg, 12 ft·lb)

8. Check:
- Engine oil drain bolt gaskets
Damage → Replace.
9. Install:
- Engine oil drain bolt (oil tank)
(along with the gasket)



Engine oil drain bolt (oil tank)
43 Nm (4.3 m·kg, 31 ft·lb)

10. Install:
- Engine oil drain bolts (crankcase)
(along with the gaskets)



Engine oil drain bolt (crankcase)
43 Nm (4.3 m·kg, 31 ft·lb)

11. Fill:
- Oil tank
(with the specified amount of the recommended engine oil)



Engine oil quantity

Total amount
5.20 L (5.50 US qt) (4.58 Imp. qt)

Without oil filter cartridge replacement
4.10 L (4.33 US qt) (3.61 Imp. qt)

With oil filter cartridge replacement
4.90 L (5.18 US qt) (4.31 Imp. qt)

NOTE:

Pour the engine oil in two stages. First, pour in 2.5 L of oil, then start the engine and rev it 3 to 5 times. Stop the engine, and then pour in the remainder of the specified amount.

EC1D71008

CAUTION: _____

When starting the engine make sure the dipstick is securely fitted into the oil tank.

12.Fill: (when engine is disassembled)

- Crankcase and oil tank
(with the specified amount of the recommended engine oil)



Engine oil quantity

Total amount

5.20 L (5.50 US qt) (4.58 Imp.qt)

Engine

3.2 L (3.38 US qt) (2.82 Imp.qt)

Oil tank

2.0 L (2.11 US qt) (1.76 Imp.qt)

13.Install:

- Engine oil filler cap

14.Start the engine, warm it up for several minutes, and then turn it off.

15.Check:

- Engine
(for engine oil leaks)

16.Check:

- Engine oil level
Refer to "CHECKING THE ENGINE OIL LEVEL" on page 3-11.

17.Check:

- Engine oil pressure

a. Slightly loosen the oil gallery bolts "1".

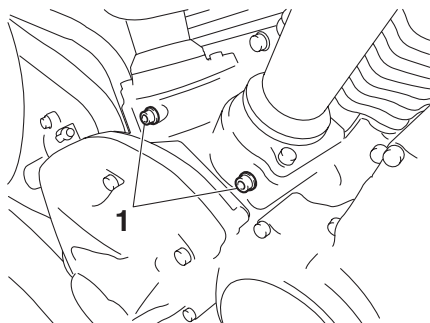

b. Start the engine and keep it idling until engine oil starts to seep from the oil gallery bolts. If no engine oil comes out after one minute, turn the engine off so that it will not seize.

c. Check the engine oil passages, the oil filter cartridge and the oil pump for damage or leakage. Refer to "OIL PUMP" on page 5-100.

d. Start the engine after solving the problem(s) and check the engine oil pressure again.

e. Tighten the oil gallery bolts to specification.



Oil gallery bolt

**XV19S(C)/ XV19M(C)/
XV19CTS(C)/ XV19CTM(C):
10 Nm (1.0 m·kg, 7.2 ft·lb)
XV19CS(C)/ XV19C(C):
8 Nm (0.8 m·kg, 5.8 ft·lb)**

EAS20840

CHECKING THE TRANSFER GEAR OIL LEVEL

1. Stand the vehicle on a level surface.

NOTE: _____

- Place the vehicle on a suitable stand.
- Make sure the vehicle is upright.

2. Remove:

- Transfer gear oil check bolt "1"

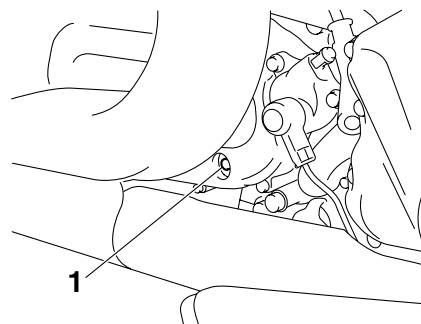

3. Check:

- Transfer gear oil level
The transfer gear oil level should be up to the brim "1" of the hole.
Below the brim → Add the recommended transfer gear oil to the proper level.

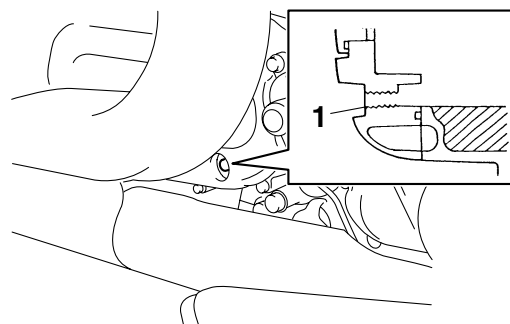

Type
SAE80 API GL-4 Hypoid gear oil

EC1D71024

CAUTION: _____

Do not allow foreign materials to enter the transfer gear case.

4. Install:
 - Transfer gear oil check bolt



Transfer gear oil check bolt
8 Nm (0.8 m·kg, 5.8 ft·lb)

EAS20850

CHANGING THE TRANSFER GEAR OIL

1. Remove:
 - Muffler
 - Exhaust pipes
 Refer to “ENGINE REMOVAL” on page 5-1.
2. Place a container under the transfer gear oil drain bolt.
3. Remove:
 - Straight plug “1”
 - Transfer gear oil drain bolt “2”

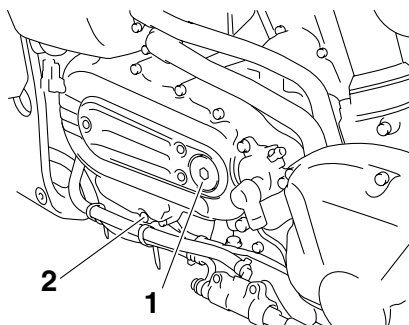

4. Drain:
 - Transfer gear oil (completely from the transfer gear case)
5. Check:
 - Transfer gear oil drain bolt gasket
 Damage → Replace.
6. Install:
 - Transfer gear oil drain bolt (along with the gasket)



Transfer gear oil drain bolt
18 Nm (1.8 m·kg, 13 ft·lb)

7. Fill:
 - Transfer gear case (with the specified amount of the recommended transfer gear oil)



Quantity
0.55 L (0.58 US qt) (0.48 Imp.qt)
Quantity (disassembled)
0.60 L (0.63 US qt) (0.53 Imp.qt)

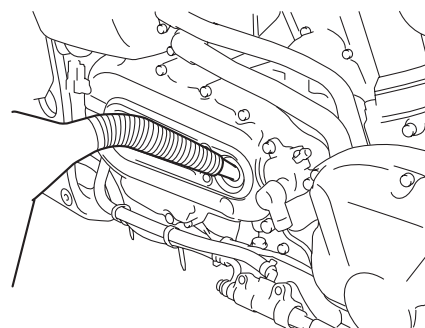

8. Install:
 - Straight plug
9. Check:
 - Transfer gear oil level
 Refer to “CHECKING THE TRANSFER GEAR OIL LEVEL” on page 3-13.
10. Install:
 - Exhaust pipes
 - Muffler
 Refer to “ENGINE REMOVAL” on page 5-1.

EAS20890

CHECKING THE CLUTCH FLUID LEVEL

1. Stand the vehicle on a level surface.

NOTE:

Place the vehicle on a suitable stand.

2. Check:
 - Clutch fluid level
 Below the minimum level mark “a” → Add the recommended clutch fluid to the proper level.



Recommended clutch fluid
Brake fluid DOT 4

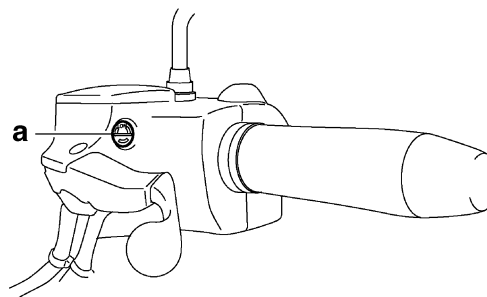

EWA13370

WARNING

- Use only the designated clutch fluid. Other clutch fluids may cause the rubber seals to deteriorate, causing leakage and poor clutch performance.
- Refill with the same type of clutch fluid that is already in the system. Mixing clutch fluids may result in a harmful chemical reaction, leading to poor clutch performance.

- When refilling, be careful that water does not enter the clutch fluid reservoir. Water will significantly lower the boiling point of the clutch fluid and could cause vapor lock.

ECA13420

CAUTION:

Clutch fluid may damage painted surfaces or plastic parts. Therefore, always clean up any spill clutch fluid immediately.

NOTE:

In order to ensure a correct reading of the clutch fluid level, make sure the top of the reservoir is horizontal.

EAS20900

BLEEDING THE HYDRAULIC CLUTCH SYSTEM

EWA13000

WARNING

Bleed the hydraulic clutch system whenever:

- the system was disassembled,
- a clutch hose was loosened or removed,
- the clutch fluid level is very low,
- clutch operation is faulty.

NOTE:

- Be careful not to spill any clutch fluid or allow the clutch master cylinder reservoir to overflow.
- When bleeding the hydraulic clutch system, make sure there is always enough clutch fluid before applying the clutch lever. Ignoring this precaution could allow air to enter the hydraulic clutch system, considerably lengthening the bleeding procedure.
- If bleeding is difficult, it may be necessary to let the clutch fluid settle for a few hours. Repeat the bleeding procedure when the tiny bubbles in the hose have disappeared.

1. Bleed:

- Hydraulic clutch system



- Add the recommended clutch fluid to the proper level.
- Install the clutch master cylinder reservoir diaphragm.
- Connect a clear plastic hose “1” tightly to the bleed screw “2”.

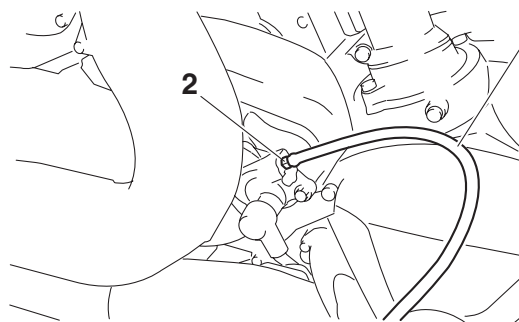

- Place the other end of the hose into a container.
- Slowly squeeze the clutch lever several times.
- Fully squeeze the clutch lever without releasing it.
- Loosen the bleed screw. This will release the tension and cause the clutch lever to contact the handlebar grip.
- Tighten the bleed screw and then release the clutch lever.
- Repeat steps (e) to (h) until all of the air bubbles have disappeared from the clutch fluid in the plastic hose.
- Tighten the bleed screw to specification.



Bleed screw (clutch release cylinder)
6 Nm (0.6 m·kg, 4.3 ft·lb)

- Add the recommended clutch fluid to the proper level.
Refer to “CHECKING THE CLUTCH FLUID LEVEL” on page 3-14.

EWA13010

WARNING

After bleeding the hydraulic clutch system, check the clutch operation.



EAS20960

REPLACING THE AIR FILTER ELEMENT

- Remove:
 - Rider seat
Refer to “GENERAL CHASSIS” on page 4-1.
- Remove:
 - Fuel tank
Refer to “FUEL TANK” on page 6-1.
- Remove:
 - Air filter case cover “1”

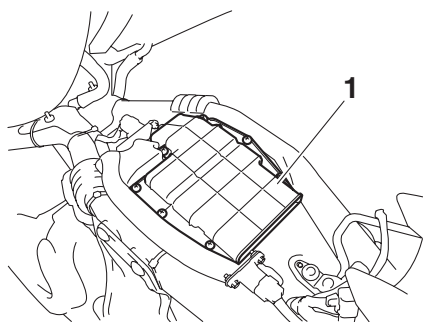

4. Remove:
- Air filter element “1”

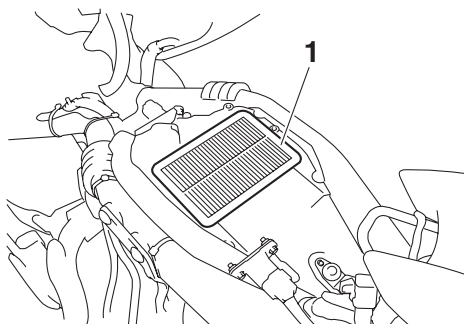

5. Check:
- Air filter element
Damage → Replace.

NOTE: _____

The air filter needs more frequent service if you are riding in unusually wet or dusty areas.

6. Install:
- Air filter case cover

EC1D71002

CAUTION: _____

Never operate the engine without the air filter element installed. Unfiltered air will cause rapid wear of engine parts and may damage the engine. Operating the engine without the air filter element will also affect the throttle body synchronization, leading to poor engine performance and possible overheating.

NOTE: _____

When installing the air filter element into the air filter case, make sure that the sealing surfaces are aligned to prevent any air leaks.

7. Install:
- Fuel tank
Refer to “FUEL TANK” on page 6-1.
 - Rider seat
Refer to “GENERAL CHASSIS” on page 4-1.

EAS21010

CHECKING THE THROTTLE BODY JOINTS

The following procedure applies to all of the throttle body joints and intake manifolds.

1. Remove:
 - Rider seat
 - Rider seat bracket assembly
Refer to “GENERAL CHASSIS” on page 4-1.
 - Fuel tank
Refer to “FUEL TANK” on page 6-1.
 - Air filter case
Refer to “GENERAL CHASSIS” on page 4-1.
2. Check:
 - Throttle body joints “1”
Cracks/damage → Replace.

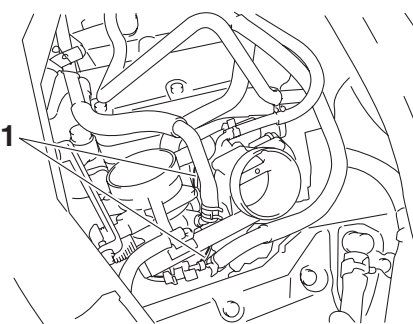

3. Install:
 - Air filter case
Refer to “GENERAL CHASSIS” on page 4-1.
 - Fuel tank
Refer to “FUEL TANK” on page 6-1.
 - Rider seat bracket assembly
 - Rider seat
Refer to “GENERAL CHASSIS” on page 4-1.

EAS21030

CHECKING THE FUEL LINE

The following procedure applies to all of the fuel, air vent and breather hoses.

1. Remove:
 - Rider seat
 - Rider seat bracket assembly
Refer to “GENERAL CHASSIS” on page 4-1.
 - Fuel tank
Refer to “FUEL TANK” on page 6-1.
2. Check:
 - Fuel hoses “1”
 - Air vent hose “2”
 - Breather hose “3”
Cracks/damage → Replace.
Loose connection → Connect properly.

ECA14940

CAUTION: _____

Make sure the fuel tank breather hose is routed correctly.

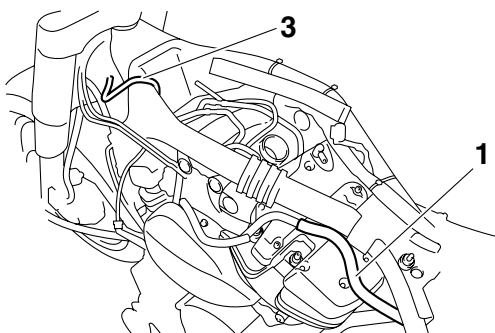

3. Install:
 - Fuel tank
Refer to "FUEL TANK" on page 6-1.
 - Rider seat bracket assembly
 - Rider seat
Refer to "GENERAL CHASSIS" on page 4-1.

EAS21050

CHECKING THE CYLINDER HEAD BREATHER HOSE

1. Remove:
 - Rider seat
 - Rider seat bracket assembly
Refer to "GENERAL CHASSIS" on page 4-1.
 - Fuel tank
Refer to "FUEL TANK" on page 6-1.
 - Air filter case
Refer to "GENERAL CHASSIS" on page 4-1.
2. Check:
 - Cylinder head breather hose "1"
Cracks/damage → Replace.
Loose connection → Connect properly.

ECA14920

CAUTION:

Make sure the cylinder head breather hose is routed correctly.

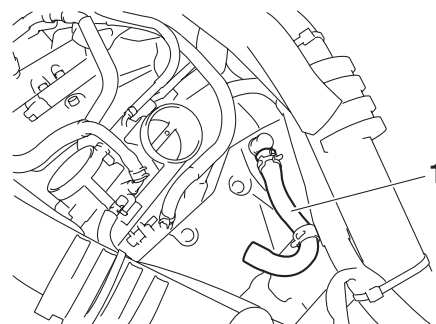

3. Install:
 - Air filter case
Refer to "GENERAL CHASSIS" on page 4-1.
 - Fuel tank
Refer to "FUEL TANK" on page 6-1.
 - Rider seat bracket assembly
 - Rider seat
Refer to "GENERAL CHASSIS" on page 4-1.

EAS21060

CHECKING THE OIL TANK BREATHER HOSE

1. Remove:
 - Right side cover
Refer to "GENERAL CHASSIS" on page 4-1.
2. Check:
 - Oil tank breather hose "1"
Cracks/damage → Replace.
Loose connection → Connect properly.

ECA14930

CAUTION:

Make sure the oil tank breather hose is routed correctly.

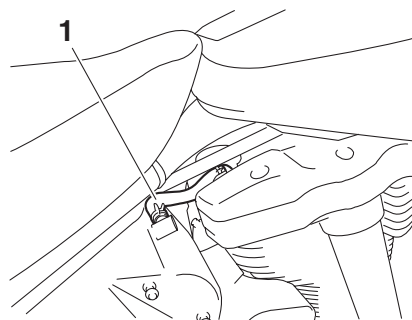

3. Install:
 - Right side cover
Refer to "GENERAL CHASSIS" on page 4-1.

EAS21080

CHECKING THE EXHAUST SYSTEM (for XV19S(C)/ XV19M(C)/ XV19CTS(C)/ XV19CTM(C))

The following procedure applies to all of the exhaust pipes and gaskets.

1. Check:

- Front exhaust pipe “1”
- Rear exhaust pipe “2”
- Muffler “3”
- Muffler bracket “4”
Cracks/damage → Replace.
- Gaskets “5”
Exhaust gas leaks → Replace.

2. Check:

- Tightening torque
- Front exhaust pipe nuts “6”
 - Front exhaust pipe and rear exhaust pipe bolt “7”
 - Rear exhaust pipe nuts “8”
 - Rear exhaust pipe and muffler bolt “9”
 - Muffler and muffler bracket bolts “10”
 - Muffler bracket and frame bolts “11”



Front exhaust pipe nut
20 Nm (2.0 m·kg, 14 ft·lb)
Front exhaust pipe and rear exhaust pipe bolt
20 Nm (2.0 m·kg, 14 ft·lb)
Rear exhaust pipe nut
24 Nm (2.4 m·kg, 17 ft·lb)
Rear exhaust pipe and muffler bolt
20 Nm (2.0 m·kg, 14 ft·lb)
Muffler and muffler bracket bolt
29 Nm (2.9 m·kg, 21 ft·lb)
Muffler bracket and frame bolt
53 Nm (5.3 m·kg, 38 ft·lb)
LOCTITE®

EAS1D77002

CHECKING THE EXHAUST SYSTEM (for XV19CS(C)/ XV19C(C))

The following procedure applies to all of the exhaust pipes and gaskets.

1. Check:

- Front exhaust pipe “1”
- Rear exhaust pipe “2”
- Muffler “3”
- Muffler bracket “4”
Cracks/damage → Replace.
- Gaskets “5”
Exhaust gas leaks → Replace.

2. Check:

- Tightening torque
- Front exhaust pipe nuts “6”
 - Front exhaust pipe and rear exhaust pipe bolt “7”
 - Rear exhaust pipe nuts “8”
 - Rear exhaust pipe and muffler bolt “9”
 - Muffler and muffler bracket bolts “10”
 - Muffler bracket and frame bolts “11”
 - Muffler and frame bolt “12”



Front exhaust pipe nut
20 Nm (2.0 m·kg, 14 ft·lb)
Front exhaust pipe and rear exhaust pipe bolt
20 Nm (2.0 m·kg, 14 ft·lb)
Rear exhaust pipe nut
24 Nm (2.4 m·kg, 17 ft·lb)
Rear exhaust pipe and muffler bolt
20 Nm (2.0 m·kg, 14 ft·lb)
Muffler and muffler bracket bolt
29 Nm (2.9 m·kg, 21 ft·lb)
Muffler bracket and frame bolt
53 Nm (5.3 m·kg, 38 ft·lb)
LOCTITE®
Muffler and frame bolt
20 Nm (2.0 m·kg, 14 ft·lb)

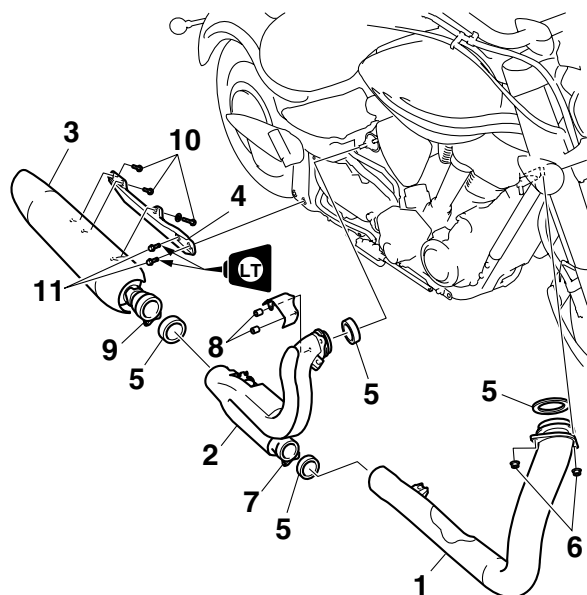

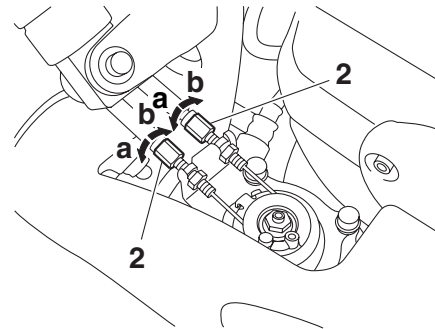
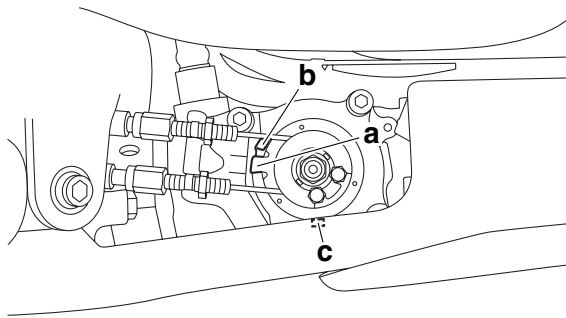

3. Check:

- EXUP cable free play (at the EXUP valve pulley) “a” and “b”



EXUP cable free play (at the EXUP valve pulley)

- a: 3 mm (0.12 in) or less**
- b: 3 mm (0.12 in) or less**

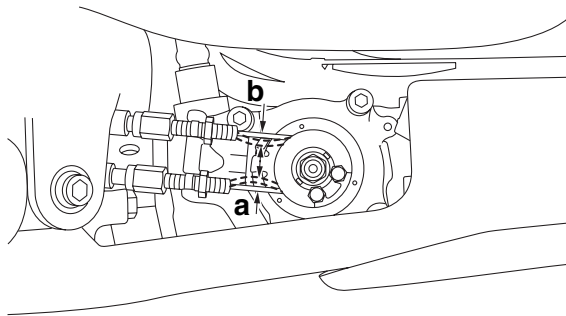

4. Adjust:

- EXUP cable free play



- a. Loosen both locknuts “1”.

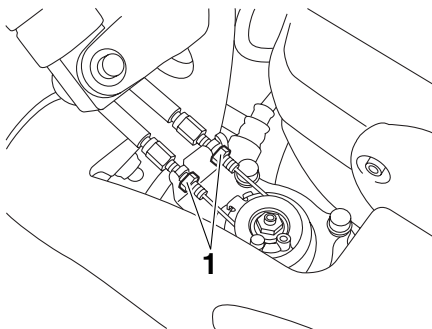

- b. Turn both adjusting bolts “2” in or out until the specification.

Turn in “a” →
Free play is increased.
 Turn out “b” →
Free play is decreased.

- c. Tighten both locknuts.

- d. Turn the main switch to “ON” and check that the projection “c” on the EXUP valve pulley contacts the stoppers (fully open and fully closed positions), then stops between the lines “d” on the cable holder.

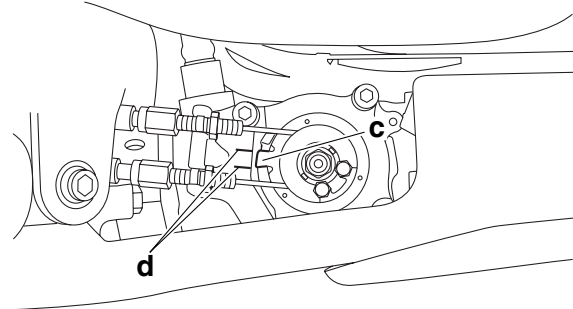

5. Install:

- EXUP valve pulley cover

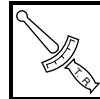

EXUP valve pulley cover bolt
7 Nm (0.7 m·kg, 5.1 ft·lb)

EAS21140

CHASSIS

EAS21190

ADJUSTING THE REAR DISC BRAKE

1. Check:

- Brake pedal position
(distance "a" from the top of the rider footrest to the top of the brake pedal)
Out of specification → Adjust.

	<p>Brake pedal position XV19S(C)/ XV19M(C)/ XV19CTS(C)/ XV19CTM(C): 110.0 mm (4.33 in) XV19CS(C)/ XV19C(C): 93.0 mm (3.66 in)</p>
---	--

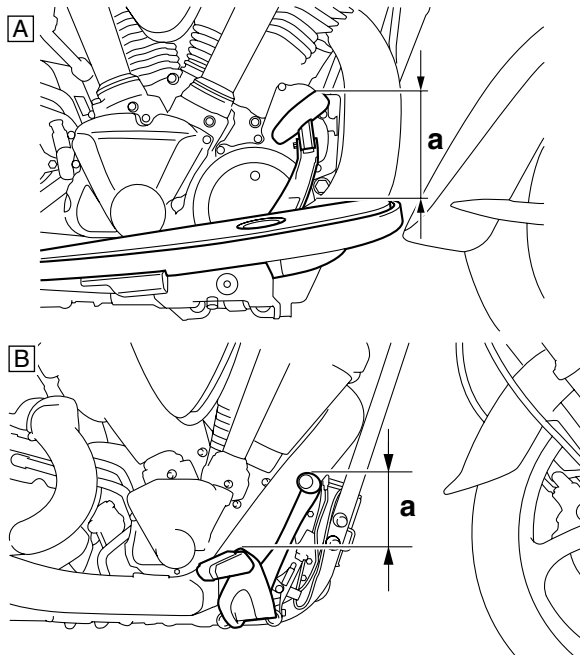

- For XV19S(C)/ XV19M(C)/ XV19CTS(C)/ XV19CTM(C)
- For XV19CS(C)/ XV19C(C)

2. Adjust:

- Brake pedal position

- Loosen the locknut "1".
- Turn the adjusting bolt "2" in direction "a" or "b" until the specified brake pedal position is obtained.

<p>Direction "a" Brake pedal is raised. Direction "b" Brake pedal is lowered.</p>
--

EWA13070

WARNING

After adjusting the brake pedal position, check that the end of the adjusting bolt "c" is visible through the hole "d".

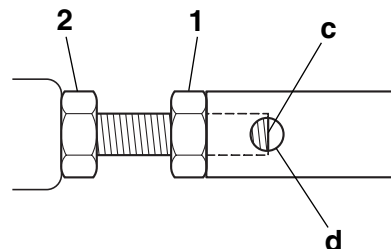
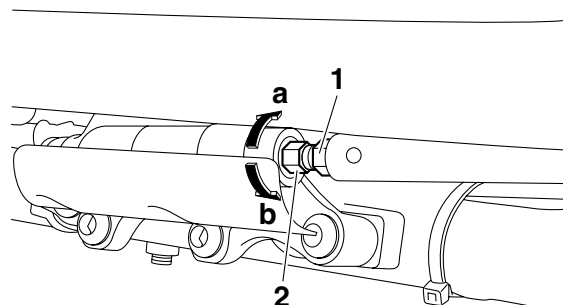

c. Tighten the locknut.

EW1D71005

WARNING

A soft or spongy feeling in the brake pedal can indicate the presence of air in the brake system. Before the vehicle is operated, the air must be removed by bleeding the brake system. Air in the brake system will considerably reduce braking performance.

ECA13510

CAUTION:

After adjusting the brake pedal position, make sure there is no brake drag.



3. Adjust:

- Rear brake light switch
Refer to "ADJUSTING THE REAR BRAKE LIGHT SWITCH" on page 3-23.

EAS21240

CHECKING THE BRAKE FLUID LEVEL

- Stand the vehicle on a level surface.

NOTE:

- Place the vehicle on a suitable stand.
- Make sure the vehicle is upright.

2. Remove:
 - Rider seat
Refer to “GENERAL CHASSIS” on page 4-1.
3. Check:
 - Brake fluid level
Below the minimum level mark “a” → Add the recommended brake fluid to the proper level.

	Front brake Recommended fluid DOT 4
	Rear brake Recommended fluid DOT 4

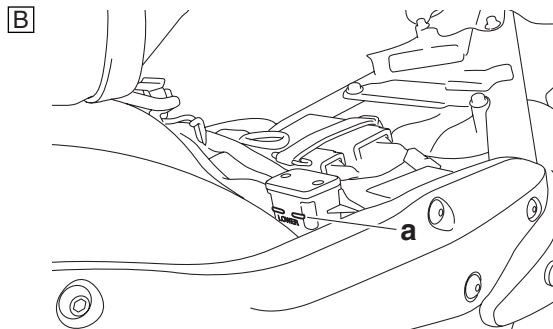
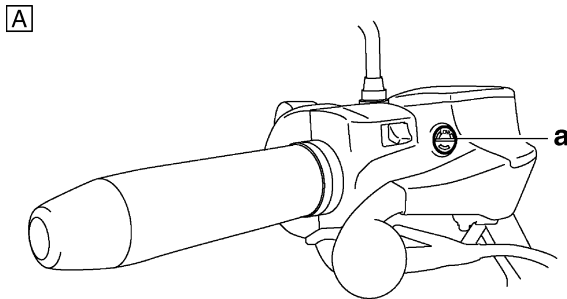

- A. Front brake
B. Rear brake

EWA13090

WARNING

- Use only the designated brake fluid. Other brake fluids may cause the rubber seals to deteriorate, causing leakage and poor brake performance.
- Refill with the same type of brake fluid that is already in the system. Mixing brake fluids may result in a harmful chemical reaction, leading to poor brake performance.
- When refilling, be careful that water does not enter the brake fluid reservoir. Water will significantly lower the boiling point of the brake fluid and could cause vapor lock.

ECA13540

CAUTION:

Brake fluid may damage painted surfaces and plastic parts. Therefore, always clean up any spilled brake fluid immediately.

NOTE:

In order to ensure a correct reading of the brake fluid level, make sure the top of the brake fluid reservoir is horizontal.

4. Install:
 - Rider seat
Refer to “GENERAL CHASSIS” on page 4-1.

EAS21250

CHECKING THE FRONT BRAKE PADS

The following procedure applies to all of the brake pads.

1. Operate the brake.
2. Check:
 - Front brake pad
Wear indicator grooves “1” almost disappeared → Replace the brake pads as a set. Refer to “FRONT BRAKE” on page 4-35.

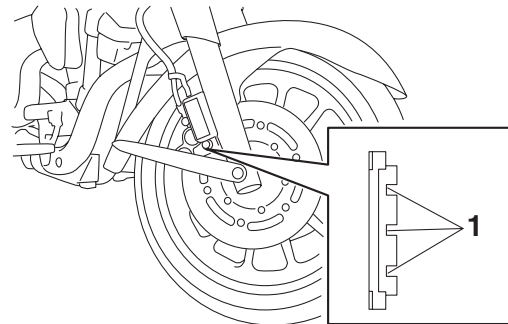

EAS21260

CHECKING THE REAR BRAKE PADS

The following procedure applies to all of the brake pads.

1. Operate the brake.
2. Check:
 - Rear brake pad
Wear indicators “1” almost touch the brake disc → Replace the brake pads as a set. Refer to “REAR BRAKE” on page 4-47.

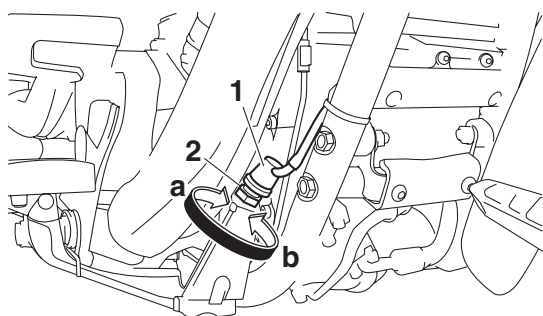

EAS21350

BLEEDING THE HYDRAULIC BRAKE SYSTEM

EWA13100

WARNING

Bleed the hydraulic brake system whenever:

- the system is disassembled.
- a brake hose is loosened, disconnected or replaced.
- the brake fluid level is very low.
- brake operation is faulty.

1. Remove:
 - Rider seat
 Refer to “GENERAL CHASSIS” on page 4-1.

NOTE:

- Be careful not to spill any brake fluid or allow the brake master cylinder reservoir or brake fluid reservoir to overflow.
- When bleeding the hydraulic brake system, make sure there is always enough brake fluid before applying the brake. Ignoring this precaution could allow air to enter the hydraulic brake system, considerably lengthening the bleeding procedure.
- If bleeding is difficult, it may be necessary to let the brake fluid settle for a few hours. Repeat the bleeding procedure when the tiny bubbles in the hose have disappeared.

2. Bleed:
 - Hydraulic brake system



- a. Fill the brake fluid reservoir to the proper level with the recommended brake fluid.
- b. Install the diaphragm (brake master cylinder reservoir or brake fluid reservoir).
- c. Connect a clear plastic hose “1” tightly to the bleed screw “2”.

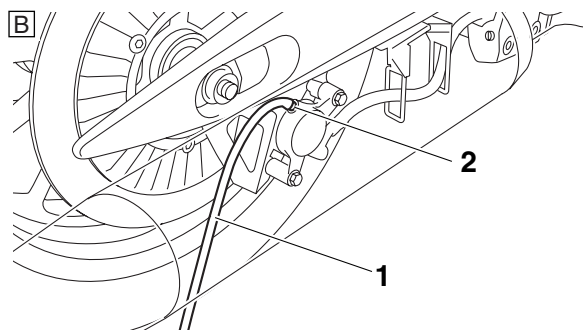
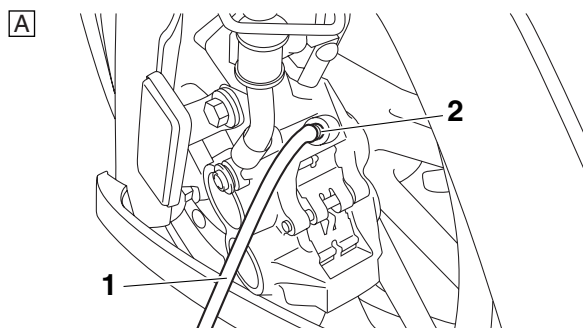

- A. Front
B. Rear

- d. Place the other end of the hose into a container.
- e. Slowly apply the brake several times.
- f. Fully pull the brake lever or fully press down the brake pedal and hold it in position.
- g. Loosen the bleed screw.

NOTE:

Loosening the bleed screw will release the pressure and cause the brake lever to contact the throttle grip or the brake pedal to fully extend.

- h. Tighten the bleed screw and then release the brake lever or brake pedal.
- i. Repeat steps (e) to (h) until all of the air bubbles have disappeared from the brake fluid in the plastic hose.
- j. Tighten the bleed screw to specification.



Bleed screw (front brake caliper)
6 Nm (0.6 m·kg, 4.3 ft·lb)

Bleed screw (rear brake caliper)
6 Nm (0.6 m·kg, 4.3 ft·lb)

- k. Fill the brake fluid reservoir to the proper level with the recommended brake fluid. Refer to “CHECKING THE BRAKE FLUID LEVEL” on page 3-21.

EWA13110

WARNING

After bleeding the hydraulic brake system, check the brake operation.



3. Install:

- Rider seat

Refer to "GENERAL CHASSIS" on page 4-1.

EAS21380

ADJUSTING THE SHIFT PEDAL

NOTE:

The shift pedal position is determined by the installed shift rod length "a".

1. Measure:

- Installed shift rod length "a"
Incorrect → Adjust.

	Installed shift rod length XV19S(C)/ XV19M(C)/ XV19CTS(C)/ XV19CTM(C): 312.0–316.0 mm (12.28–12.44 in) XV19CS(C)/ XV19C(C): 345.0–349.0 mm (13.58–13.74 in)
---	---

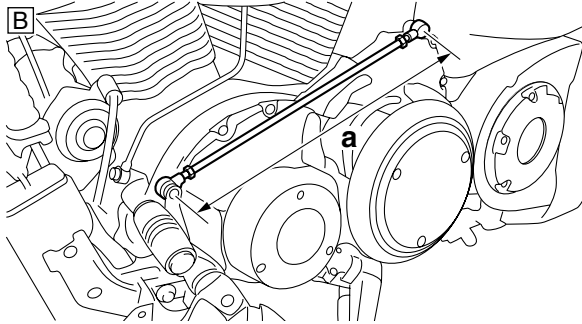
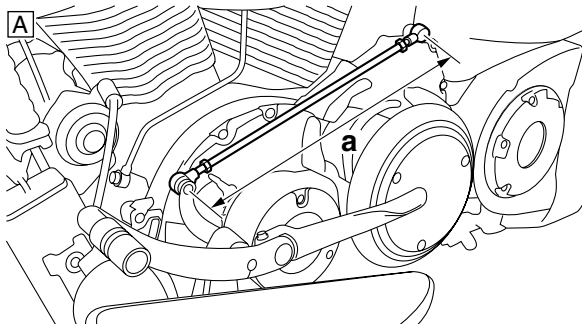

- A. For XV19S(C)/ XV19M(C)/ XV19CTS(C)/ XV19CTM(C)
- B. For XV19CS(C)/ XV19C(C)

2. Adjust:

- Installed shift rod length



a. Loosen both locknuts "1".

- Turn the shift rod "2" in direction "a" or "b" until the specified installed shift rod length is obtained.

Direction "a"

Installed shift rod length increases.

Direction "b"

Installed shift rod length decreases.

NOTE:

- Make sure that the exposed thread length "c" between the locknut and joint on both ends of the shift rod is 10 mm or less (for XV19S(C)/ XV19M(C)/ XV19CTS(C)/ XV19CTM(C)).
- Make sure that the exposed thread length "c" between the locknut and joint on both ends of the shift rod is 7 mm (for XV19CS(C)/ XV19C(C)).

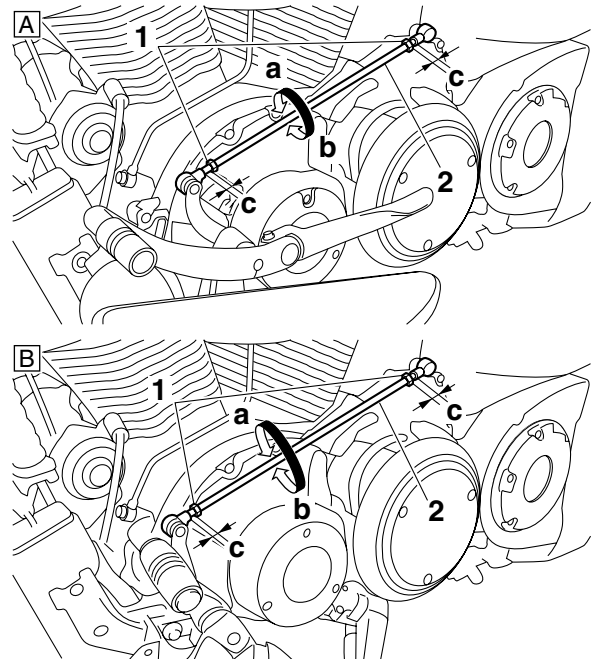

- A. For XV19S(C)/ XV19M(C)/ XV19CTS(C)/ XV19CTM(C)
- B. For XV19CS(C)/ XV19C(C)

c. Tighten both locknuts.

	Locknut (shift rod) 12 Nm (1.2 m·kg, 8.7 ft·lb)
---	---

- Make sure the installed shift rod length is within specification.



EAS21430

ADJUSTING THE DRIVE BELT SLACK

NOTE:

The drive belt slack must be checked at the tightest point on the belt.

ECA14950

CAUTION:

A drive belt that is too tight will overload the engine and other vital parts, and one that is too loose can skip and damage the swing-arm or cause an accident. Therefore, keep the drive belt slack within the specified limits.

NOTE:

Measure the drive belt slack when the engine is cold, and when the drive belt is dry.

1. Stand the vehicle on a level surface.

EWA13120

WARNING

Securely support the vehicle so that there is no danger of it falling over.

NOTE:

Place the vehicle on the sidestand and or on a suitable stand so that the rear wheel is elevated.

2. Check:
 - Drive belt slack "a"

Out of specification → Adjust.

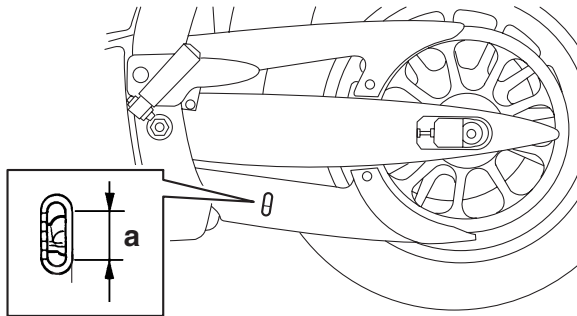

Drive belt slack (on the sidestand)

7.5–13 mm (0.30–0.51 in)

Drive belt slack (on a suitable stand)

14–21 mm (0.55–0.83 in)

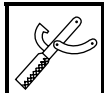

Belt tension gauge

90890-03170

Rear drive belt tension gauge

YM-03170

NOTE:

- The level marks of the level window on the lower drive belt cover are in units of 5 mm (0.20 in). Use them as a standard for measuring the drive belt slack.
- Measure the drive belt slack when the drive belt has been pushed with 4.5 kg (10 lbs) of pressure using a belt tension gauge "1".

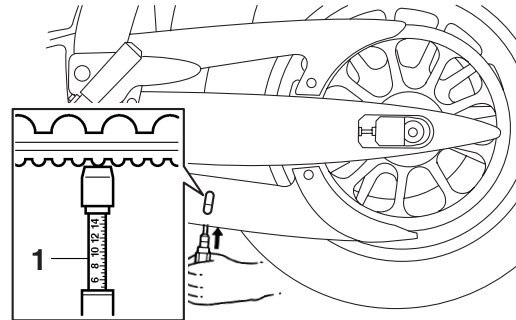

3. Remove:
 - Muffler

Refer to "ENGINE REMOVAL" on page 5-1.

4. Adjust:
 - Drive belt slack

NOTE:

Place the vehicle on a suitable stand so that the rear wheel is elevated.

- a. Loosen the wheel axle nut "1".

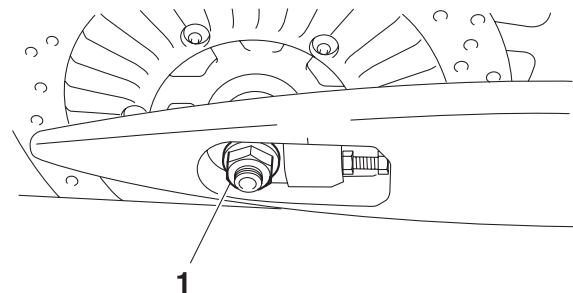

- b. Loosen both locknuts "2".
- c. Turn both adjusting bolts "3" in direction "a" or "b" until the specified drive belt slack is obtained.

Direction "a"
Drive belt is tightened.

Direction "b"
Drive belt is loosened.

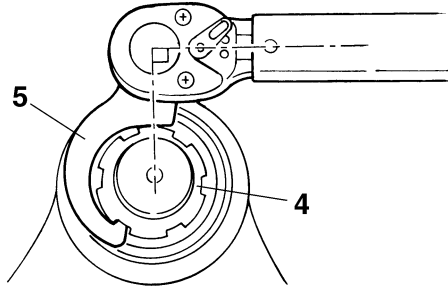

c. Loosen the lower ring nut completely, and then tighten it to specification with a steering nut wrench.

EWA13140

WARNING

Do not overtighten the lower ring nut.



Lower ring nut (final tightening torque)
18 Nm (1.8 m·kg, 13 ft·lb)

d. Check the steering head for looseness or binding by turning the front fork all the way in both directions. If any binding is felt, remove the lower bracket and check the upper and lower bearings.

Refer to "STEERING HEAD" on page 4-77.

e. Install the rubber washer "3".

f. Install the upper ring nut.

g. Finger tighten the upper ring nut "2", then align the slots of both ring nuts. If necessary, hold the lower ring nut and tighten the upper ring nut until their slots are aligned.

h. Install the lock washer "1".

NOTE:

Make sure the lock washer tabs "a" sit correctly in the ring nut slots "b".

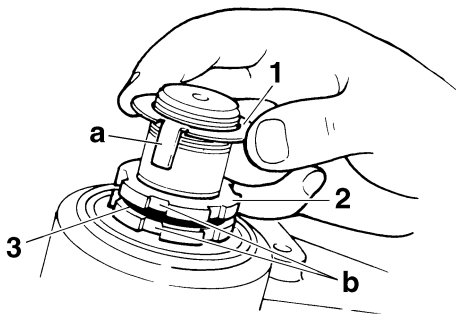

5. Install:

- Upper bracket

Refer to "FRONT FORK" on page 4-66.

EAS21530

CHECKING THE FRONT FORK

1. Stand the vehicle on a level surface.

EWA13120

WARNING

Securely support the vehicle so that there is no danger of it falling over.

2. Check:

- Inner tube
Damage/scratches → Replace.
- Oil seal
Oil leakage → Replace.

3. Hold the vehicle upright and apply the front brake.

4. Check:

- Front fork operation
Push down hard on the handlebar several times and check if the front fork rebounds smoothly.

Rough movement → Repair.

Refer to "FRONT FORK" on page 4-66.

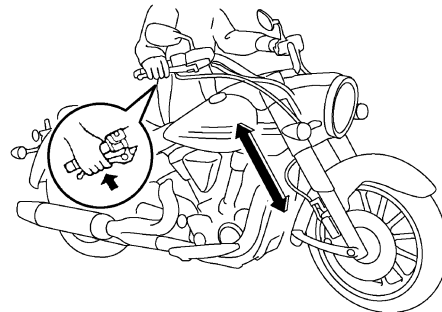

EAS21590

ADJUSTING THE REAR SHOCK ABSORBER ASSEMBLY

EWA13120

WARNING

Securely support the vehicle so that there is no danger of it falling over.

Spring preload

ECA13590

CAUTION:

Never go beyond the maximum or minimum adjustment positions.

1. Adjust:

- Spring preload

NOTE:

Adjust the spring preload with the special wrench "1".



a. Loosen the locknut "2".

b. Turn the adjusting ring “3” in direction “a” or “b”.

Direction “a”
Spring preload is increased (suspension is harder).

Direction “b”
Spring preload is decreased (suspension is softer).



Spring preload adjusting positions

Installed spring length

Minimum

XV19S(C)/ XV19M(C)/
XV19CTS(C)/ XV19CTM(C):
162.0 mm (6.38 in)

XV19CS(C)/ XV19C(C):
163.0 mm (6.42 in)

Standard

XV19S(C)/ XV19M(C):
171.0 mm (6.73 in)

XV19CTS(C)/ XV19CTM(C):
165.0 mm (6.50 in)

XV19CS(C)/ XV19C(C):
172.0 mm (6.77 in)

Maximum

XV19S(C)/ XV19M(C)/
XV19CTS(C)/ XV19CTM(C):
171.0 mm (6.73 in)

XV19CS(C)/ XV19C(C):
172.0 mm (6.77 in)

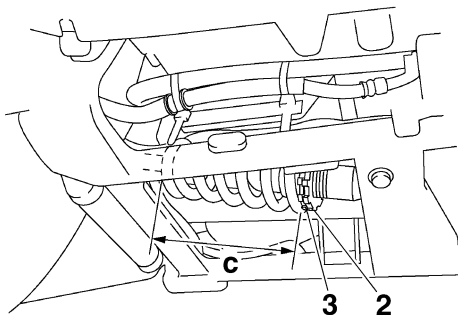
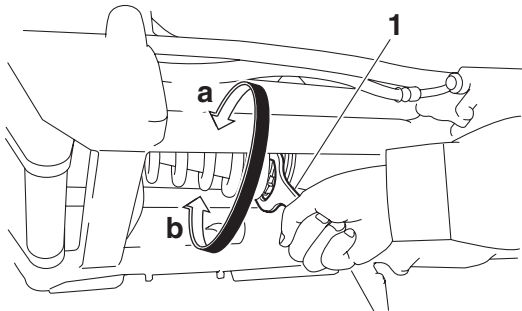

c. Installed spring length

c. Tighten the locknut to specification.

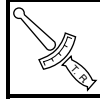

Locknut (rear shock absorber spring preload adjusting nut)
30 Nm (3.0 m·kg, 22 ft·lb)

ECA13600

CAUTION:

Always tighten the locknut against the adjusting nut and torque it to specification.



EAS21650

CHECKING THE TIRES

The following procedure applies to both of the tires.

1. Check:
 - Tire pressure
 - Out of specification → Regulate.

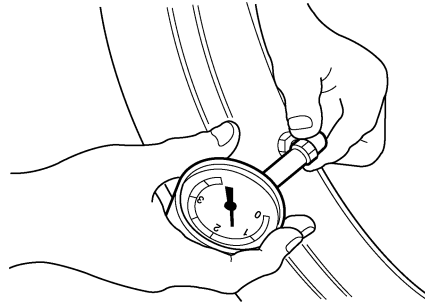

EWA13180

WARNING

- The tire pressure should only be checked and regulated when the tire temperature equals the ambient air temperature.
- The tire pressure and the suspension must be adjusted according to the total weight (including cargo, rider, passenger and accessories) and the anticipated riding speed.
- Operation of an overloaded vehicle could cause tire damage, an accident or an injury. **NEVER OVERLOAD THE VEHICLE.**



Tire air pressure (measured on cold tires)

Loading condition

0–90 kg (0–198 lb)

Front

250 kPa (36 psi) (2.50 kgf/cm²)

Rear

280 kPa (41 psi) (2.80 kgf/cm²)

Loading condition

XV19S(C)/ XV19M(C):

90–210 kg (198–463 lb)

XV19CTS(C)/ XV19CTM(C):

90–186 kg (198–410 lb)

XV19CS(C)/ XV19C(C):

90–204 kg (198–450 lb)

Front

250 kPa (36 psi) (2.50 kgf/cm²)

Rear

280 kPa (41 psi) (2.80 kgf/cm²)

High-speed riding

Front

250 kPa (36 psi) (2.50 kgf/cm²)

Rear

280 kPa (41 psi) (2.80 kgf/cm²)

Maximum load

XV19S(C)/ XV19M(C):

210 kg (463 lb)

XV19CTS(C)/ XV19CTM(C):

186 kg (410 lb)

XV19CS(C)/ XV19C(C):

204 kg (450 lb)

* Total weight of rider, passenger, cargo and accessories

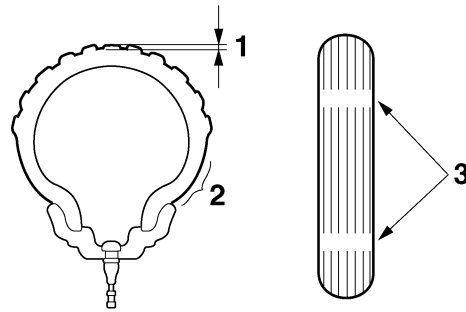

1. Tire tread depth
2. Side wall
3. Wear indicator

EWA14080

WARNING

- Do not use a tubeless tire on a wheel designed only for tube tires to avoid tire failure and personal injury from sudden deflation.
- When using a tube tire, be sure to install the correct tube.
- Always replace a new tube tire and a new tube as a set.
- To avoid pinching the tube, make sure the wheel rim band and tube are centered in the wheel groove.
- Patching a punctured tube is not recommended. If it is absolutely necessary to do so, use great care and replace the tube as soon as possible with a good quality replacement.

EWA13190

WARNING

It is dangerous to ride with a worn-out tire. When the tire tread reaches the wear limit, replace the tire immediately.

2. Check:

- Tire surfaces
Damage/wear → Replace the tire.



Wear limit (front)

1.0 mm (0.04 in)

Wear limit (rear)

1.0 mm (0.04 in)

A

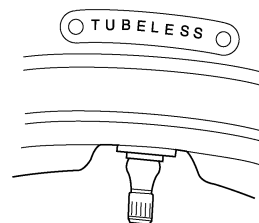

B

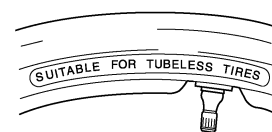

- A. Tire
- B. Wheel

Tube wheel	Tube tire only
Tubeless wheel	Tube or tubeless tire

EWA14090

WARNING

After extensive tests, the tires listed below have been approved by Yamaha Motor Co., Ltd. for this model. The front and rear tires

should always be by the same manufacturer and of the same design. No guarantee concerning handling characteristics can be given if a tire combination other than one approved by Yamaha is used on this vehicle.



Front tire

Size

XV19S(C)/ XV19M(C)/
XV19CTS(C)/ XV19CTM(C):
130/70R18M/C 63H
XV19CS(C)/ XV19C(C):
120/70-21M/C 62H

Manufacturer/model

XV19S(C)/ XV19M(C)/
XV19CTS(C)/ XV19CTM(C):
DUNLOP/D251F

Manufacturer/model

XV19S(C)/ XV19M(C)/
XV19CTS(C)/ XV19CTM(C):
BRIDGESTONE/G851 RADIAL G

Manufacturer/model

XV19CS(C)/ XV19C(C):
METZELER/880 MARATHON



Rear tire

Size

XV19S(C)/ XV19M(C)/
XV19CTS(C)/ XV19CTM(C):
190/60R17M/C 78H
XV19CS(C)/ XV19C(C):
210/40R18M/C 73H

Manufacturer/model

XV19S(C)/ XV19M(C)/
XV19CTS(C)/ XV19CTM(C):
DUNLOP/D251

Manufacturer/model

XV19S(C)/ XV19M(C)/
XV19CTS(C)/ XV19CTM(C):
BRIDGESTONE/G850 RADIAL G

Manufacturer/model

XV19CS(C)/ XV19C(C):
METZELER/880 MARATHON

EWA13210



WARNING

New tires have a relatively low grip on the road surface until they have been slightly worn. Therefore, approximately 100 km should be traveled at normal speed before any high-speed riding is done.

NOTE:

For tires with a direction of rotation mark "1":

- Install the tire with the mark pointing in the direction of wheel rotation.
- Align the mark "2" with the valve installation point.

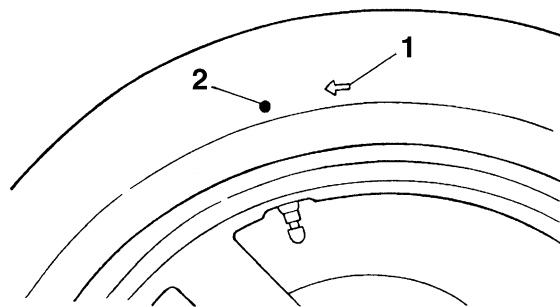

EAS21670

CHECKING THE WHEELS

The following procedure applies to both of the wheels.

1. Check:
 - Wheel
Damage/out-of-round → Replace.

EWA13260



WARNING

Never attempt to make any repairs to the wheel.

NOTE:

After a tire or wheel has been changed or replaced, always balance the wheel.

EAS21690

CHECKING AND LUBRICATING THE CABLES

The following procedure applies to all of the inner and outer cables.

EWA13270



WARNING

Damaged outer cable may cause the cable to corrode and interfere with its movement. Replace damaged outer cable and inner cables as soon as possible.

1. Check:
 - Outer cable
Damage → Replace.
2. Check:
 - Cable operation
Rough movement → Lubricate.



Recommended lubricant
Engine oil or a suitable cable lubricant

NOTE:

Hold the cable end upright and pour a few drops of lubricant into the cable sheath or use a suitable lubricating device.

EAS21700

LUBRICATING THE LEVERS

Lubricate the pivoting point and metal-to-metal moving parts of the levers.



EAS1D77003

LUBRICATING THE PEDALS

Lubricate the pivoting point and metal-to-metal moving parts of the pedal.



EAS21720

LUBRICATING THE SIDESTAND

Lubricate the pivoting point and metal-to-metal moving parts of the sidestand.



EAS21740

LUBRICATING THE REAR SUSPENSION

Lubricate the pivoting point and metal-to-metal moving parts of the rear suspension.

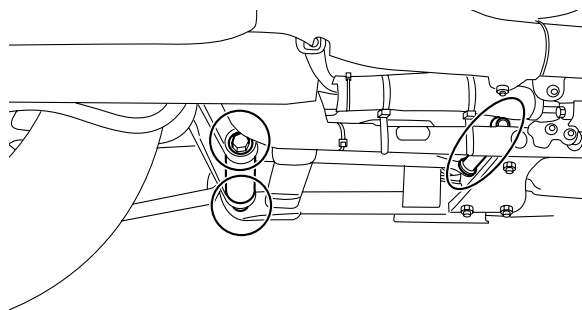

NOTE:

Lubricate the pivoting points and contact surfaces between the connecting rod and frame and between the swingarm and frame.

EAS21750

ELECTRICAL SYSTEM

EAS21760

CHECKING AND CHARGING THE BATTERY

Refer to "ELECTRICAL COMPONENTS" on page 7-67.

EAS21770

CHECKING THE FUSES

Refer to "ELECTRICAL COMPONENTS" on page 7-67.

EAS21790

REPLACING THE HEADLIGHT BULBS (for XV19S(C)/ XV19M(C)/ XV19CTS(C)/ XV19CTM(C))

1. Remove:
 - Windshield (for XV19CTS(C)/ XV19CTM(C))
Refer to "GENERAL CHASSIS" on page 4-1.
2. Remove:
 - Headlight cover "1"

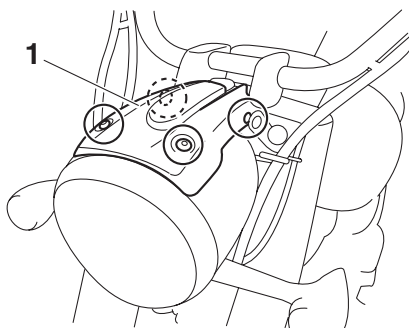

3. Disconnect:
 - Air temperature sensor coupler "1"

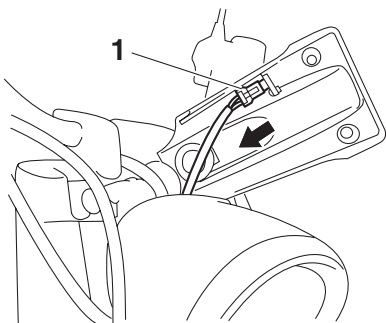

4. Remove:
 - Headlight lens unit "1"

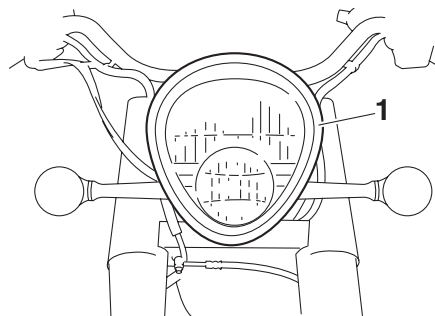

5. Replace:
 - Low beam headlight bulb



- a. Disconnect:
 - Headlight coupler "1"
- b. Remove:
 - Headlight bulb "2"

EWA13320



Since the headlight bulb gets extremely hot, keep flammable products and your hands away from the bulb until it has cooled down.

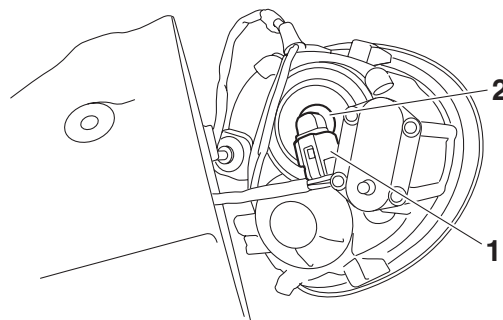

- c. Install:
 - Headlight bulb **New**
Secure the new headlight bulb with the headlight bulb holder.

ECA13690



Avoid touching the glass part of the headlight bulb to keep it free from oil, otherwise the transparency of the glass, the life of the bulb and the luminous flux will be adversely affected. If the headlight bulb gets soiled, thoroughly clean it with a cloth moistened with alcohol or lacquer thinner.

- d. Connect:
 - Headlight coupler



6. Replace:
 - High beam headlight bulb



- a. Remove:

- Headlight bulb cover “1”

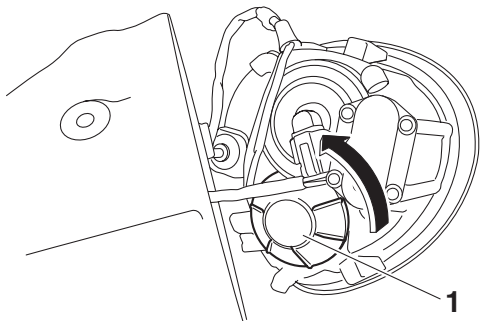

- Disconnect:
 - Headlight coupler “1”
- Detach:
 - Headlight bulb holder “2”

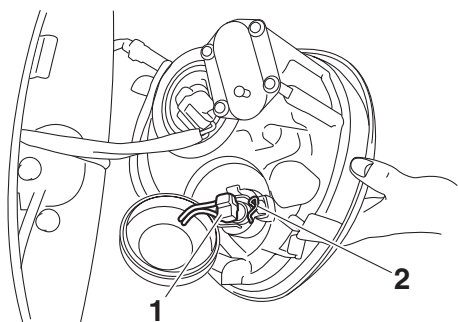

- Remove:
 - Headlight bulb

EWA13320

WARNING

Since the headlight bulb gets extremely hot, keep flammable products and your hands away from the bulb until it has cooled down.

- Install:

- Headlight bulb **New**
Secure the new headlight bulb with the headlight bulb holder.

ECA13690

CAUTION:

Avoid touching the glass part of the headlight bulb to keep it free from oil, otherwise the transparency of the glass, the life of the bulb and the luminous flux will be adversely affected. If the headlight bulb gets soiled, thoroughly clean it with a cloth moistened with alcohol or lacquer thinner.

- Attach:
 - Headlight bulb holder
- Connect:
 - Headlight coupler
- Install:
 - Headlight bulb cover

- Install:
 - Headlight lens unit
- Connect:
 - Air temperature sensor coupler
- Install:
 - Headlight cover



Headlight cover bolt
7 Nm (0.7 m·kg, 5.1 ft·lb)

- Install:
 - Windshield (for XV19CTS(C)/ XV19CTM(C))
Refer to “GENERAL CHASSIS” on page 4-1.

EAS1D77005

REPLACING THE HEADLIGHT BULB (for XV19CS(C)/ XV19C(C))

- Remove:
 - Headlight lens unit “1”

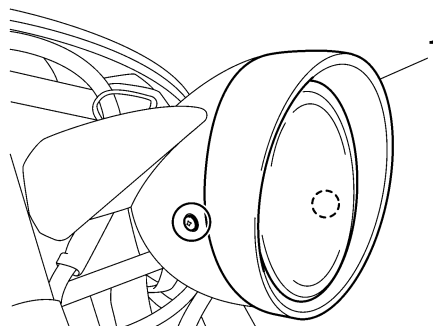

- Disconnect:
 - Headlight coupler “1”
- Remove:
 - Headlight bulb cover “2”

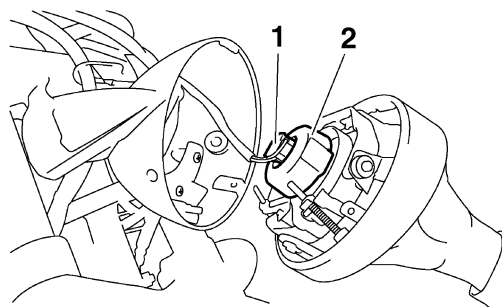

- Detach:
 - Headlight bulb holder “1”
- Remove:
 - Headlight bulb “2”

EWA13320

WARNING

Since the headlight bulb gets extremely hot, keep flammable products and your hands away from the bulb until it has cooled down.



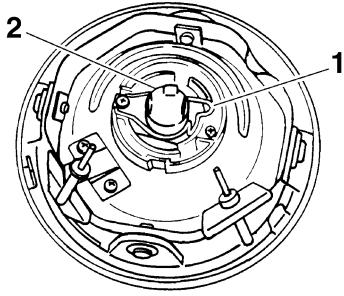

6. Install:

- Headlight bulb **New**
Secure the new headlight bulb with the headlight bulb holder.

ECA13690

CAUTION:

Avoid touching the glass part of the headlight bulb to keep it free from oil, otherwise the transparency of the glass, the life of the bulb and the luminous flux will be adversely affected. If the headlight bulb gets soiled, thoroughly clean it with a cloth moistened with alcohol or lacquer thinner.

7. Attach:

- Headlight bulb holder

8. Install:

- Headlight bulb cover

9. Connect:

- Headlight coupler

10. Install:

- Headlight lens unit

EAS21810

ADJUSTING THE HEADLIGHT BEAMS

1. Adjust:

- Headlight beam (vertically)

a. Turn the adjusting bolt "1" in direction "a" or "b".

Direction "a"
Headlight beam is raised.
Direction "b"
Headlight beam is lowered.

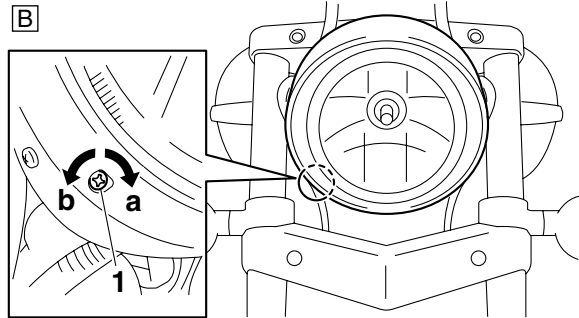
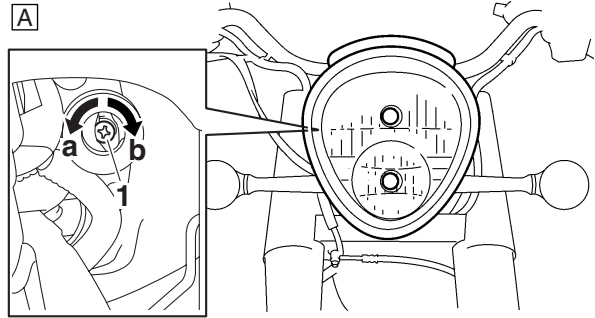

- A. For XV19S(C)/ XV19M(C)/ XV19CTS(C)/ XV19CTM(C)
- B. For XV19CS(C)/ XV19C(C)



2. Adjust:

- Headlight beam (horizontally)



a. Turn the adjusting bolt "1" in direction "a" or "b".

Direction "a"
Headlight beam moves to the right.
Direction "b"
Headlight beam moves to the left.

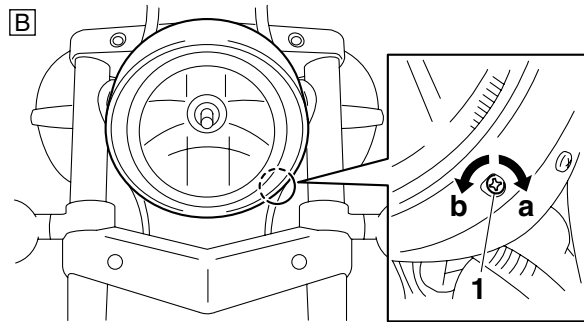
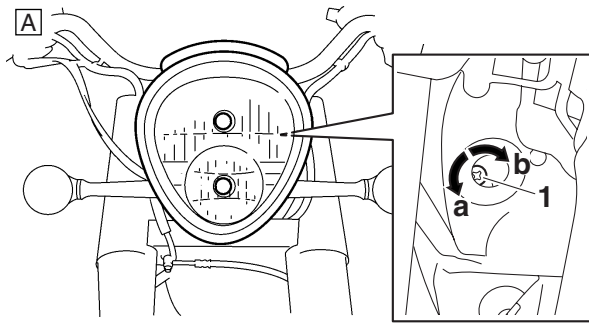

- A. For XV19S(C)/ XV19M(C)/ XV19CTS(C)/ XV19CTM(C)
- B. For XV19CS(C)/ XV19C(C)



CHASSIS

GENERAL CHASSIS	4-1
REMOVING THE WINDSHIELD	4-2
ASSEMBLING THE WINDSHIELD	4-2
INSTALLING THE WINDSHIELD.....	4-2
REMOVING THE BACKREST	4-5
ASSEMBLING THE BACKREST.....	4-5
INSTALLING THE BACKREST	4-5
CHECKING THE SIDEBAG BRACKET SPRING NUTS.....	4-8
FRONT WHEEL	4-18
REMOVING THE FRONT WHEEL.....	4-22
DISASSEMBLING THE FRONT WHEEL.....	4-22
CHECKING THE FRONT WHEEL	4-22
ASSEMBLING THE FRONT WHEEL.....	4-23
ADJUSTING THE FRONT WHEEL STATIC BALANCE	4-23
INSTALLING THE FRONT WHEEL (FRONT BRAKE DISCS)	4-24
REAR WHEEL	4-27
REMOVING THE REAR WHEEL (DISC)	4-32
DISASSEMBLING THE REAR WHEEL	4-32
CHECKING THE REAR WHEEL.....	4-32
CHECKING THE REAR BRAKE CALIPER BRACKET	4-32
CHECKING THE REAR WHEEL DRIVE HUB	4-33
CHECKING AND REPLACING THE REAR WHEEL PULLEY	4-33
ASSEMBLING THE REAR WHEEL	4-33
ADJUSTING THE REAR WHEEL STATIC BALANCE.....	4-33
INSTALLING THE REAR WHEEL (DISC).....	4-33
FRONT BRAKE	4-35
INTRODUCTION	4-40
CHECKING THE FRONT BRAKE DISCS.....	4-40
REPLACING THE FRONT BRAKE PADS	4-41
REMOVING THE FRONT BRAKE CALIPERS	4-42
DISASSEMBLING THE FRONT BRAKE CALIPERS.....	4-42
CHECKING THE FRONT BRAKE CALIPERS	4-43
ASSEMBLING THE FRONT BRAKE CALIPERS.....	4-43
INSTALLING THE FRONT BRAKE CALIPERS	4-43
REMOVING THE FRONT BRAKE MASTER CYLINDER	4-44
CHECKING THE FRONT BRAKE MASTER CYLINDER.....	4-45
ASSEMBLING THE FRONT BRAKE MASTER CYLINDER	4-45
INSTALLING THE FRONT BRAKE MASTER CYLINDER.....	4-45

REAR BRAKE	4-47
INTRODUCTION	4-53
CHECKING THE REAR BRAKE DISC	4-53
REPLACING THE REAR BRAKE PADS	4-53
REMOVING THE REAR BRAKE CALIPER	4-54
DISASSEMBLING THE REAR BRAKE CALIPER	4-54
CHECKING THE REAR BRAKE CALIPER	4-55
ASSEMBLING THE REAR BRAKE CALIPER	4-55
INSTALLING THE REAR BRAKE CALIPER	4-55
REMOVING THE REAR BRAKE MASTER CYLINDER	4-56
CHECKING THE REAR BRAKE MASTER CYLINDER	4-57
ASSEMBLING THE REAR BRAKE MASTER CYLINDER	4-57
INSTALLING THE REAR BRAKE MASTER CYLINDER	4-57
HANDLEBAR	4-59
REMOVING THE HANDLEBAR	4-63
CHECKING THE HANDLEBAR	4-63
INSTALLING THE HANDLEBAR	4-63
FRONT FORK	4-66
REMOVING THE FRONT FORK LEGS	4-71
DISASSEMBLING THE FRONT FORK LEGS	4-71
CHECKING THE FRONT FORK LEGS	4-72
ASSEMBLING THE FRONT FORK LEGS	4-72
INSTALLING THE FRONT FORK LEGS (for XV19S(C)/ XV19M(C)/ XV19CTS(C)/ XV19CTM(C))	4-75
INSTALLING THE FRONT FORK LEGS (for XV19CS(C)/ XV19C(C)) ...	4-76
STEERING HEAD	4-77
REMOVING THE LOWER BRACKET	4-81
CHECKING THE STEERING HEAD	4-81
INSTALLING THE STEERING HEAD (for XV19S(C)/ XV19M(C)/ XV19CTS(C)/ XV19TMX(C))	4-81
INSTALLING THE STEERING HEAD (for XV19CS(C)/ XV19C(C))	4-82
REAR SHOCK ABSORBER ASSEMBLY AND SWINGARM	4-83
HANDLING THE REAR SHOCK ABSORBER	4-86
DISPOSING OF A REAR SHOCK ABSORBER	4-86
REMOVING THE REAR SHOCK ABSORBER ASSEMBLY AND SWINGARM	4-86
CHECKING THE REAR SHOCK ABSORBER ASSEMBLY	4-87
CHECKING THE CONNECTING ARM AND RELAY ARM	4-87
CHECKING THE SWINGARM	4-87
INSTALLING THE RELAY ARM, REAR SHOCK ABSORBER ASSEMBLY AND CONNECTING ARMS	4-87
INSTALLING THE SWINGARM	4-89

BELT DRIVE	4-90
REMOVING THE DRIVE BELT AND DRIVE PULLEY	4-92
CHECKING THE DRIVE BELT	4-92
INSTALLING THE DRIVE BELT AND DRIVE PULLEY	4-92

EAS21830

GENERAL CHASSIS

Removing the windshield (for XV19CTS(C)/ XV19CTM(C))

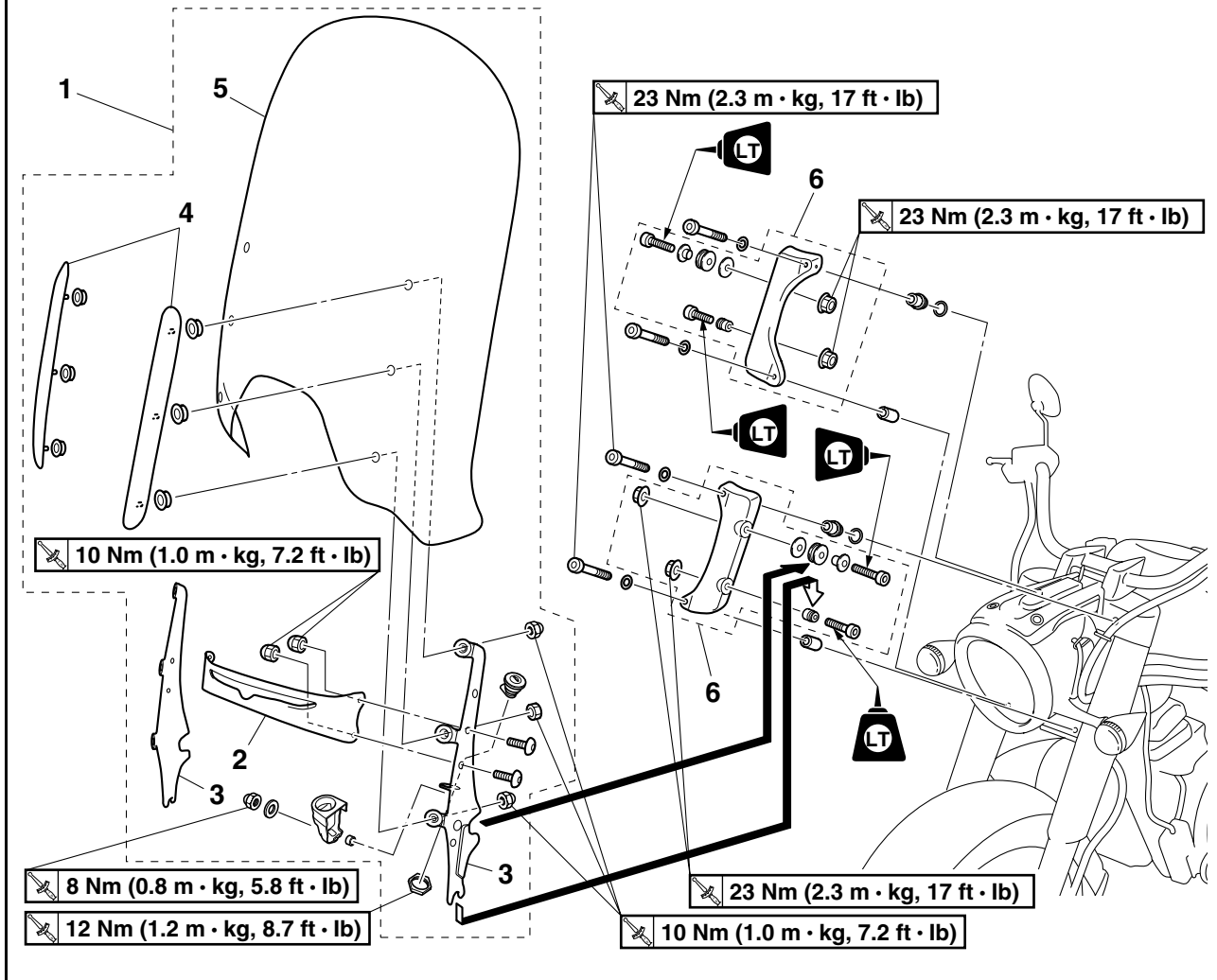

Order	Job/Parts to remove	Q'ty	Remarks
1	Windshield	1	
2	Windshield bracket brace	1	
3	Windshield bracket (left and right)	2	
4	Windshield brace (left and right)	2	
5	Windshield screen	1	
6	Windshield holder bracket assembly (left and right)	2	
			For installation, reverse the removal procedure.

ET1D71039

REMOVING THE WINDSHIELD

1. Remove:
 - Windshield

- a. Insert the key "1" into the windshield lock, turn it clockwise and then remove the key.

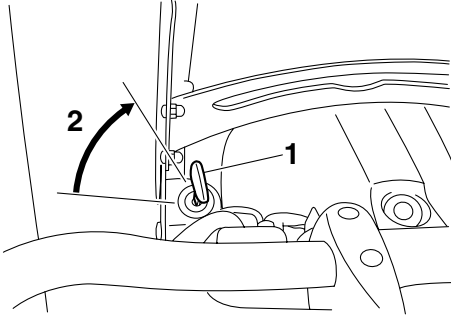

2. Unlock.

- b. Remove the windshield by pushing it forward, and then pulling it upward as shown.

EW1D71016

WARNING

Be careful not to push the vehicle forward when removing the windshield. The vehicle could fall off the sidestand.

EC1D71025

CAUTION:

Securely hold the windshield to prevent it from falling when removing.

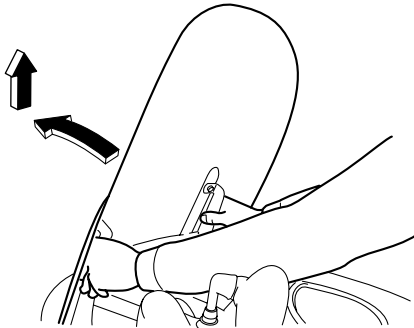

ET1D71045

ASSEMBLING THE WINDSHIELD

1. Install:
 - Windshield lock "1"

NOTE:

Align the projection "a" on the lock "1" with the slot "b" in the windshield bracket "2".

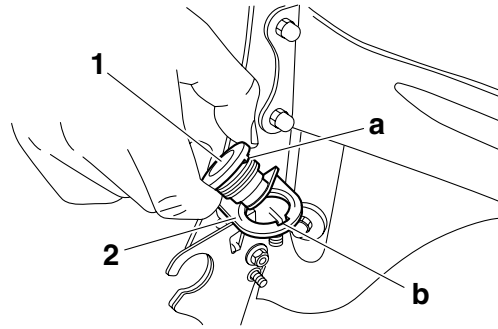

ET1D71040

INSTALLING THE WINDSHIELD

1. Install:
 - Right windshield holder bracket assembly "1"

NOTE:

Pass the throttle cables "2" between the front fork and the right windshield holder bracket assembly.

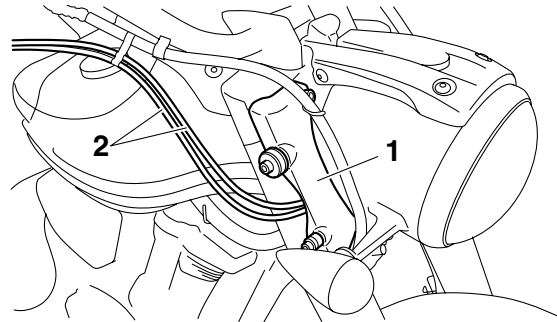

2. Install:
 - Windshield

- a. Fit the slot "a" in each windshield bracket (left and right side) into its holder "b".

NOTE:

Make sure that the throttle cables "1" are not pinched.

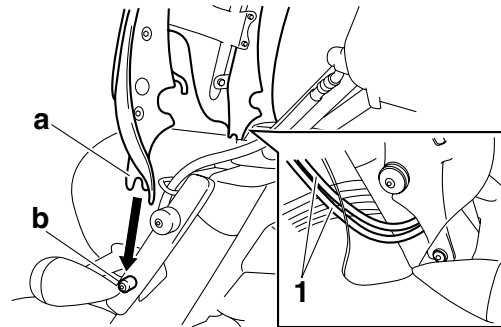

- b. Push the windshield backward until it snaps into place.

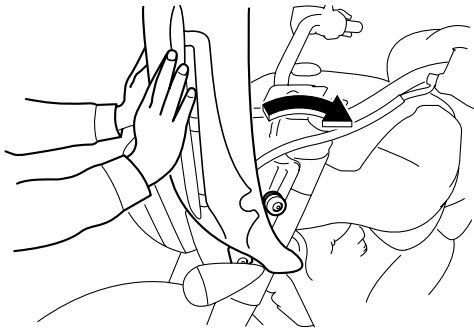

c. Insert the key into the windshield lock, turn it counterclockwise until it stops to lock the fastener, and then remove the key.

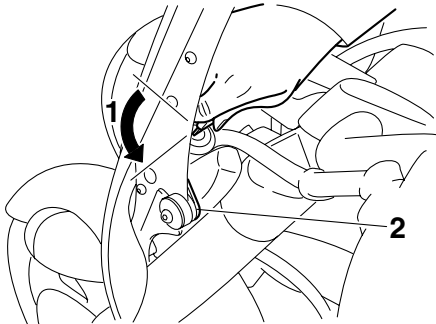

- 1. Lock
- 2. Fastener



Removing the sidebags and backrest (for XV19CTS(C)/ XV19CTM(C))

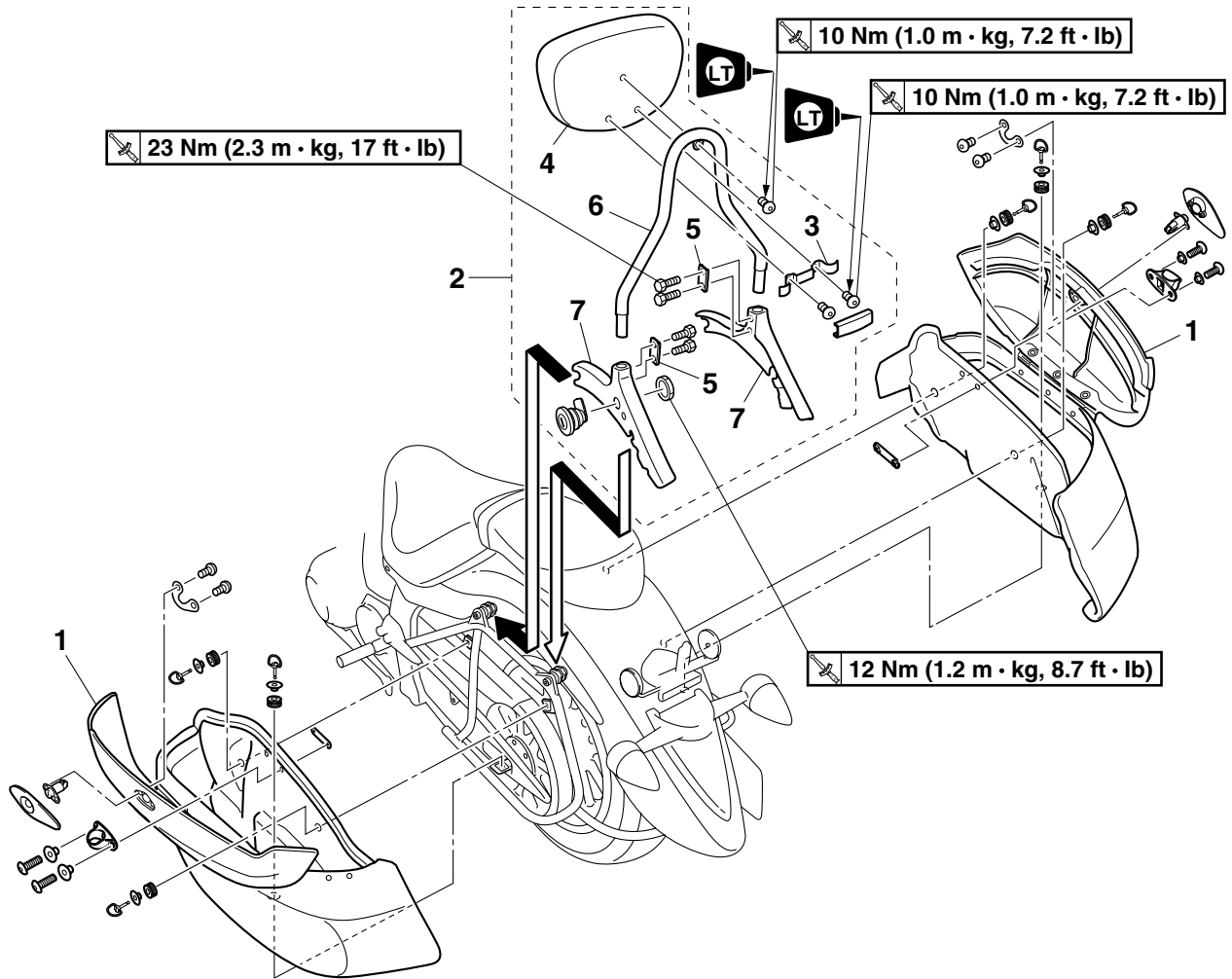

Order	Job/Parts to remove	Q'ty	Remarks
1	Sidebag (left and right)	2	NOTE: _____ Water can be harmful to untreated leather. Use Yamaha Saddle Soap or another quality brand according to the manufacturer's directions to clean the leather on the sidebags. Polish the dry leather with a soft cloth, and then treat with Yamaha Mink Oil or another high-quality leather protectant for increased water resistance.
2	Backrest assembly	1	
3	Backrest upper bracket stay	1	
4	Backrest pad	1	
5	Backrest plate	2	
6	Backrest upper bracket	1	
7	Backrest lower bracket (left and right)	2	
			For installation, reverse the removal procedure.

ET1D71041

REMOVING THE BACKREST

1. Remove:
 - Backrest



- a. Open the sidebag lids.
- b. Insert the key "1" into the backrest lock, turn it counterclockwise, and then remove the key.

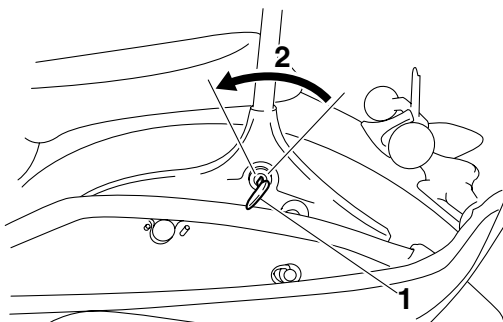

2. Unlock.

- c. Pull the lever "1" on each side of the backrest upward.

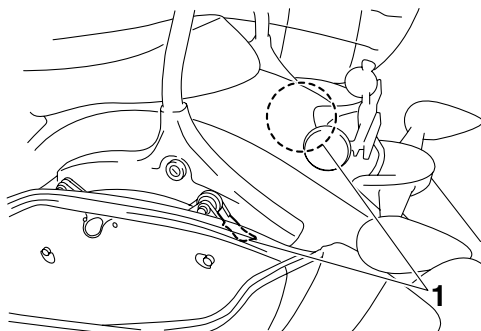

- d. While holding the levers in the upward position, lift the backrest upward and remove it by pulling it to the rear.

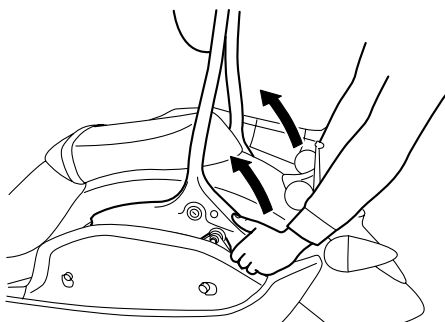

ET1D71046

ASSEMBLING THE BACKREST

1. Install:
 - Backrest lock "1"

NOTE:

Align the projection "a" on the lock "1" with the slot "b" in the left backrest lower bracket "2".

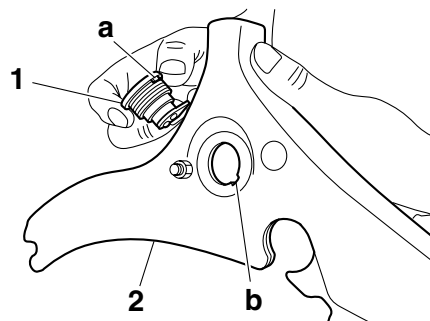

2. Install:
 - Backrest lower brackets "1"
 - Backrest upper bracket "2"
 - Backrest plate

NOTE:

Before tightening the bolts "3" to specification, temporarily install the backrest lower brackets on the backrest holders, making sure not to push down on the rear of the brackets. The lower bolts cannot be tightened when the backrest lower brackets are installed completely.

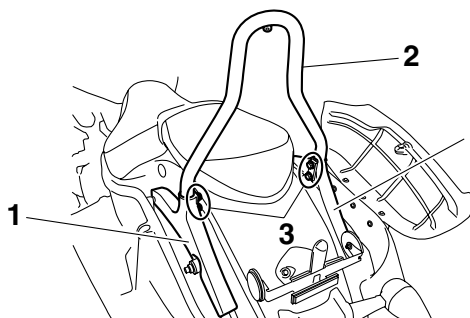

ET1D71042

INSTALLING THE BACKREST

1. Install:
 - Backrest



- a. Fit the slot "a" on each backrest bracket (left and right side) into the groove of its holder "b".

EC1D71026

CAUTION:

Be careful not to scratch the rear fender when fitting the slot into the groove.

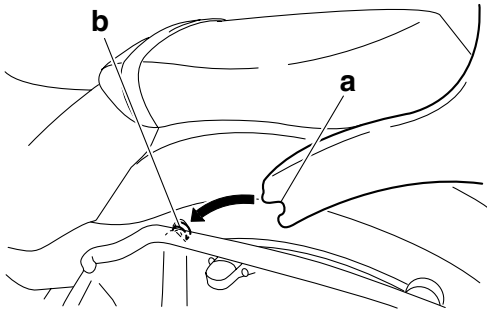

- b. Push the rear of the backrest down smoothly but forcefully to lock it in place and make sure that the lever hook “1” on each side is securely fit over its holder “2”.

EW1D71017

WARNING

Both lever hooks must be securely fitted over their holder. If the backrest is loose, a passenger might lose balance and fall.

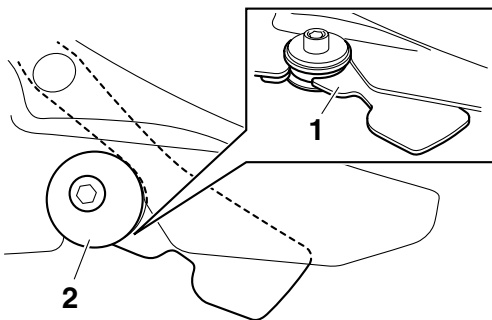
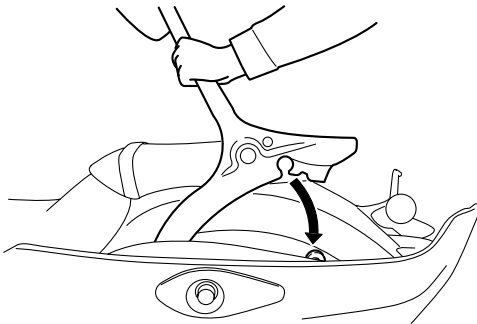

- c. Insert the key into the backrest lock, turn it clockwise, and then remove the key.



Removing the sidebag brackets (for XV19CTS(C)/ XV19CTM(C))

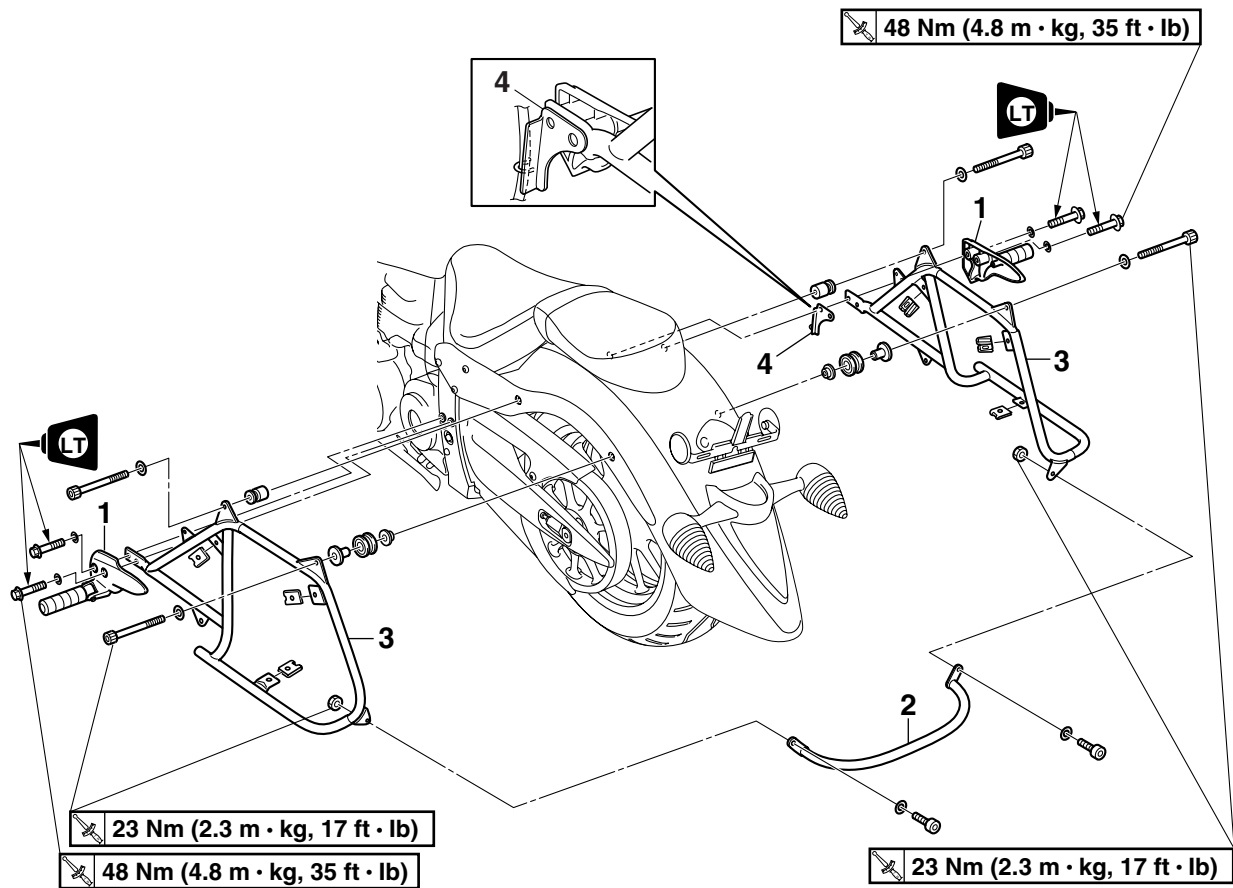

Order	Job/Parts to remove	Q'ty	Remarks
	Sidebag/Backrest		Refer to "GENERAL CHASSIS" on page 4-1.
1	Passenger footrest (left and right)	2	
2	Sidebag bracket brace	1	
3	Sidebag bracket (left and right)	2	NOTE: _____ Remove only one sidebag bracket at a time. If both brackets are removed at the same time, the rear fender will fall.
4	O ₂ sensor lead guide	1	NOTE: _____ Pass the O ₂ sensor lead through the guide.
			For installation, reverse the removal procedure.

ET1D71047

CHECKING THE SIDEBAG BRACKET SPRING NUTS

1. Check:

- Sidebag bracket spring nut height "a"
Out of specification → Adjust.

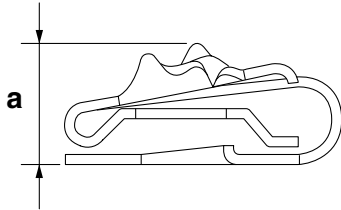
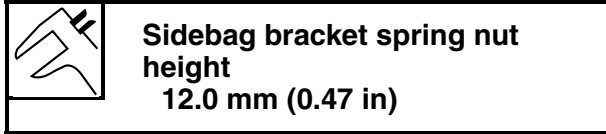

2. Check:

- Sidebag bracket spring nuts
Damage → Replace.

Removing the seats and side covers

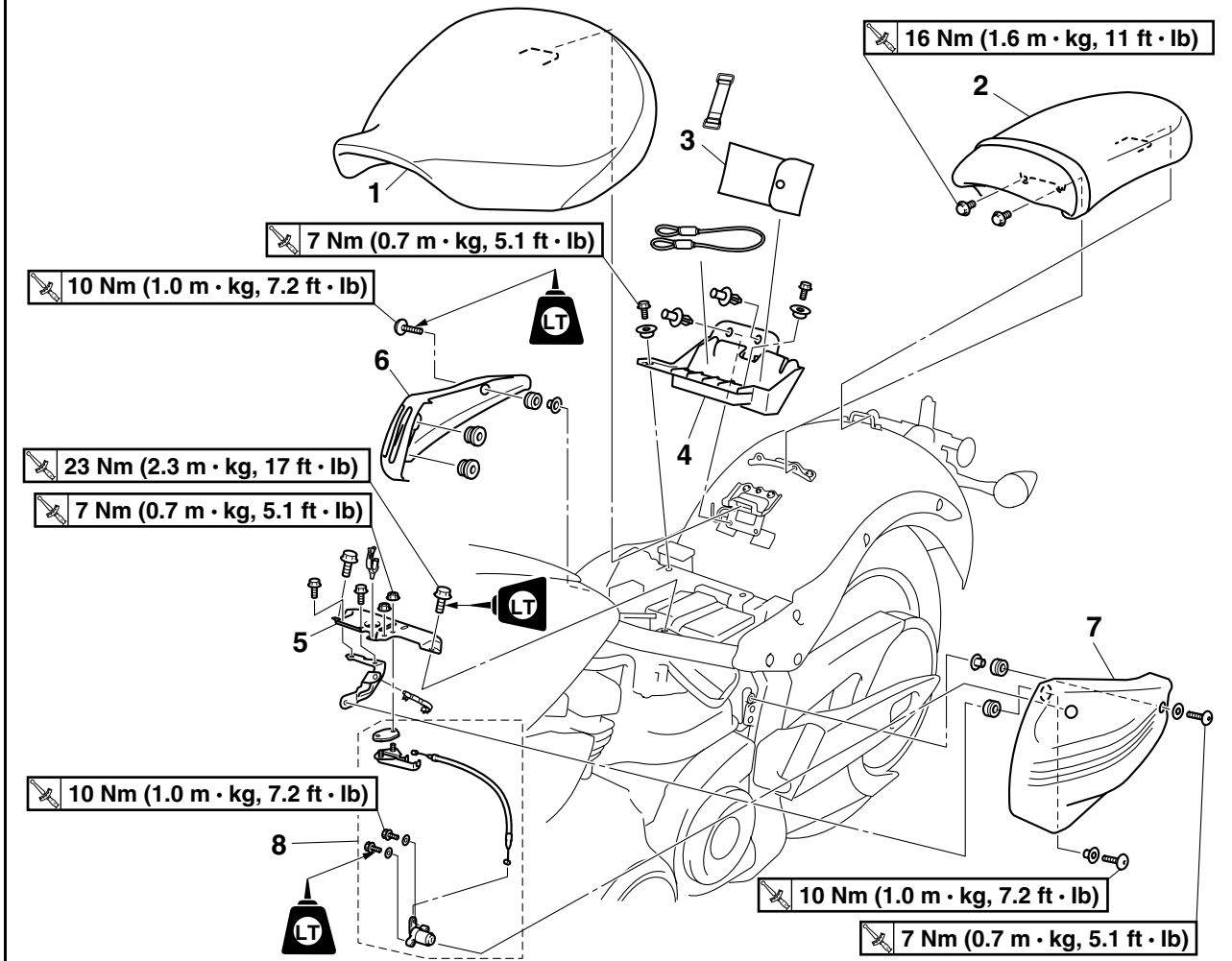

Order	Job/Parts to remove	Q'ty	Remarks
1	Rider seat	1	
2	Passenger seat	1	
3	Tool kit	1	
4	Tool kit tray	1	
5	Rider seat bracket assembly	1	
6	Right side cover	1	
7	Left side cover	1	
8	Seat lock cable assembly	1	
			For installation, reverse the removal procedure.

Removing the headlight (for XV19S(C)/ XV19M(C)/ XV19CTS(C)/ XV19CTM(C))

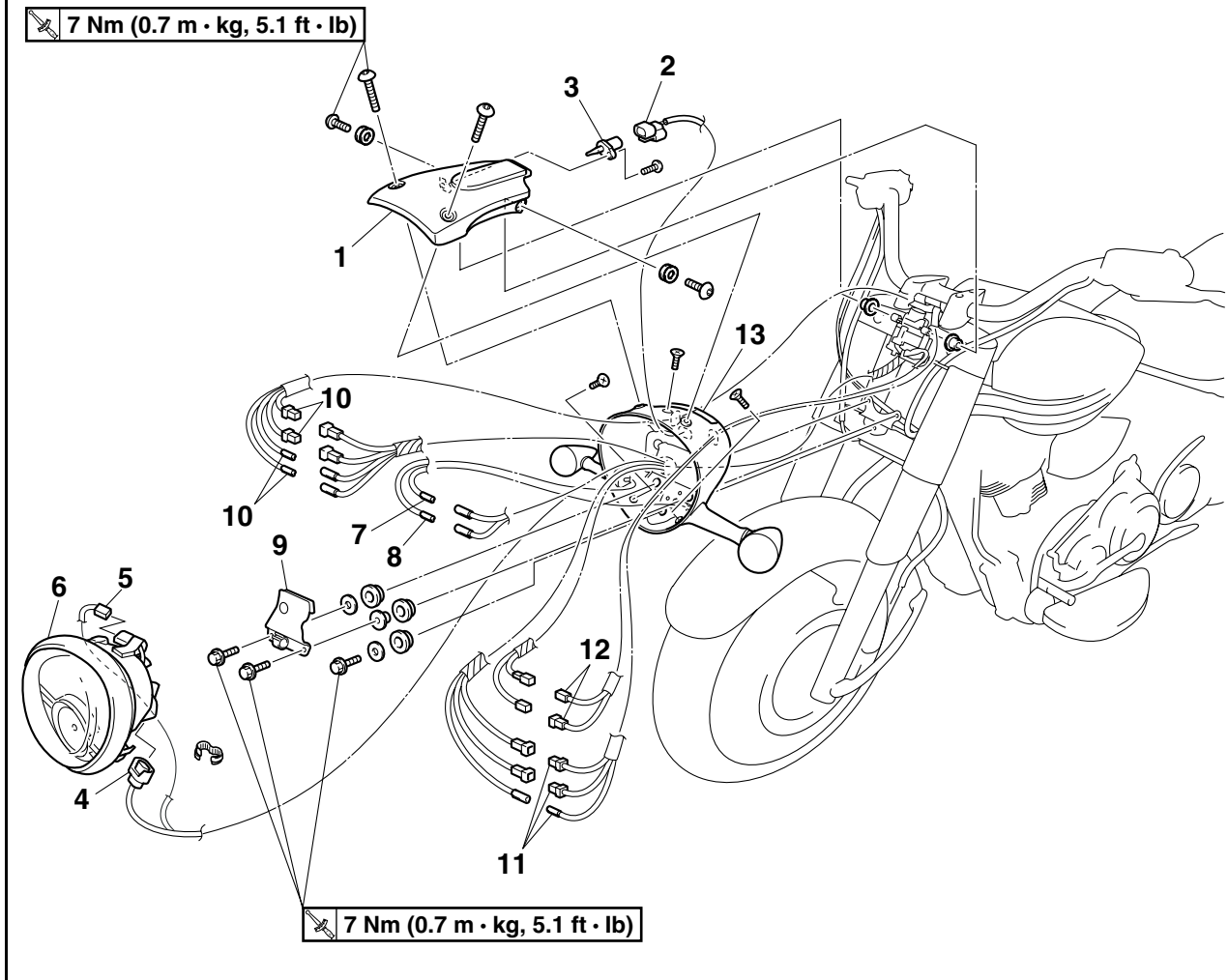

Order	Job/Parts to remove	Q'ty	Remarks
1	Headlight cover	1	
2	Air temperature sensor coupler	1	Disconnect.
3	Air temperature sensor	1	
4	Headlight (low beam) coupler	1	Disconnect.
5	Headlight (high beam) coupler	1	Disconnect.
6	Headlight lens unit	1	
7	Front left turn signal/position light coupler	1	Disconnect.
8	Front right turn signal/position light coupler	1	Disconnect.
9	Wire harness stopper bracket	1	
10	Left handlebar switch coupler	4	Disconnect.
11	Right handlebar switch coupler	3	Disconnect.
12	Main switch coupler	2	Disconnect.
13	Headlight body	1	
			For installation, reverse the removal procedure.

Removing the headlight (for XV19CS(C)/ XV19C(C))

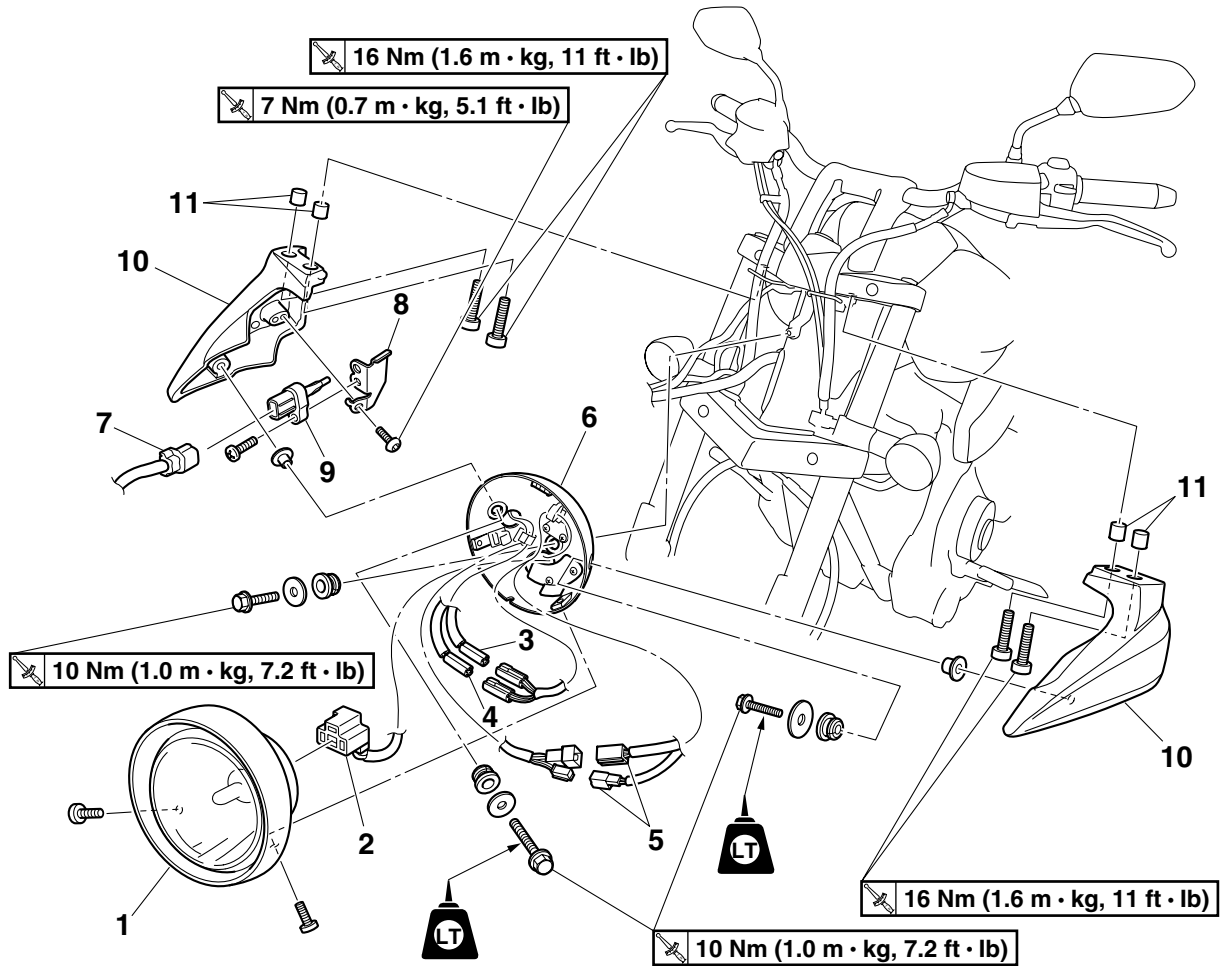

Order	Job/Parts to remove	Q'ty	Remarks
1	Headlight lens unit	1	
2	Headlight coupler	1	Disconnect.
3	Front left turn signal/position light coupler	1	Disconnect.
4	Front right turn signal/position light coupler	1	Disconnect.
5	Main switch coupler	2	Disconnect.
6	Headlight body	1	
7	Air temperature sensor coupler	1	Disconnect.
8	Air temperature sensor bracket	1	
9	Air temperature sensor	1	
10	Headlight bracket	2	
11	Spacer	4	
			For installation, reverse the removal procedure.

Removing the air filter case (for XV19S(C)/ XV19M(C)/ XV19CTS(C)/ XV19CTM(C))

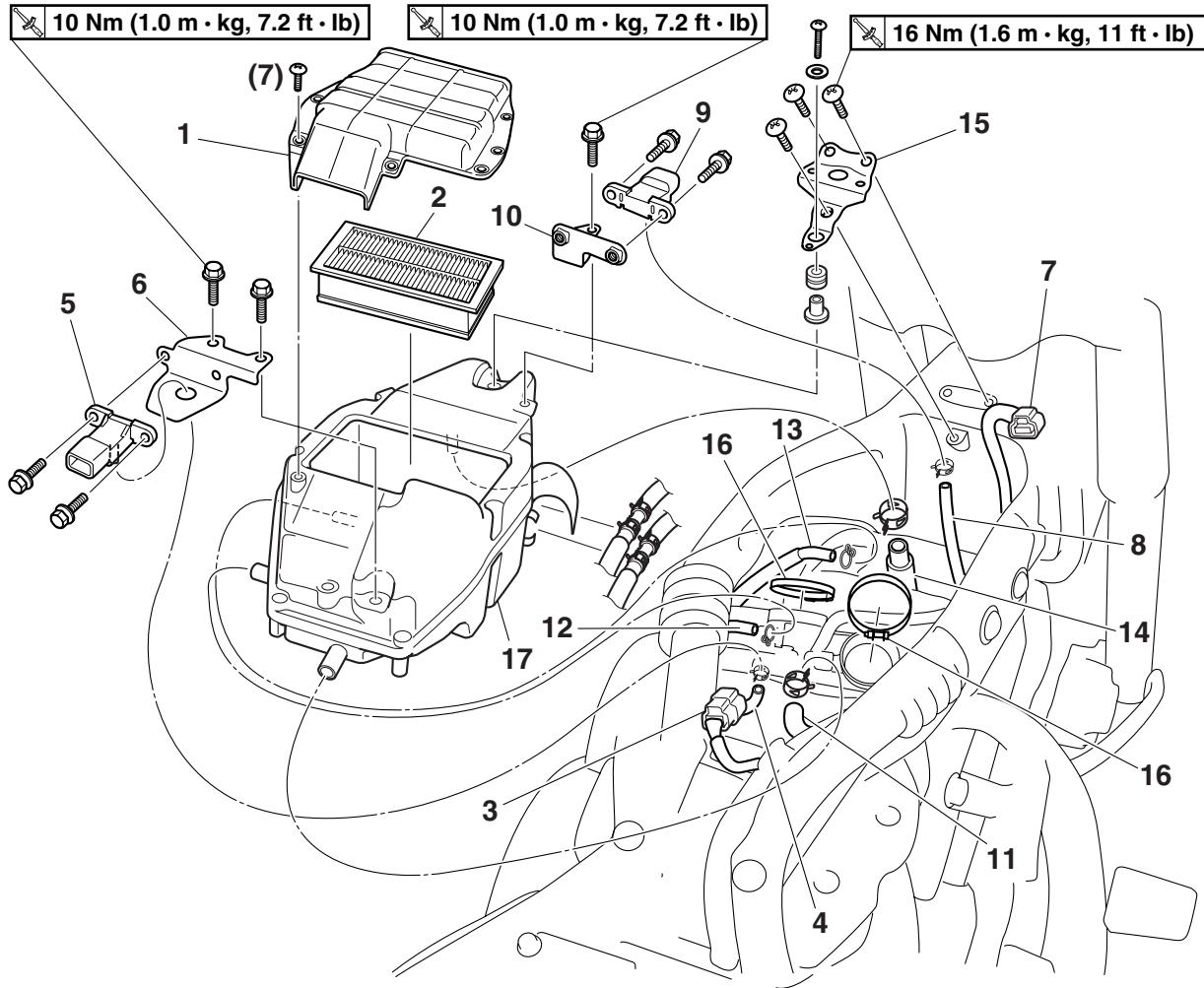

Order	Job/Parts to remove	Q'ty	Remarks
	Rider seat		Refer to "GENERAL CHASSIS" on page 4-1.
	Fuel tank		Refer to "FUEL TANK" on page 6-1.
	Pressure regulator cover		Refer to "THROTTLE BODIES" on page 6-7.
1	Air filter case cover	1	
2	Air filter element	1	
3	Cylinder-#1 intake air pressure sensor coupler	1	Disconnect.
4	Cylinder-#1 intake air pressure sensor hose	1	Disconnect.
5	Cylinder-#1 intake air pressure sensor	1	
6	Cylinder-#1 intake air pressure sensor bracket	1	
7	Cylinder-#2 intake air pressure sensor coupler	1	Disconnect.
8	Cylinder-#2 intake air pressure sensor hose	1	Disconnect.
9	Cylinder-#2 intake air pressure sensor	1	
10	Cylinder-#2 intake air pressure sensor bracket	1	
11	Cylinder head breather hose	1	Disconnect.
12	Air filter case breather hose 1	1	Disconnect.
13	Air filter case breather hose 2	1	Disconnect.
14	ISC (idle speed control) unit inlet hose	1	Disconnect.

Removing the air filter case (for XV19S(C)/ XV19M(C)/ XV19CTS(C)/ XV19CTM(C))

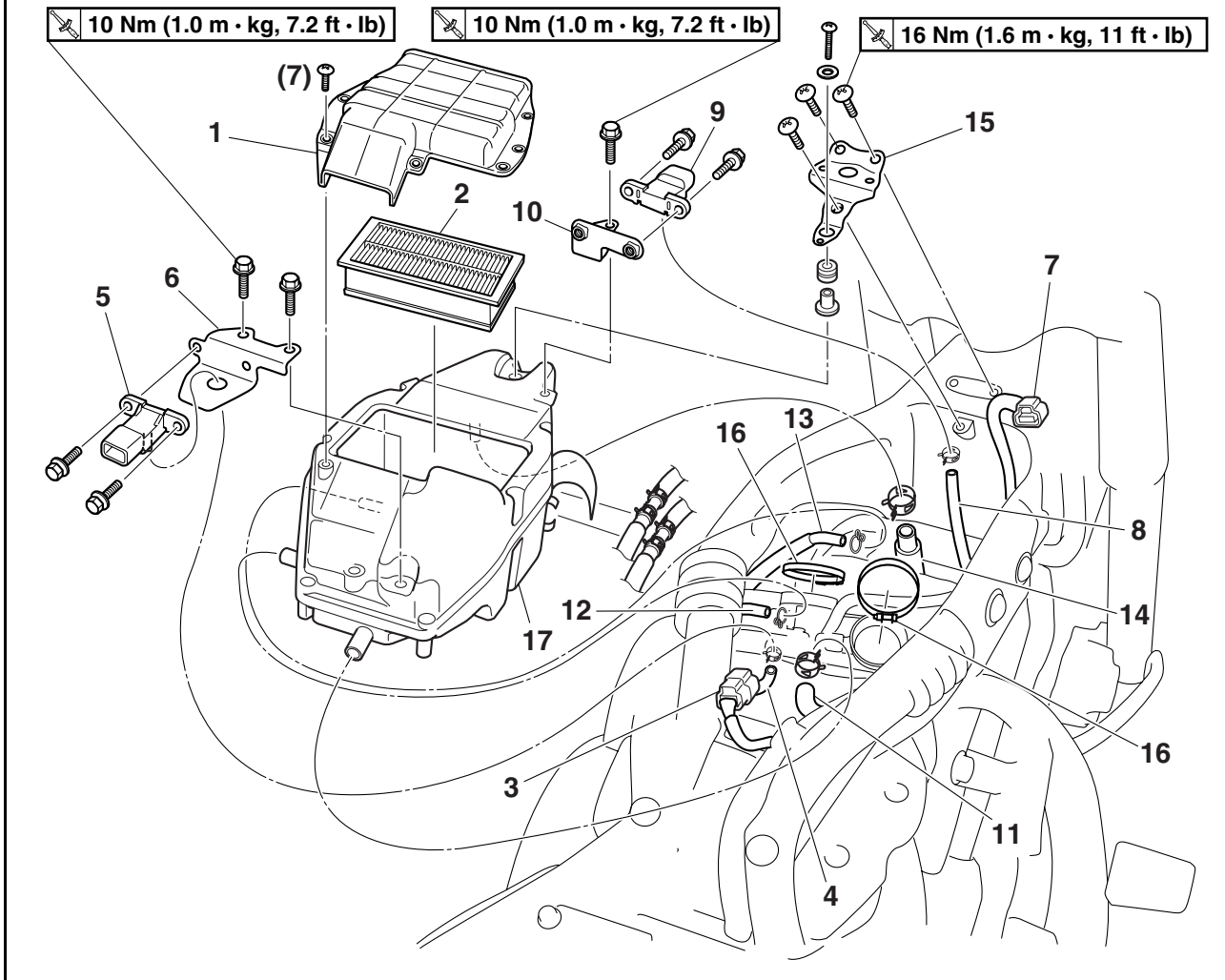

Order	Job/Parts to remove	Q'ty	Remarks
15	Air filter case bracket	1	
16	Air filter case joint clamp screw	2	Loosen.
17	Air filter case	1	
			For installation, reverse the removal procedure.

Removing the air filter case (for XV19CS(C)/ XV19C(C))

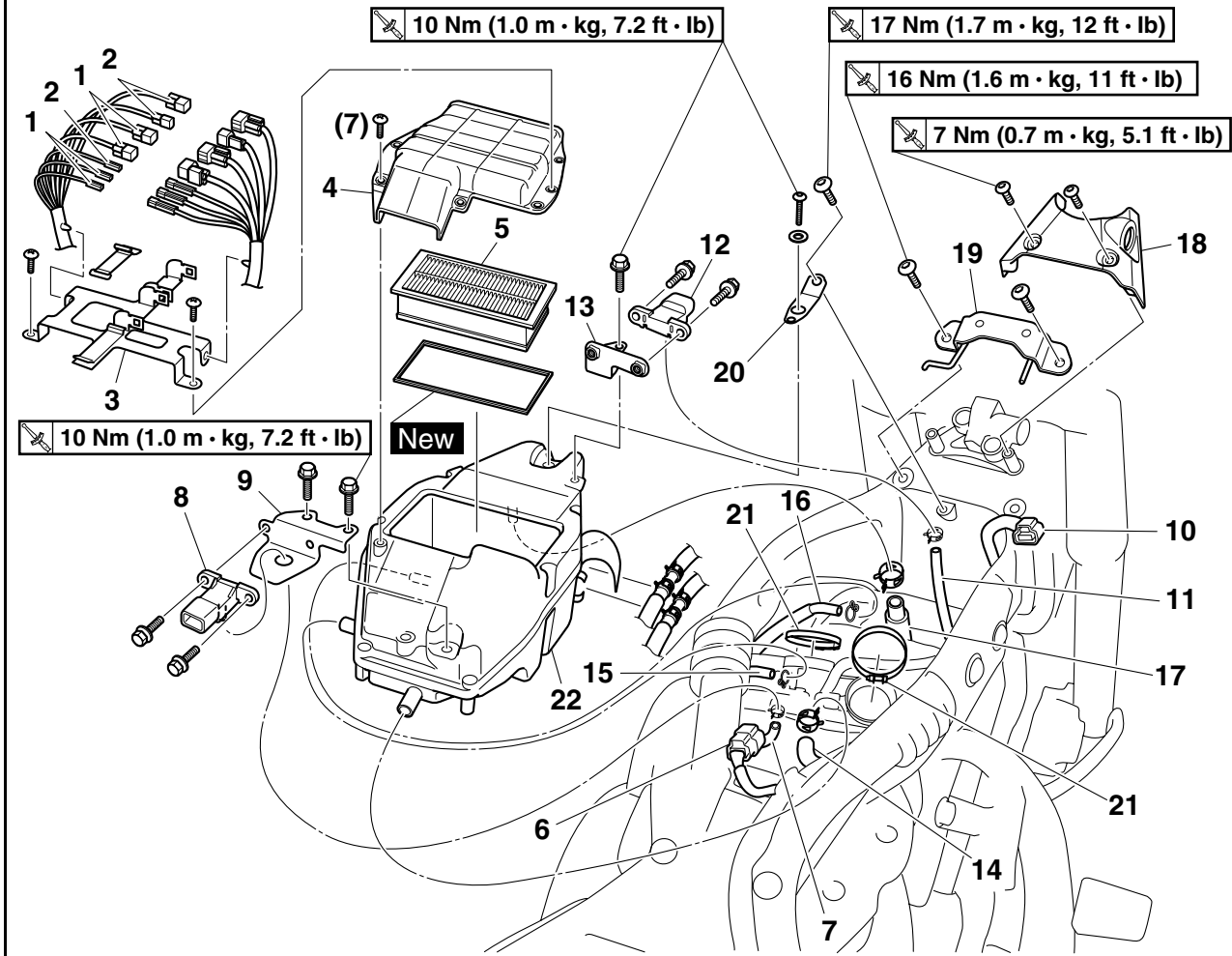

Order	Job/Parts to remove	Q'ty	Remarks
	Rider seat		Refer to "GENERAL CHASSIS" on page 4-1.
	Fuel tank		Refer to "FUEL TANK" on page 6-1.
	Pressure regulator cover		Refer to "THROTTLE BODIES" on page 6-7.
1	Left handlebar switch coupler	4	Disconnect.
2	Right handlebar switch coupler	3	Disconnect.
3	Coupler holder	1	
4	Air filter case cover	1	
5	Air filter element	1	
6	Cylinder-#1 intake air pressure sensor coupler	1	Disconnect.
7	Cylinder-#1 intake air pressure sensor hose	1	Disconnect.
8	Cylinder-#1 intake air pressure sensor	1	
9	Cylinder-#1 intake air pressure sensor bracket	1	
10	Cylinder-#2 intake air pressure sensor coupler	1	Disconnect.
11	Cylinder-#2 intake air pressure sensor hose	1	Disconnect.
12	Cylinder-#2 intake air pressure sensor	1	
13	Cylinder-#2 intake air pressure sensor bracket	1	
14	Cylinder head breather hose	1	Disconnect.

Removing the air filter case (for XV19CS(C)/ XV19C(C))

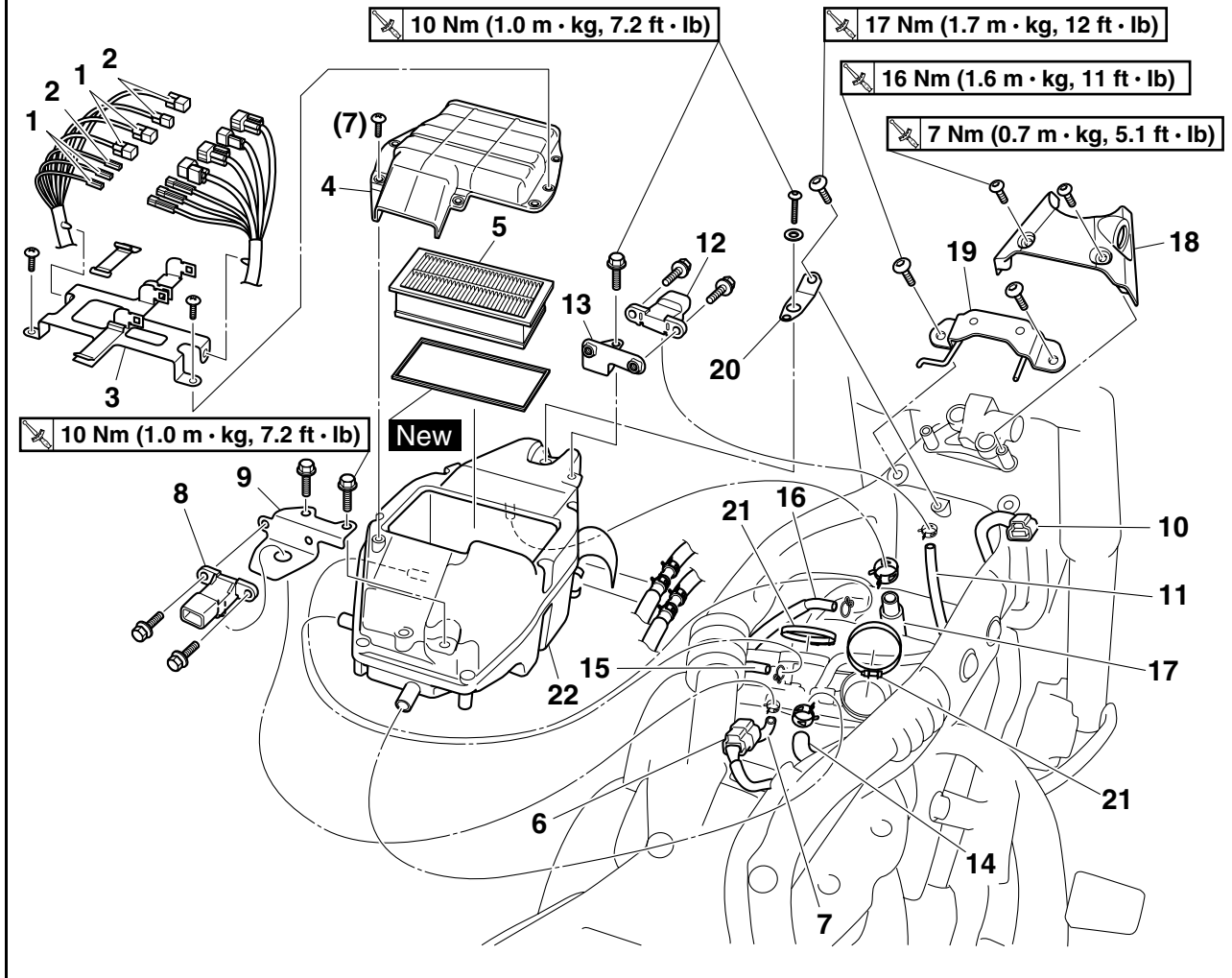

Order	Job/Parts to remove	Q'ty	Remarks
15	Air filter case breather hose 1	1	Disconnect.
16	Air filter case breather hose 2	1	Disconnect.
17	ISC (idle speed control) unit inlet hose	1	Disconnect.
18	Steering lock cover	1	
19	Fuel tank bracket 2 (front side)	1	
20	Air filter case bracket	1	
21	Air filter case joint clamp screw	2	Loosen.
22	Air filter case	1	
			For installation, reverse the removal procedure.

EAS21870

FRONT WHEEL

Removing the front wheel and brake discs (for XV19S(C)/ XV19M(C)/ XV19CTS(C)/ XV19CTM(C))

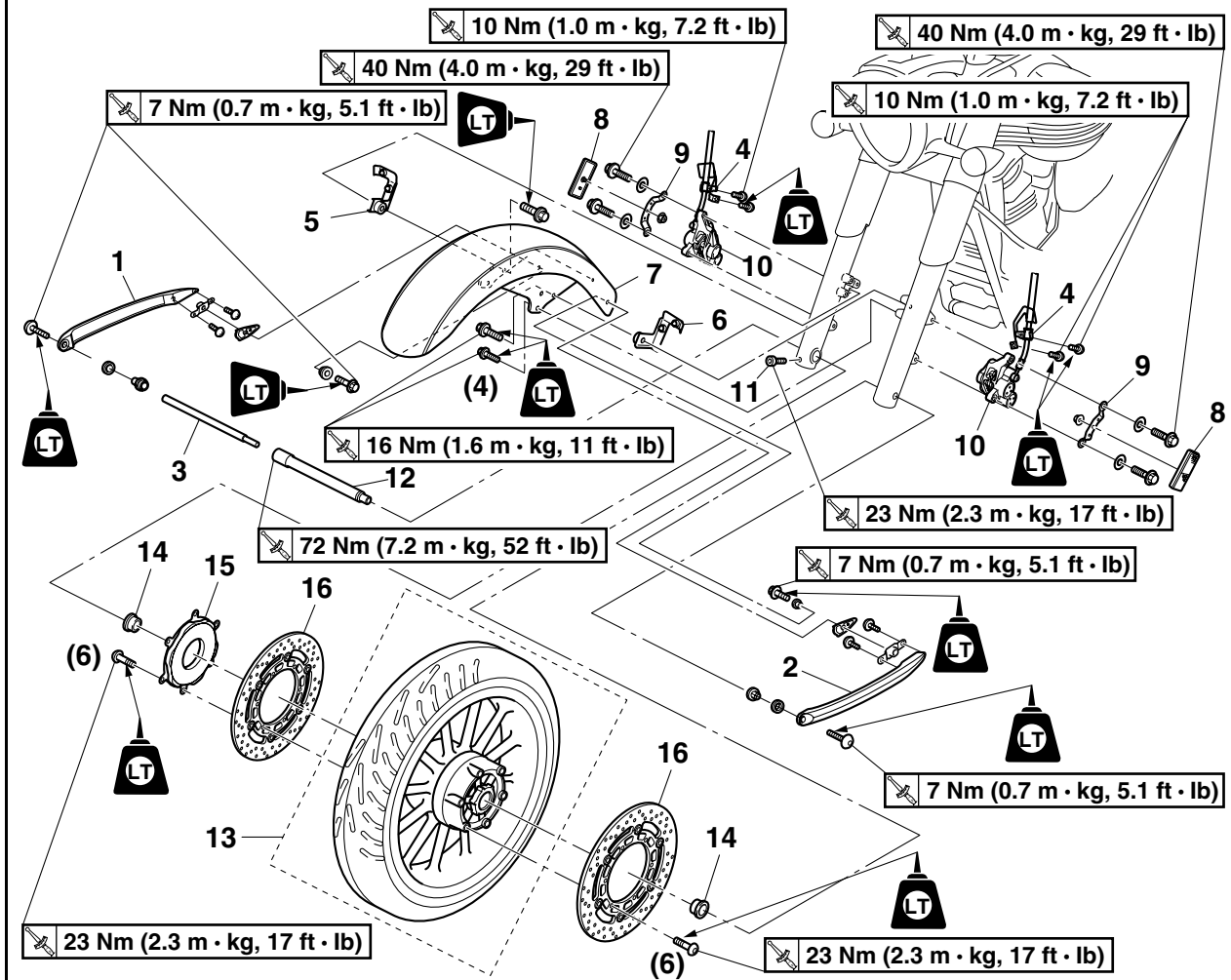

Order	Job/Parts to remove	Q'ty	Remarks
			NOTE: _____ Place the vehicle on a suitable stand so that the front wheel is elevated.
1	Right front fender stay	1	
2	Left front fender stay	1	
3	Front fender stay rod	1	
4	Front brake hose guide	2	
5	Right front brake hose guide bracket	1	
6	Left front brake hose guide bracket	1	
7	Front fender	1	
8	Reflector	2	
9	Reflector bracket	2	
10	Front brake caliper	2	
11	Front wheel axle pinch bolt	1	Loosen.
12	Front wheel axle	1	
13	Front wheel	1	

FRONT WHEEL

Removing the front wheel and brake discs (for XV19S(C)/ XV19M(C)/ XV19CTS(C)/ XV19CTM(C))

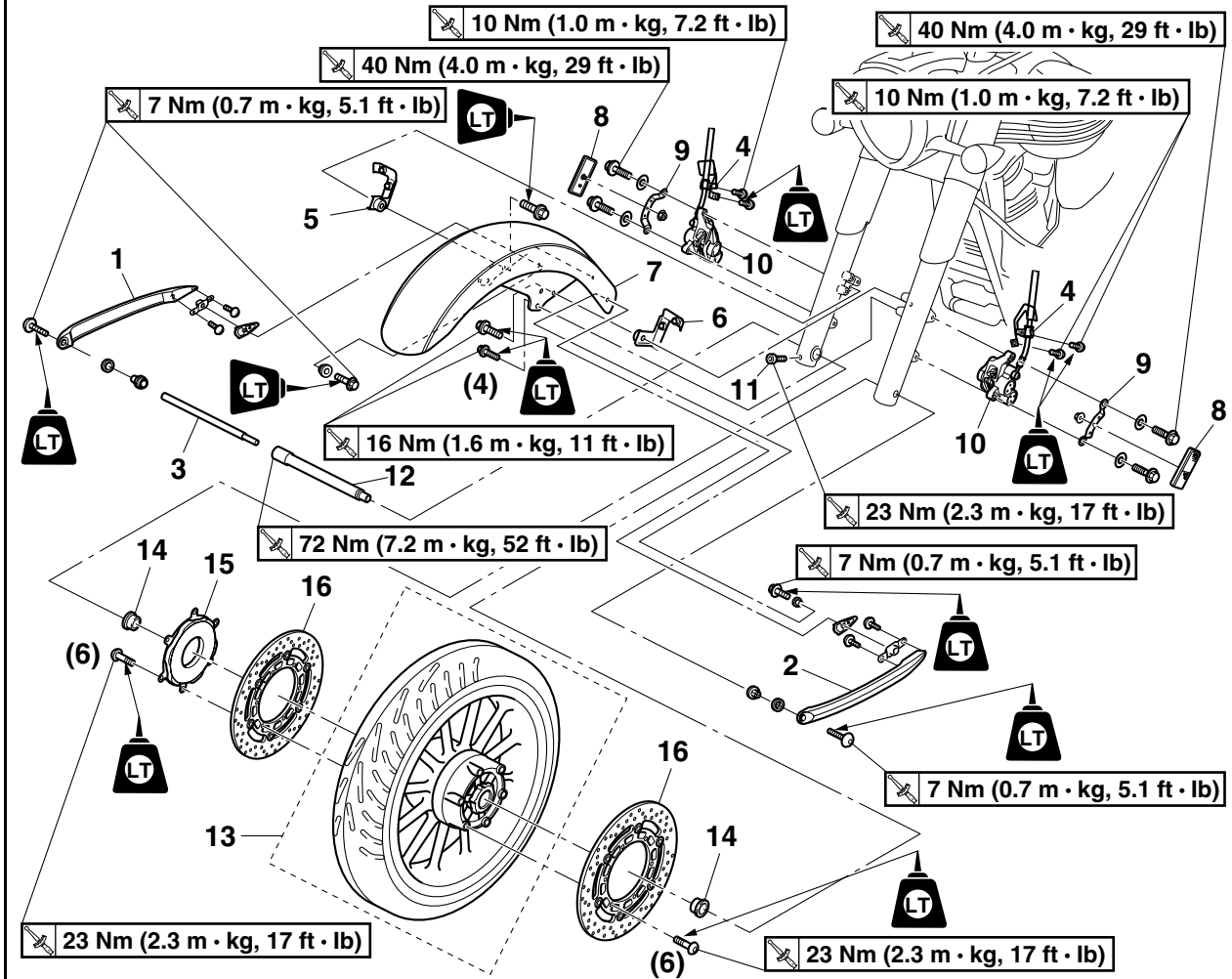

Order	Job/Parts to remove	Q'ty	Remarks
14	Collar	2	
15	Front brake disc cover	1	
16	Front brake disc	2	
			For installation, reverse the removal procedure.

FRONT WHEEL

Removing the front wheel and brake discs (for XV19CS(C)/ XV19C(C))

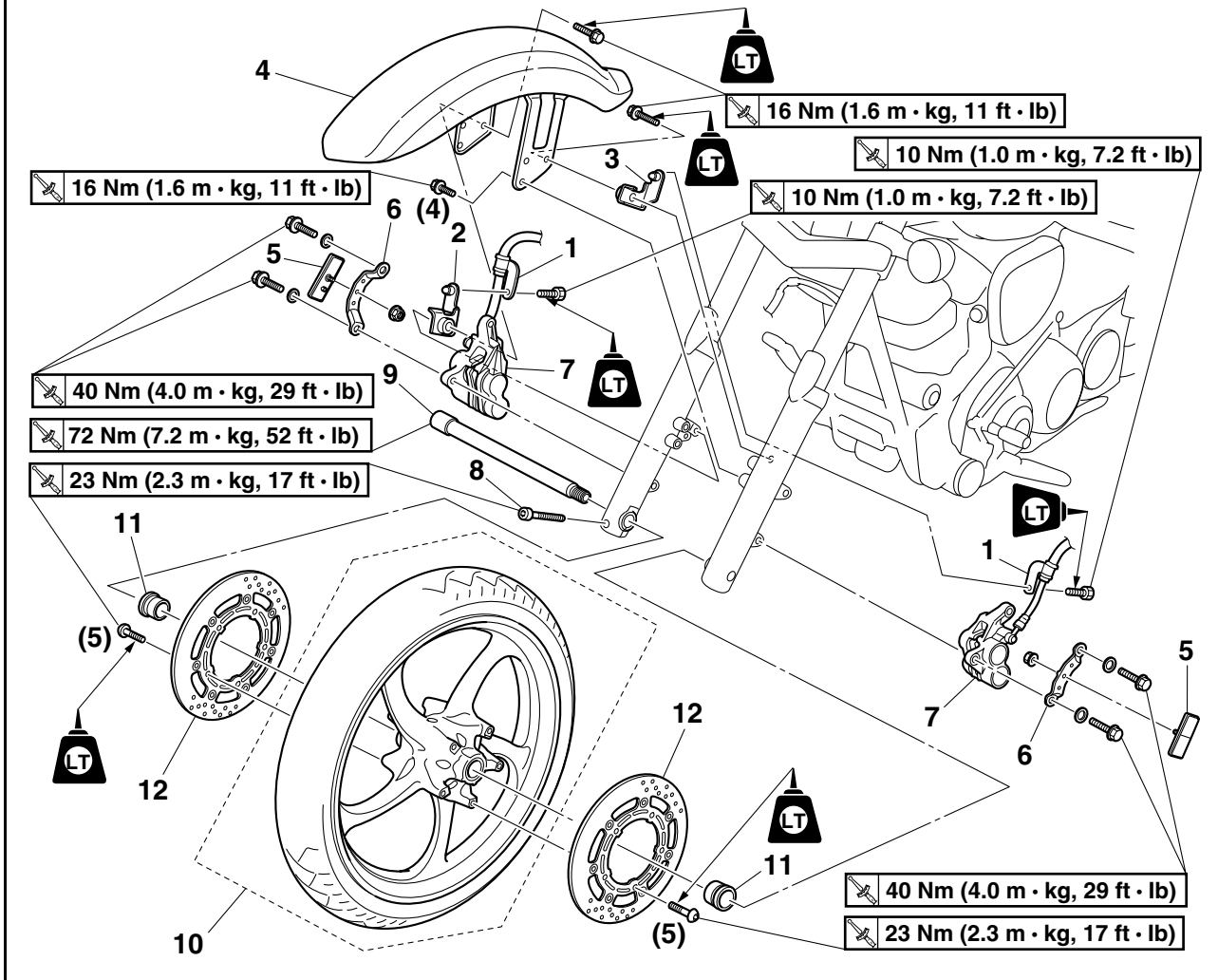

Order	Job/Parts to remove	Q'ty	Remarks
			NOTE: _____ Place the vehicle on a suitable stand so that the front wheel is elevated.
1	Front brake hose holder	2	
2	Right front brake hose holder bracket	1	
3	Left front brake hose holder bracket	1	
4	Front fender	1	
5	Reflector	2	
6	Reflector bracket	2	
7	Front brake caliper	2	
8	Front wheel axle pinch bolt	1	Loosen.
9	Front wheel axle	1	
10	Front wheel	1	
11	Collar	2	
12	Front brake disc	2	
			For installation, reverse the removal procedure.

Disassembling the front wheel

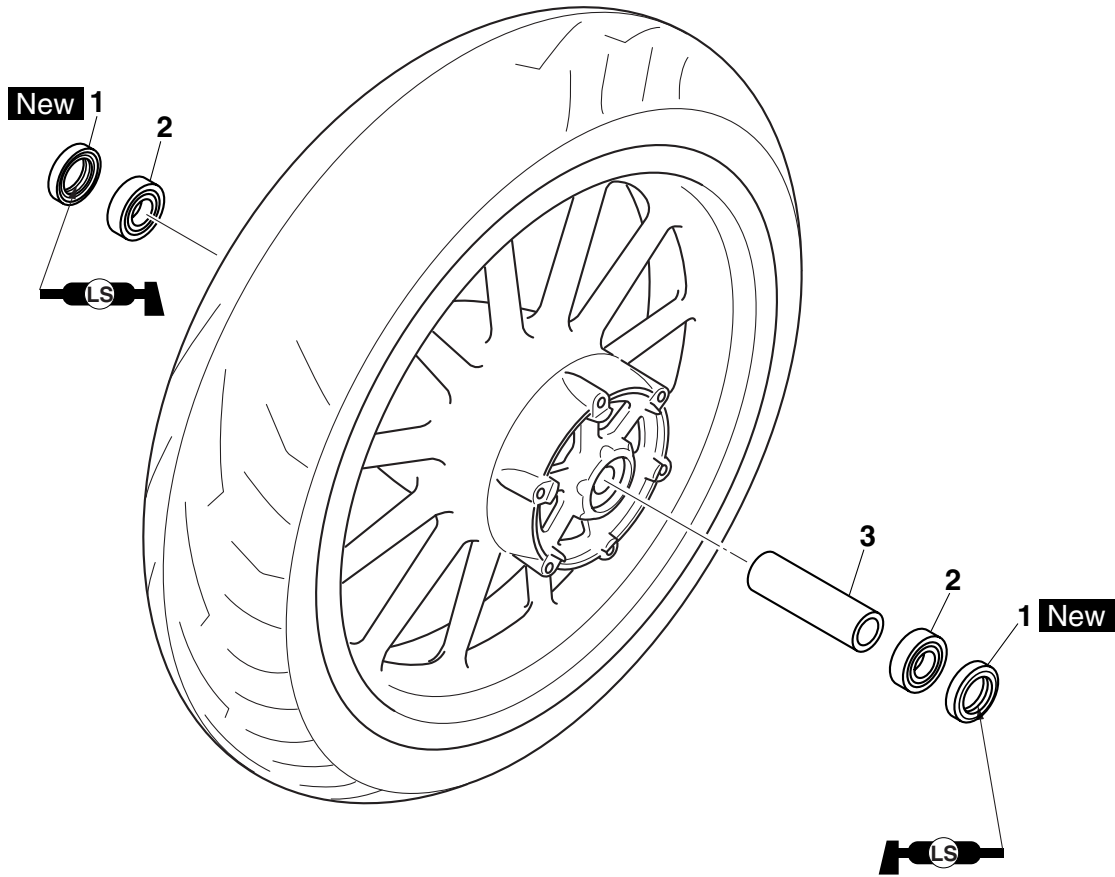

Order	Job/Parts to remove	Q'ty	Remarks
1	Oil seal	2	
2	Wheel bearing	2	
3	Spacer	1	
			For assembly, reverse the disassembly procedure.

EAS21900

REMOVING THE FRONT WHEEL

- Stand the vehicle on a level surface.

EWA13120

WARNING

Securely support the vehicle so that there is no danger of it falling over.

- Remove: (for XV19S(C)/ XV19M(C)/ XV19CTS(C)/ XV19CTM(C))
 - Right front fender stay “1”
 - Left front fender stay “2”
 - Front fender stay rod “3”

NOTE:

- Remove the right front fender stay bolts and left front fender stay bolt (rear side), then hold the rod with a wrench “4” and remove the left front fender stay bolt (front side) “5”.
- Remove the rod from the right side of the vehicle.

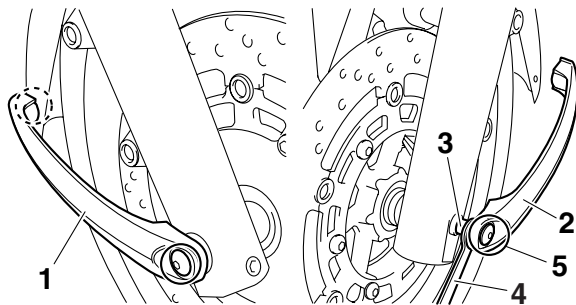

- Loosen:

- Front wheel axle pinch bolt “1”

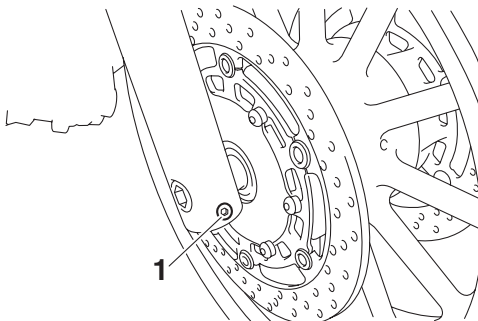

- Remove:

- Front brake calipers

NOTE:

Do not apply the brake lever when removing the brake calipers.

- Elevate:

- Front wheel

NOTE:

Place the vehicle on a suitable stand so that the front wheel is elevated.

EAS21910

DISASSEMBLING THE FRONT WHEEL

- Remove:

- Oil seals
- Wheel bearings



- Clean the outside of the front wheel hub.
- Remove the oil seals “1” with a flathead screwdriver.

NOTE:

To prevent damaging the wheel, place a rag “2” between the screwdriver and the wheel surface.

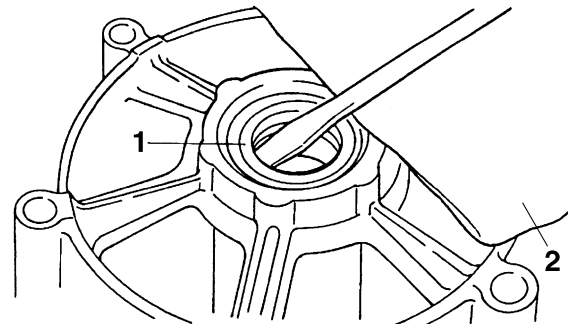

- Remove the wheel bearings “3” with a general bearing puller.

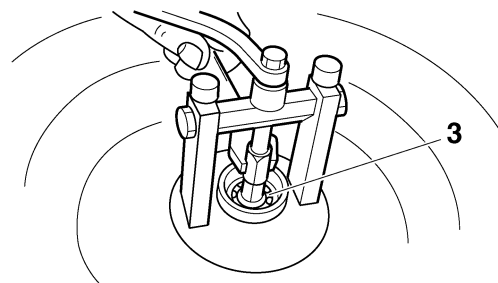

EAS21920

CHECKING THE FRONT WHEEL

- Check:

- Front wheel axle
Roll the wheel axle on a flat surface.
Bends → Replace.

EWA13460

WARNING

Do not attempt to straighten a bent wheel axle.

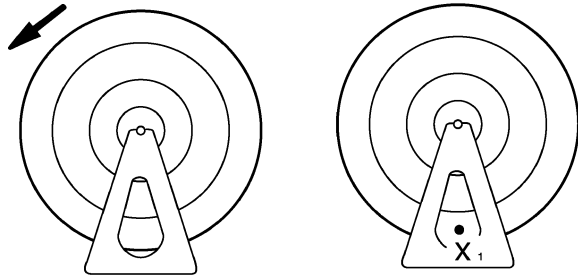

- c. Turn the front wheel 90° so that the “X₁” mark is positioned as shown.
- d. Release the front wheel.
- e. When the wheel stops, put an “X₂” mark at the bottom of the wheel.

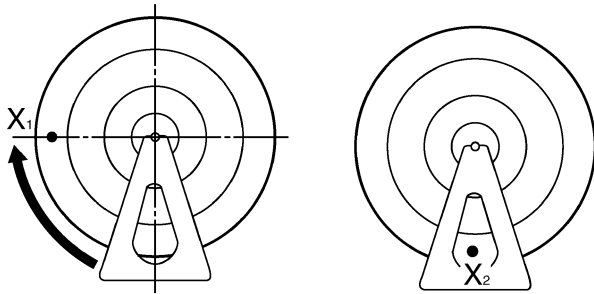

- f. Repeat steps (d) through (f) several times until all the marks come to rest at the same spot.
- g. The spot where all the marks come to rest is the front wheel’s heavy spot “X”.



3. Adjust:
 - Front wheel static balance



- a. Install a balancing weight “1” onto the rim exactly opposite the heavy spot “X”.

NOTE: _____

Start with the lightest weight.

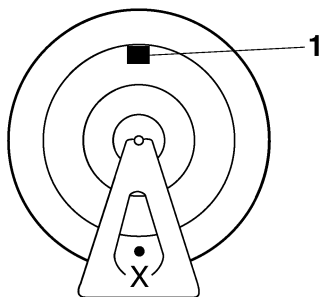

- b. Turn the front wheel 90° so that the heavy spot is positioned as shown.

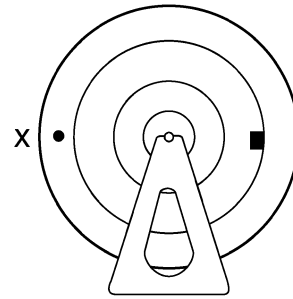

- c. If the heavy spot does not stay in that position, install a heavier weight.
- d. Repeat steps (b) and (c) until the front wheel is balanced.



4. Check:
 - Front wheel static balance



- a. Turn the front wheel and make sure it stays at each position shown.

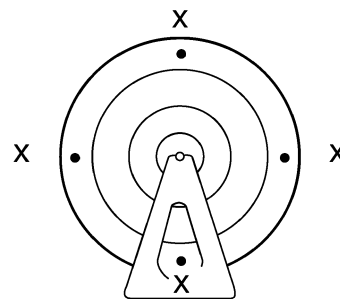

- b. If the front wheel does not remain stationary at all of the positions, rebalance it.



EAS22000

INSTALLING THE FRONT WHEEL (FRONT BRAKE DISCS)

The following procedure applies to both of the front brake discs.

1. Install:
 - Front brake disc
 - Front brake disc cover

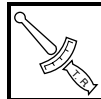

Front brake disc bolt
23 Nm (2.3 m·kg, 17 ft·lb)
LOCTITE®

NOTE: _____

Tighten the front brake disc bolts in stages and in a crisscross pattern.

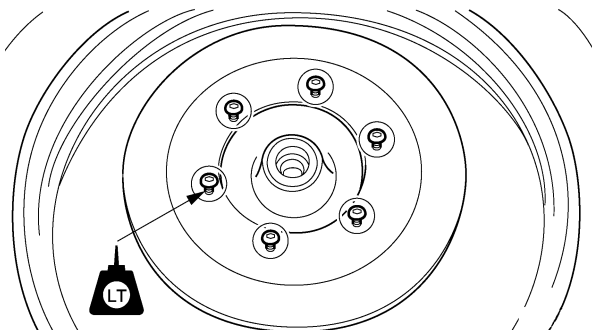

2. Check:

- Front brake discs

Refer to “CHECKING THE FRONT BRAKE DISCS” on page 4-40.

3. Lubricate:

- Oil seal lips



4. Install:

- Front wheel axle

NOTE:

Install the tire and wheel with the mark “1” pointing in the direction of wheel rotation.

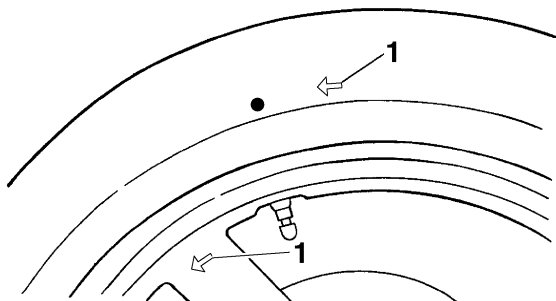

5. Tighten:

- Front wheel axle
- Front wheel axle pinch bolt

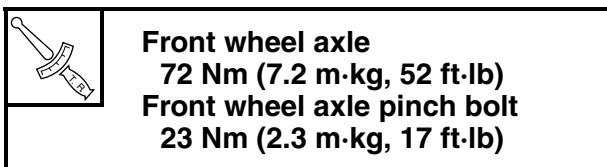

EC1D71004

CAUTION:

Before tightening the wheel axle, push down hard on the handlebar several times and check if the front fork rebounds smoothly.

6. Install:

- Front brake calipers



Front brake caliper bolt
40 Nm (4.0 m·kg, 29 ft·lb)

EWA13500

WARNING

Make sure the brake hose is routed properly.

7. Install:

- Front fender
- Left front brake hose guide bracket
- Right front brake hose guide bracket

NOTE:

- Temporarily tighten the front fender bolts.
- Apply locking agent (LOCTITE®) to the threads of the front fender bolts.

8. Install: (for XV19S(C)/ XV19M(C)/ XV19CTS(C)/ XV19CTM(C))

- Front fender stay rod “1”
- Left front fender stay “2”
- Right front fender stay “3”

NOTE:

- Insert the rod into the front wheel axle from the right side of the vehicle.
- Tighten the left front fender stay bolt (front side) “4” to specification while holding the rod with a wrench “5”, and then tighten the left front fender stay bolt (rear side) and right front fender stay bolts to specification.

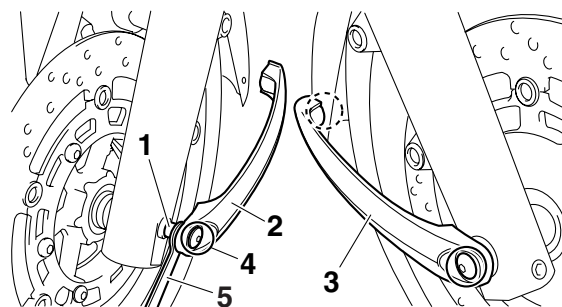

9. Tighten:

- Front fender bolts



Front fender bolt
16 Nm (1.6 m·kg, 11 ft·lb)
LOCTITE®

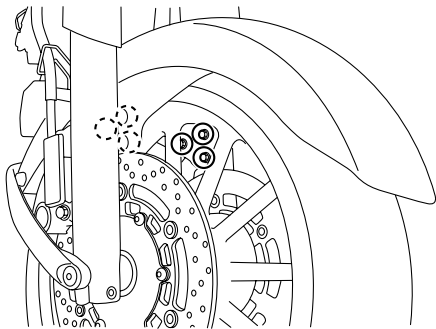

EAS22020

REAR WHEEL

Removing the rear fender

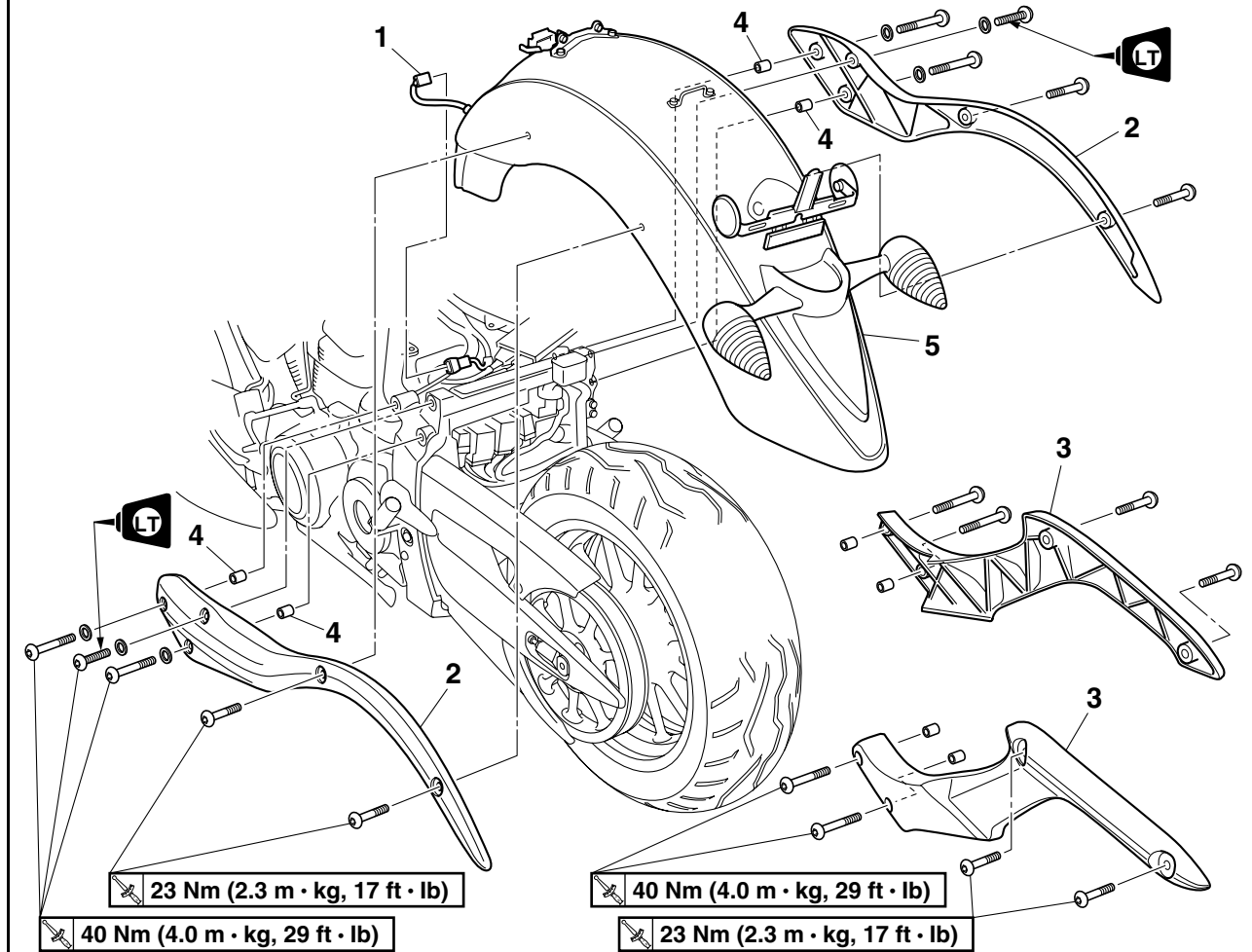

Order	Job/Parts to remove	Q'ty	Remarks
	Rider seat/Passenger seat/Tool kit tray		Refer to "GENERAL CHASSIS" on page 4-1.
1	Sub-wire harness 1 coupler	1	Disconnect.
2	Rear fender bracket	2	For XV19S(C)/ XV19M(C)/ XV19CTS(C)/ XV19CTM(C)
3	Rear fender bracket	2	For XV19CS(C)/ XV19C(C)
4	Dowel pin	4	
5	Rear fender assembly	1	
			For installation, reverse the removal procedure.

REAR WHEEL

Removing the rear wheel

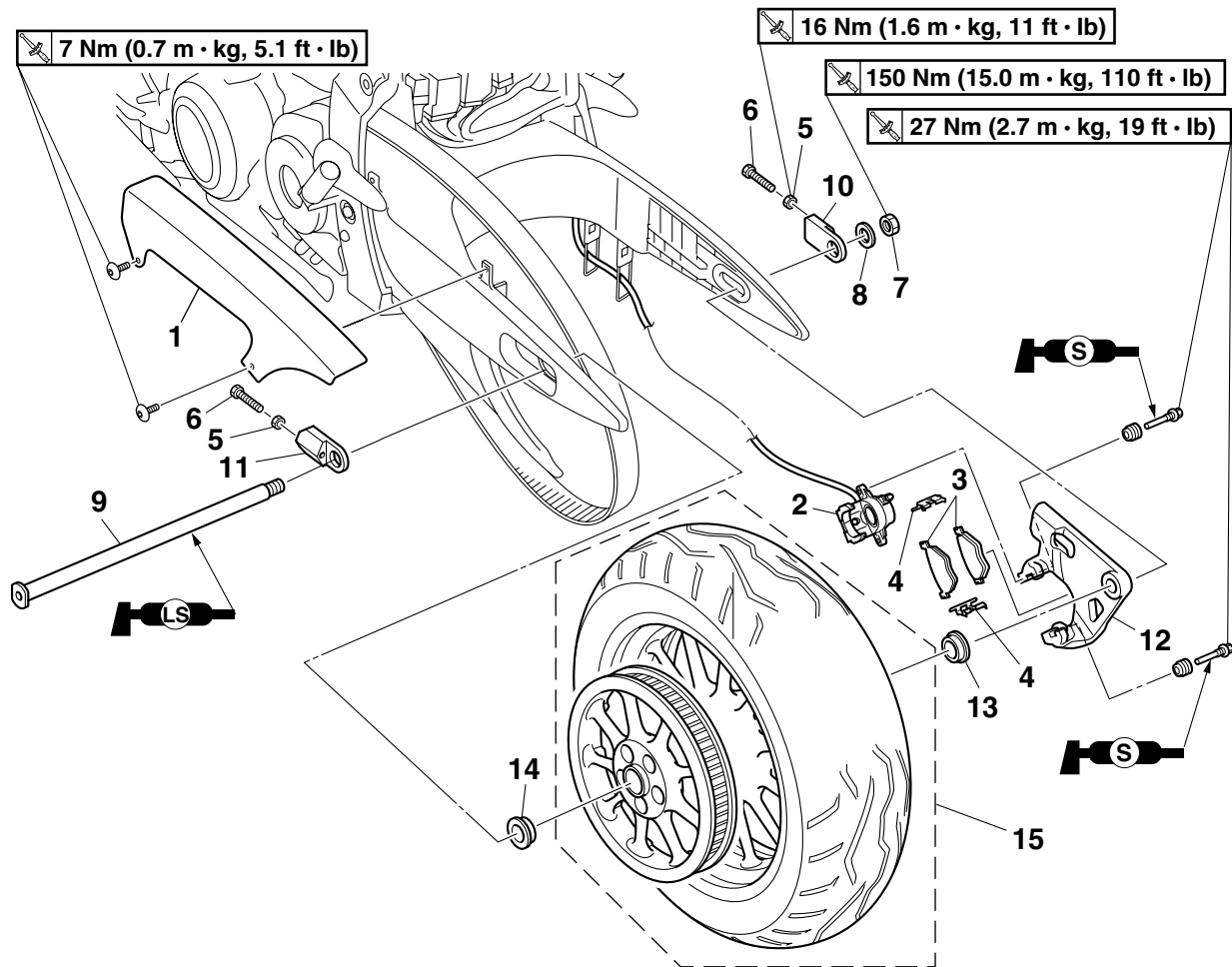

Order	Job/Parts to remove	Q'ty	Remarks
			NOTE: _____ Place the vehicle on a suitable stand so that the rear wheel is elevated.
	Muffler		Refer to "ENGINE REMOVAL" on page 5-1.
1	Upper drive belt cover	1	
2	Rear brake caliper	1	
3	Rear brake pad	2	
4	Brake pad spring	2	
5	Drive belt adjusting locknut	2	Loosen.
6	Drive belt adjusting bolt	2	Loosen.
7	Rear wheel axle nut	1	
8	Washer	1	
9	Rear wheel axle	1	
10	Right drive belt puller	1	
11	Left drive belt puller	1	
12	Rear brake caliper bracket	1	
13	Collar	1	Black

REAR WHEEL

Removing the rear wheel

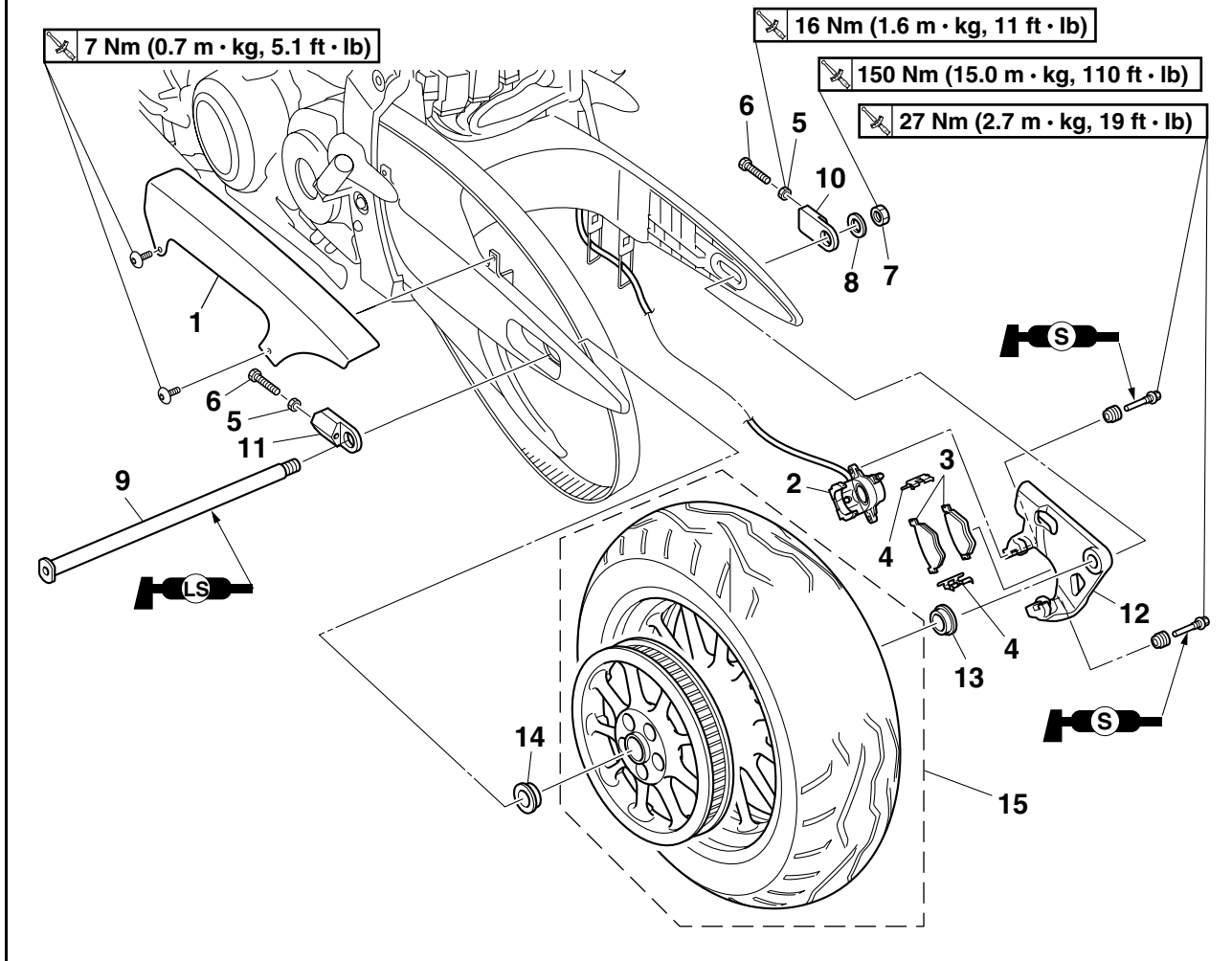

Order	Job/Parts to remove	Q'ty	Remarks
14	Collar	1	Silver
15	Rear wheel	1	
			For installation, reverse the removal procedure.

REAR WHEEL

Removing the rear brake disc and rear wheel drive hub

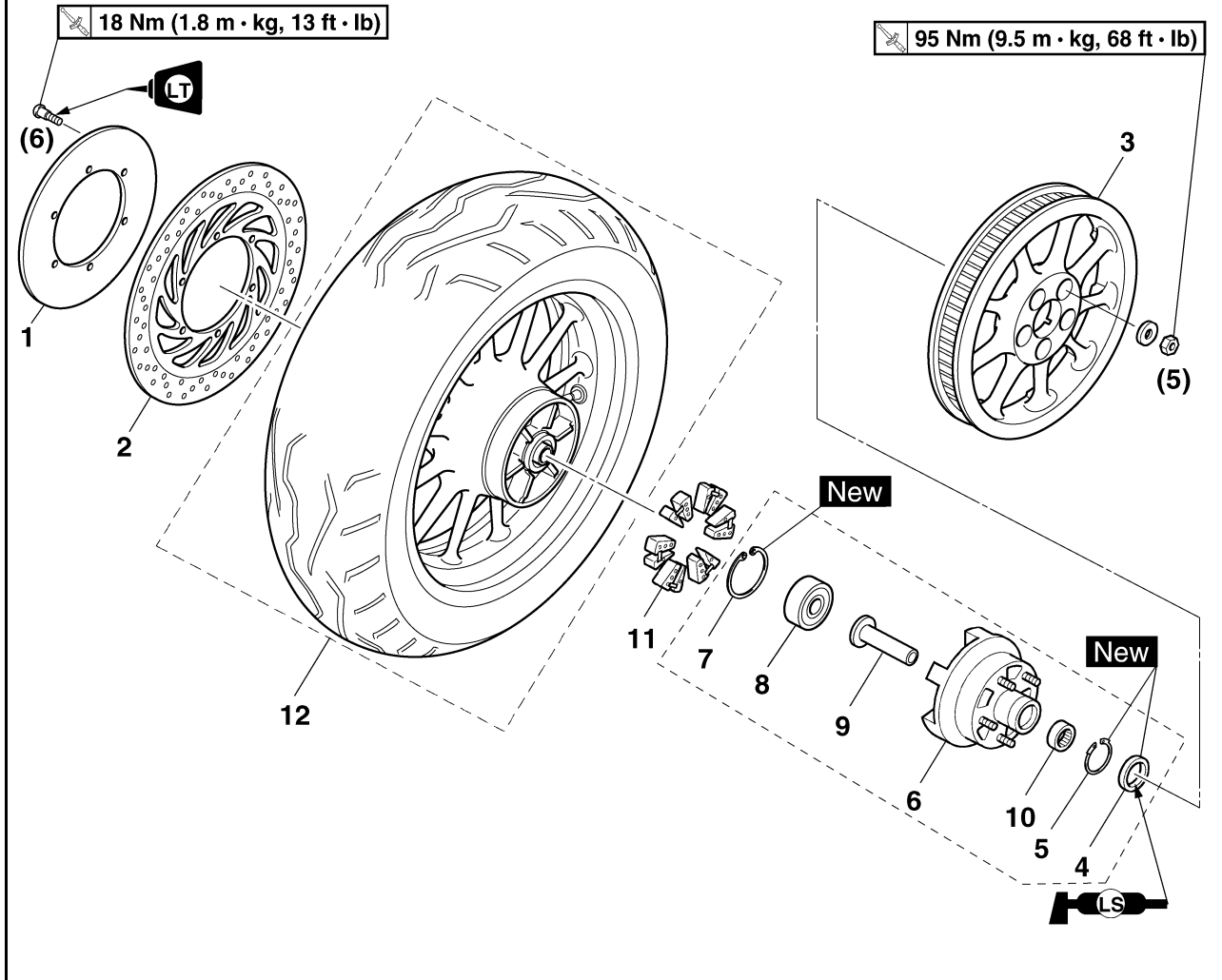

Order	Job/Parts to remove	Q'ty	Remarks
1	Rear brake disc cover	1	
2	Rear brake disc	1	
3	Rear wheel pulley	1	
4	Oil seal	1	
5	Circlip	1	
6	Rear wheel drive hub	1	
7	Circlip	1	
8	Bearing	1	
9	Collar	1	
10	Bearing	1	
11	Rear wheel drive hub damper	6	
12	Rear wheel	1	
			For installation, reverse the removal procedure.

Disassembling the rear wheel

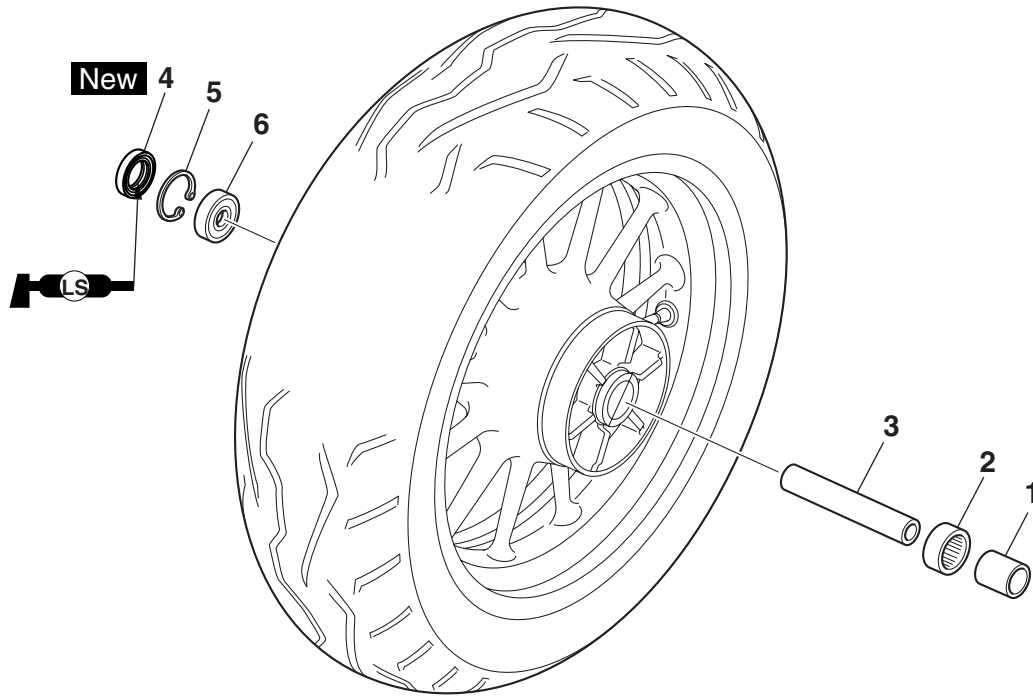

Order	Job/Parts to remove	Q'ty	Remarks
1	Collar	1	
2	Bearing	1	
3	Spacer	1	
4	Oil seal	1	
5	Circlip	1	
6	Bearing	1	
			For assembly, reverse the disassembly procedure.

EAS28760

REMOVING THE REAR WHEEL (DISC)

1. Stand the vehicle on a level surface.

EWA13120

WARNING

Securely support the vehicle so that there is no danger of it falling over.

NOTE:

Place the vehicle on a suitable stand so that the rear wheel is elevated.

2. Remove:

- Rear brake caliper "1"

NOTE:

Do not depress the brake pedal when removing the brake caliper.

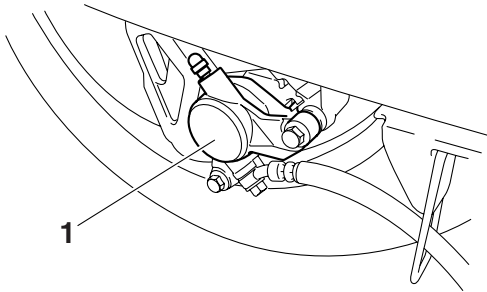

3. Loosen:

- Drive belt adjusting locknuts "1"
- Drive belt adjusting bolts "2"

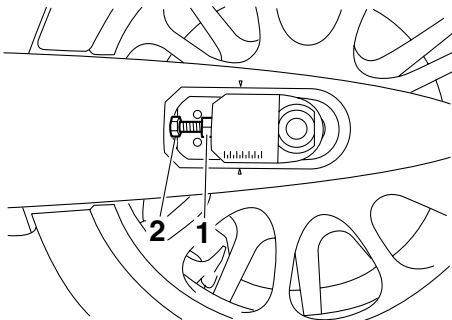

4. Remove:

- Rear wheel axle nut "1"
- Rear wheel axle "2"
- Rear wheel

NOTE:

Push the rear wheel forward and remove the drive belt from the rear wheel pulley.

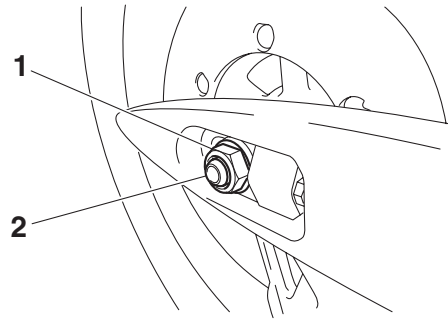

EAS22080

DISASSEMBLING THE REAR WHEEL

1. Remove:

- Oil seals
- Wheel bearings

Refer to "DISASSEMBLING THE FRONT WHEEL" on page 4-22.

EAS22090

CHECKING THE REAR WHEEL

1. Check:

- Rear wheel axle
- Rear wheel
- Wheel bearings
- Oil seals

Refer to "CHECKING THE FRONT WHEEL" on page 4-22.

2. Check:

- Tire
- Rear wheel

Damage/wear → Replace.

Refer to "CHECKING THE TIRES" on page 3-29 and "CHECKING THE WHEELS" on page 3-31.

3. Measure:

- Radial wheel runout
- Lateral wheel runout

Refer to "CHECKING THE FRONT WHEEL" on page 4-22.



**Radial wheel runout limit
1.0 mm (0.04 in)
Lateral wheel runout limit
0.5 mm (0.02 in)**

ET1D71024

CHECKING THE REAR BRAKE CALIPER BRACKET

1. Check:

- Rear brake caliper bracket
- Cracks/damage → Replace.

NOTE:

Temporarily tighten the wheel axle nut.

5. Adjust:

- Drive belt slack

Refer to “ADJUSTING THE DRIVE BELT SLACK” on page 3-26.

6. Tighten:

- Rear wheel axle nut



Rear wheel axle nut
150 Nm (15.0 m·kg, 110 ft·lb)

7. Install:

- Rear brake caliper



Rear brake caliper
27 Nm (2.7 m·kg, 19 ft·lb)

EWA13500



Make sure the brake hose is routed properly.

EAS22210

FRONT BRAKE

Removing the front brake pads

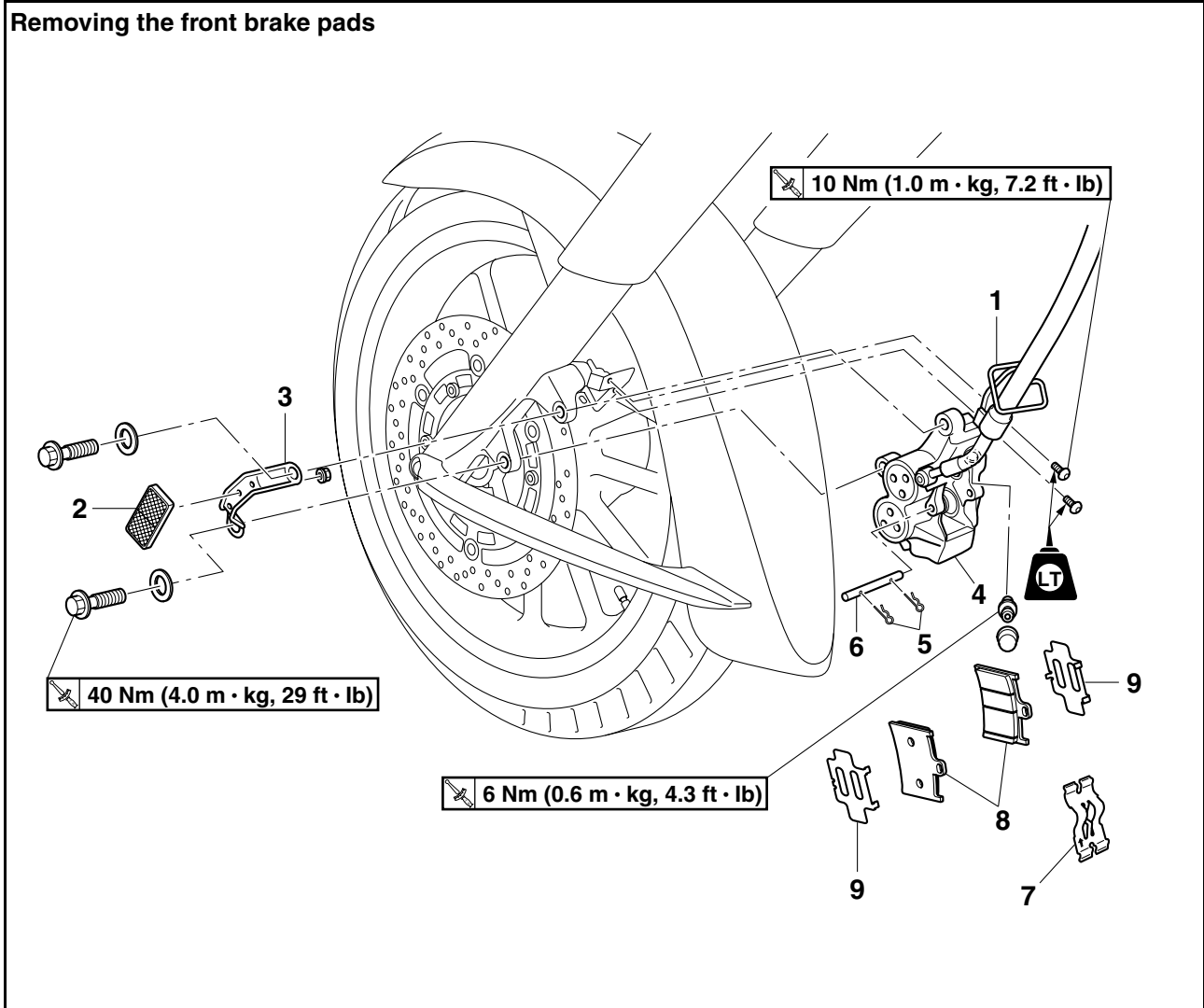

Order	Job/Parts to remove	Q'ty	Remarks
			The following procedure applies to both of the front brake calipers.
1	Brake hose holder	1	
2	Reflector	1	
3	Reflector bracket	1	
4	Front brake caliper	1	
5	Brake pad clip	2	
6	Brake pad pin	1	
7	Brake pad spring	1	
8	Brake pad	2	
9	Brake pad shim	2	
			For installation, reverse the removal procedure.

Removing the front brake master cylinder

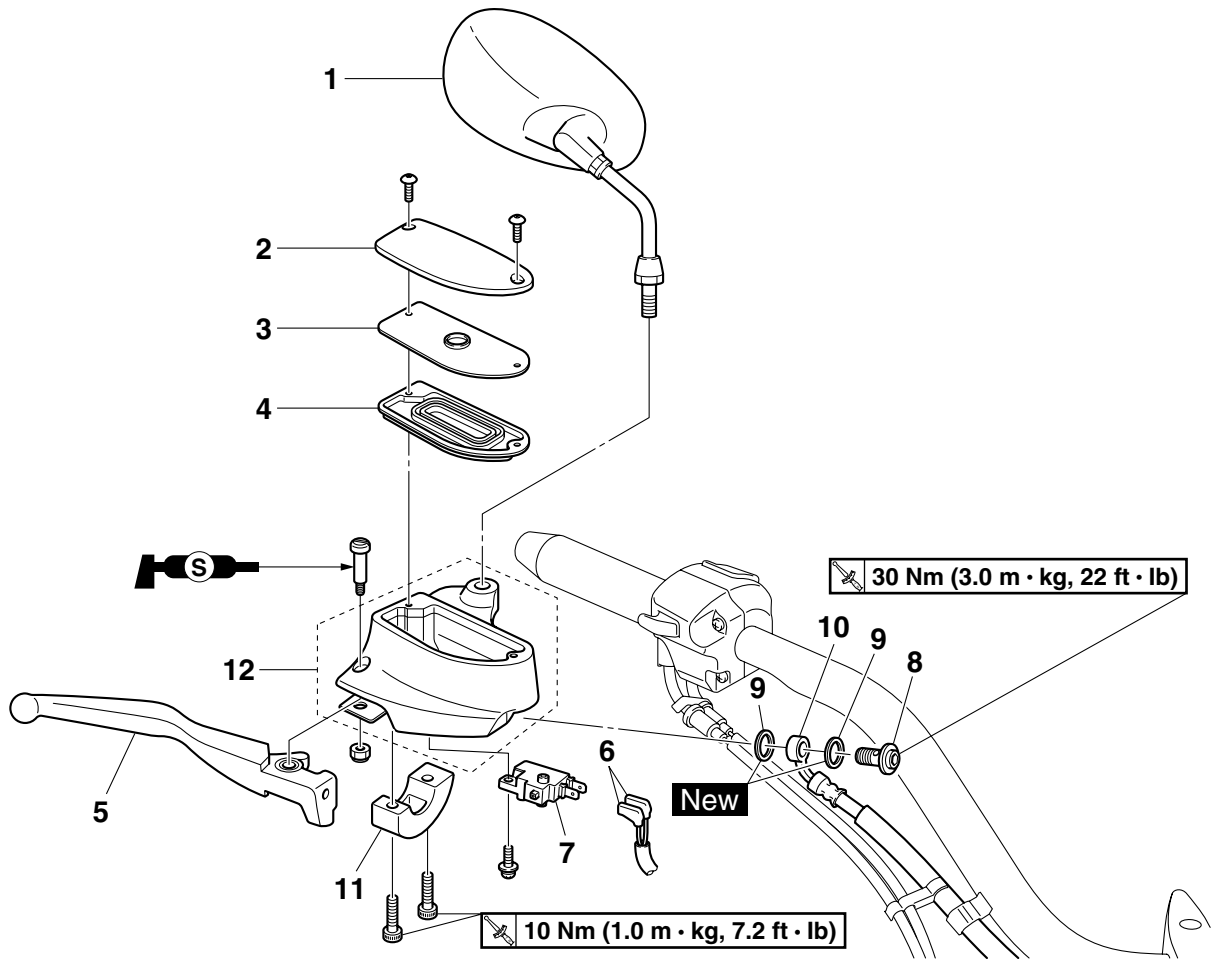

Order	Job/Parts to remove	Q'ty	Remarks
	Brake fluid		Drain. Refer to "BLEEDING THE HYDRAULIC BRAKE SYSTEM" on page 3-24.
1	Right rearview mirror	1	
2	Brake master cylinder reservoir cap	1	
3	Brake master cylinder reservoir diaphragm holder	1	
4	Brake master cylinder reservoir diaphragm	1	
5	Brake lever	1	
6	Brake light switch connector	2	Disconnect.
7	Brake light switch	1	
8	Front brake hose union bolt	1	
9	Copper washer	2	
10	Front brake hose	1	
11	Front brake master cylinder holder	1	
12	Front brake master cylinder	1	
			For installation, reverse the removal procedure.

Disassembling the front brake master cylinder

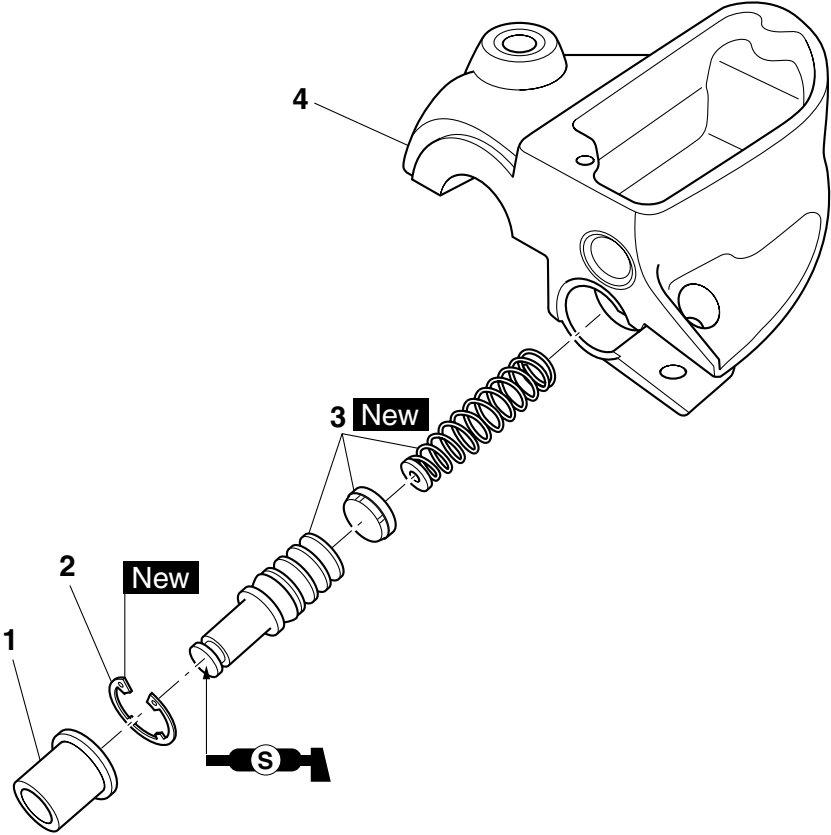

Order	Job/Parts to remove	Q'ty	Remarks
1	Dust boot	1	
2	Circlip	1	
3	Brake master cylinder kit	1	
4	Brake master cylinder body	1	
			For assembly, reverse the disassembly procedure.

FRONT BRAKE

Removing the front brake calipers

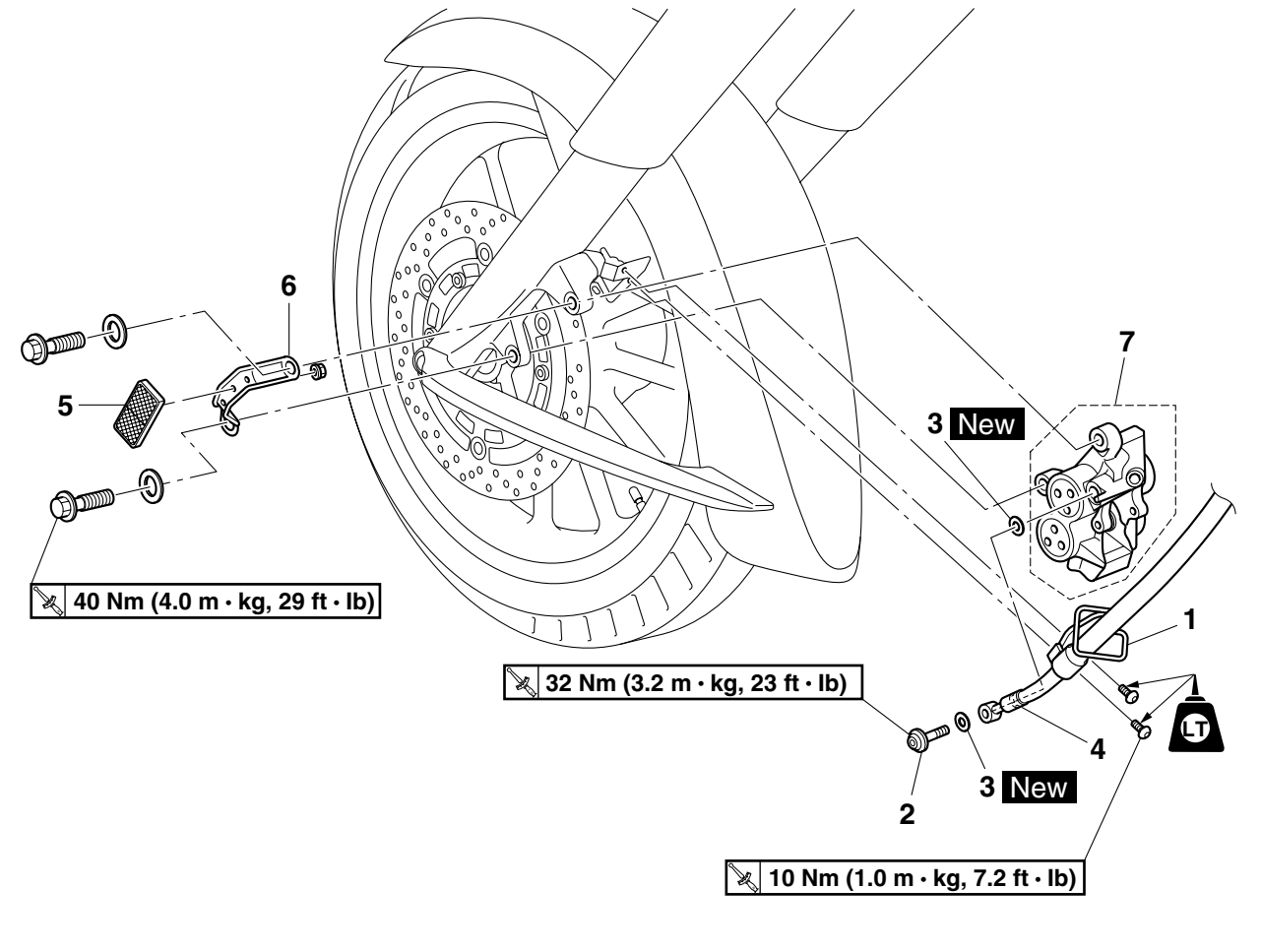

Order	Job/Parts to remove	Q'ty	Remarks
			The following procedure applies to both of the front brake calipers.
	Brake fluid		Drain. Refer to "BLEEDING THE HYDRAULIC BRAKE SYSTEM" on page 3-24.
1	Brake hose holder	1	
2	Front brake hose union bolt	1	
3	Copper washer	2	
4	Front brake hose	1	
5	Reflector	1	
6	Reflector bracket	1	
7	Front brake caliper	1	
			For installation, reverse the removal procedure.

FRONT BRAKE

Disassembling the front brake calipers

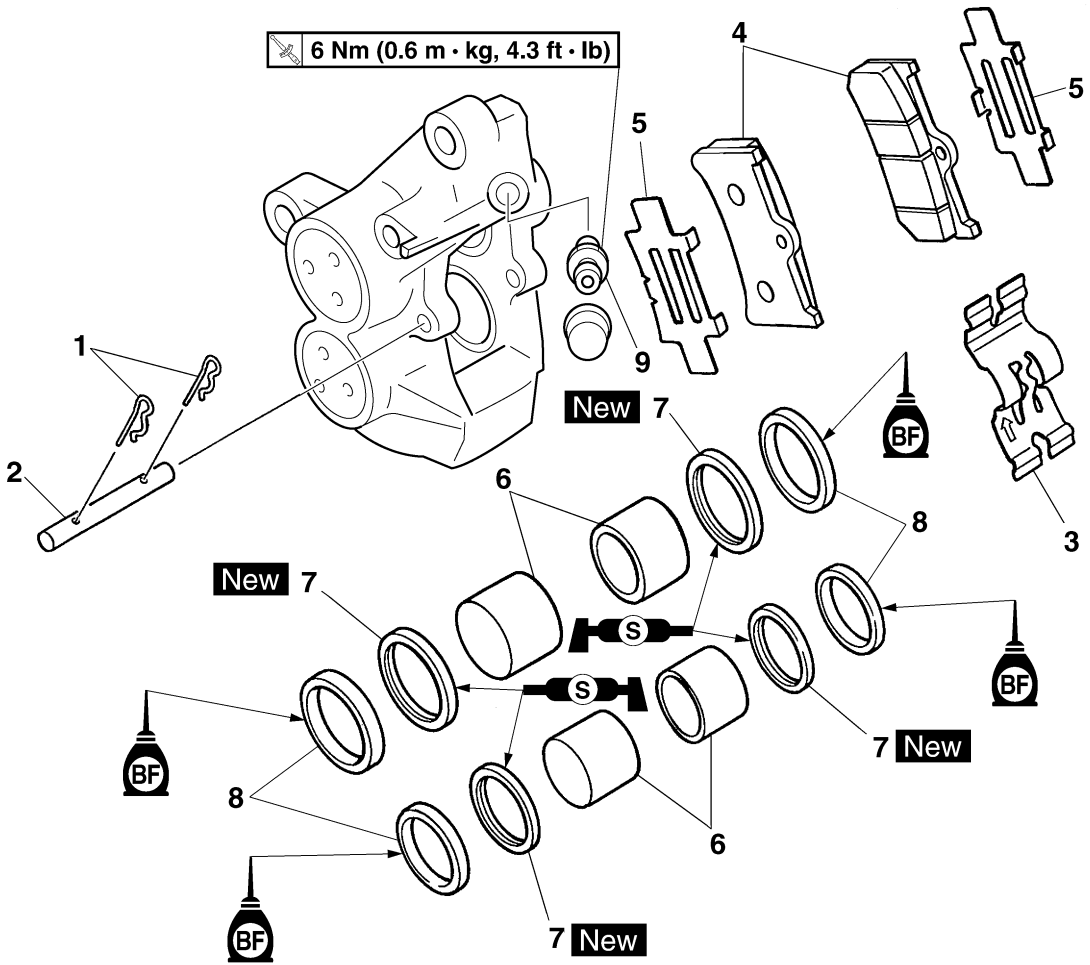

Order	Job/Parts to remove	Q'ty	Remarks
			The following procedure applies to both of the front brake calipers.
1	Brake pad clip	2	
2	Brake pad pin	1	
3	Brake pad spring	1	
4	Brake pad	2	
5	Brake pad shim	2	
6	Brake caliper piston	4	
7	Brake caliper piston dust seal	4	
8	Brake caliper piston seal	4	
9	Bleed screw	1	
			For assembly, reverse the disassembly procedure.

EAS22220

INTRODUCTION

EWA14100

WARNING

Disc brake components rarely require disassembly. Therefore, always follow these preventive measures:

- Never disassemble brake components unless absolutely necessary.
- If any connection on the hydraulic brake system is disconnected, the entire brake system must be disassembled, drained, cleaned, properly filled, and bled after reassembly.
- Never use solvents on internal brake components.
- Use only clean or new brake fluid for cleaning brake components.
- Brake fluid may damage painted surfaces and plastic parts. Therefore, always clean up any spilt brake fluid immediately.
- Avoid brake fluid coming into contact with the eyes as it can cause serious injury.
- **FIRST AID FOR BRAKE FLUID ENTERING THE EYES:**
- Flush with water for 15 minutes and get immediate medical attention.

EAS22240

CHECKING THE FRONT BRAKE DISCS

The following procedure applies to both brake discs.

1. Remove:
 - Front wheel
Refer to "FRONT WHEEL" on page 4-18.
2. Check:
 - Brake disc
Damage/galling → Replace.
3. Measure:
 - Brake disc deflection
Out of specification → Correct the brake disc deflection or replace the brake disc.

	Brake disc deflection limit 0.10 mm (0.0039 in)
---	---

- a. Place the vehicle on a suitable stand so that the front wheel is elevated.
- b. Before measuring the front brake disc deflection, turn the handlebar to the left or right to ensure that the front wheel is stationary.
- c. Remove the brake caliper.
- d. Hold the dial gauge at a right angle against the brake disc surface.

- e. Measure the deflection 1.5 mm (0.06 in) below the edge of the brake disc.

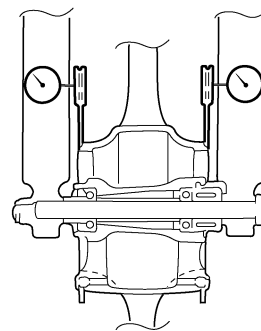

4. Measure:
 - Brake disc thickness
Measure the brake disc thickness at a few different locations.
Out of specification → Replace.

	Brake disc thickness limit 4.5 mm (0.18 in)
---	---

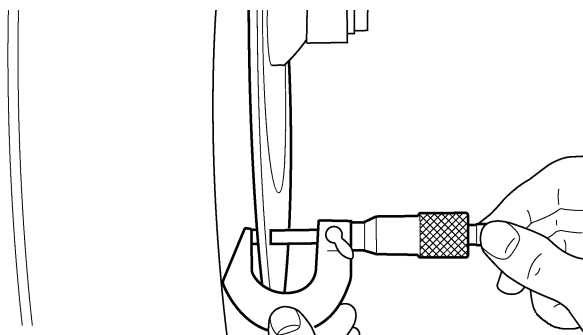

5. Adjust:
 - Brake disc deflection
- a. Remove the brake disc.
 - b. Rotate the brake disc by one bolt hole.
 - c. Install the brake disc.



	Front brake disc bolt 23 Nm (2.3 m·kg, 17ft·lb) LOCTITE®
---	---

- NOTE:**
- Apply locking agent (LOCTITE®) to the threads of the brake disc bolts.
 - Tighten the brake disc bolts in stages and in a crisscross pattern.

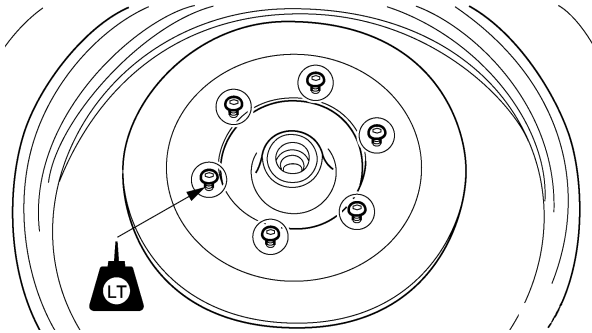

- d. Measure the brake disc deflection.
- e. If out of specification, repeat the adjustment steps until the brake disc deflection is within specification.
- f. If the brake disc deflection cannot be brought within specification, replace the brake disc.



6. Install:
 - Front wheel
 Refer to "FRONT WHEEL" on page 4-18.

EAS22270

REPLACING THE FRONT BRAKE PADS

The following procedure applies to both brake calipers.

NOTE:

When replacing the brake pads, it is not necessary to disconnect the brake hose or disassemble the brake caliper.

1. Measure:
 - Brake pad wear limit "a"
 Out of specification → Replace the brake pads as a set.



Brake pad lining thickness (inner)

5.5 mm (0.22 in)

Limit

0.5 mm (0.02 in)

Brake pad lining thickness (outer)

5.5 mm (0.22 in)

Limit

0.5 mm (0.02 in)

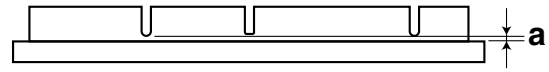

2. Install:
 - Brake pad shims (onto the brake pads)
 - Brake pads
 - Brake pad spring

NOTE:

Always install new brake pads, brake pad shims, and a brake pad spring as a set.



- a. Connect a clear plastic hose "1" tightly to the bleed screw "2". Put the other end of the hose into an open container.
- b. Loosen the bleed screw and push the brake caliper pistons into the brake caliper with your finger.

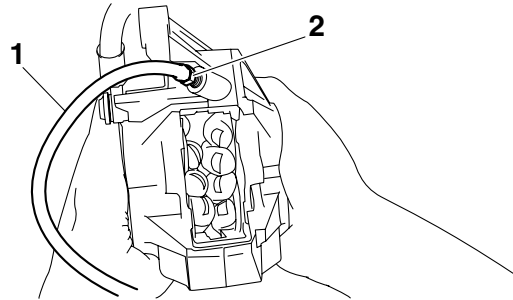

- c. Tighten the bleed screw.



Bleed screw (front brake caliper)
6 Nm (0.6 m·kg, 4.3ft·lb)

- d. Install a new brake pad shim onto each new brake pad.
- e. Install new brake pads and a new brake pad spring.

NOTE:

The arrow mark "a" on the brake pad spring must point in the direction of disc rotation.

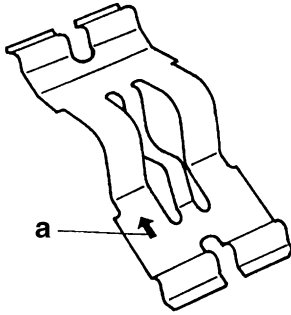

3. Install:

- Brake pad pin
- Brake pad clips
- Front brake caliper



Front brake caliper bolt
40 Nm (4.0 m·kg, 29 ft·lb)

4. Check:

- Brake fluid level
Below the minimum level mark “a” → Add the recommended brake fluid to the proper level. Refer to “CHECKING THE BRAKE FLUID LEVEL” on page 3-21.

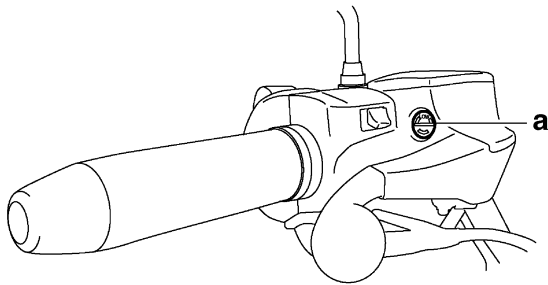

5. Check:

- Brake lever operation
Soft or spongy feeling → Bleed the brake system. Refer to “BLEEDING THE HYDRAULIC BRAKE SYSTEM” on page 3-24.

EAS22300

REMOVING THE FRONT BRAKE CALIPERS

The following procedure applies to both of the brake calipers.

NOTE:

Before removing the brake caliper, drain the brake fluid from the entire brake system.

1. Remove:

- Brake hose holder “1”
- Front brake hose union bolt “2”
- Copper washers “3”

- Front brake hose “4”

NOTE:

Put the end of the brake hose into a container and pump out the brake fluid carefully.

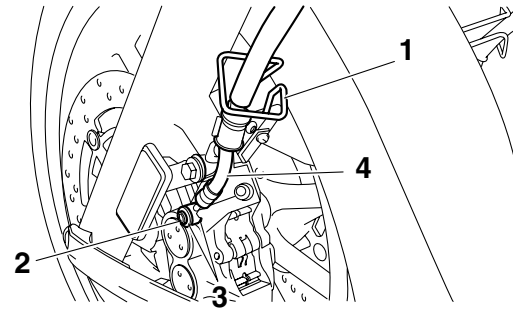

EAS22350

DISASSEMBLING THE FRONT BRAKE CALIPERS

The following procedure applies to both of the brake calipers.

1. Remove:

- Brake caliper pistons “1”
- Brake caliper piston seals “2”
- Brake caliper piston dust seals “3”

EWA1D77007

WARNING

Do not loosen the bolts “4”.

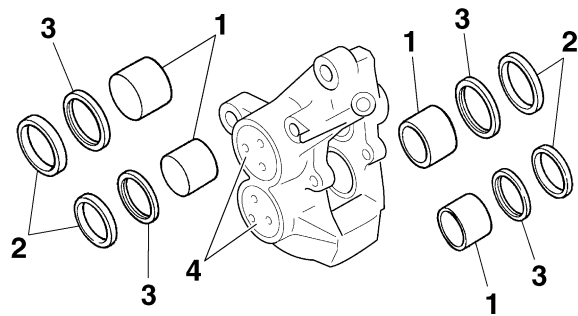

- a. Blow compressed air into the brake hose joint opening “a” to force out the pistons from the brake caliper.

EWA13560

WARNING

- Cover the brake caliper pistons with a rag. Be careful not to get injured when the pistons are expelled from the brake caliper.
- Never try to pry out the brake caliper pistons.

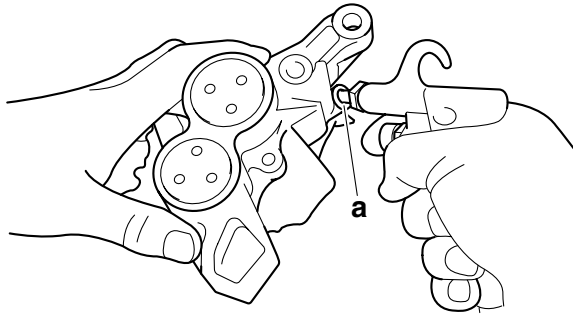

b. Remove the brake caliper piston seals and dust seals.



EAS22390

CHECKING THE FRONT BRAKE CALIPERS

Recommended brake component replacement schedule	
Brake pads	If necessary
Piston seals	Every two years
Dust seals	Every two years
Brake hoses	Every four years
Brake fluid	Every two years and whenever the brake is disassembled

1. Check:

- Brake caliper pistons “1”
Rust/scratches/wear → Replace the brake caliper pistons.
- Brake caliper cylinders “2”
Scratches/wear → Replace the brake caliper assembly.
- Brake caliper body “3”
Cracks/damage → Replace the brake caliper assembly.
- Brake fluid delivery passages (brake caliper body)
Obstruction → Blow out with compressed air.

EWA1D77003



Whenever a brake caliper is disassembled, replace the piston seals and dust seals.

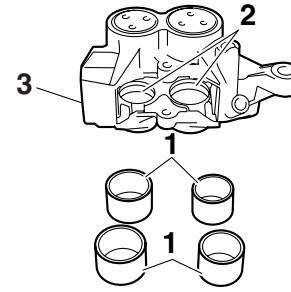

EAS22410

ASSEMBLING THE FRONT BRAKE CALIPERS

EWA1D77004



- Before installation, all internal brake components should be cleaned and lubricated with clean or new brake fluid.
- Never use solvents on internal brake components as they will cause the piston seals and dust seals to swell and distort.
- Whenever a brake caliper is disassembled, replace the brake caliper piston seals and dust seals.



**Recommended fluid
DOT 4**

EAS22440

INSTALLING THE FRONT BRAKE CALIPERS

The following procedure applies to both of the brake calipers.

1. Install:
 - Front brake caliper “1” (temporarily)
 - Copper washers **New**
 - Front brake hose “2”
 - Front brake hose union bolt “3”



**Front brake hose union bolt
32 Nm (3.2 m·kg, 23 ft·lb)**

EWA1D77008



Proper brake hose routing is essential to insure safe vehicle operation. Refer to “CABLE ROUTING (for XV19S(C)/ XV19M(C)/ XV19CTS(C)/ XV19CTM(C))” on page 2-51 and “CABLE ROUTING (for XV19CS(C)/ XV19C(C))” on page 2-67.

ECA14170

CAUTION: _____

When installing the brake hose onto the brake caliper "1", make sure the brake pipe "a" touches the projection "b" on the brake caliper.

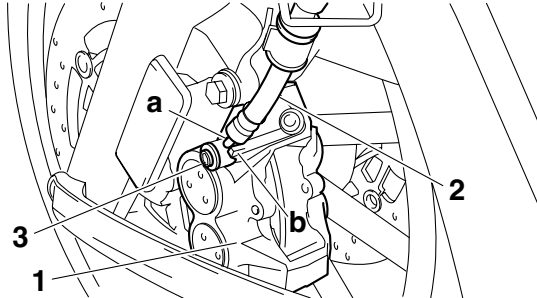

2. Remove:
 - Front brake caliper
3. Install:
 - Brake pads
 - Brake pad spring
 - Brake pad pin
 - Brake pad clips
 - Front brake caliper
 - Brake hose guide



Brake caliper bolt
 40 Nm (4.0 m·kg, 29 ft·lb)
Brake hose holder bolt
 10 Nm (1.0 m·kg, 7.2 ft·lb)
LOCTITE®

Refer to "REPLACING THE FRONT BRAKE PADS" on page 4-41.

4. Fill:
 - Brake master cylinder reservoir (with the specified amount of the recommended brake fluid)



Recommended fluid
DOT 4

EWA13090

WARNING _____

- Use only the designated brake fluid. Other brake fluids may cause the rubber seals to deteriorate, causing leakage and poor brake performance.
- Refill with the same type of brake fluid that is already in the system. Mixing brake fluids may result in a harmful chemical reaction, leading to poor brake performance.

- When refilling, be careful that water does not enter the brake fluid reservoir. Water will significantly lower the boiling point of the brake fluid and could cause vapor lock.

ECA13540

CAUTION: _____

Brake fluid may damage painted surfaces and plastic parts. Therefore, always clean up any spilt brake fluid immediately.

5. Bleed:
 - Brake system
 Refer to "BLEEDING THE HYDRAULIC BRAKE SYSTEM" on page 3-24.
6. Check:
 - Brake fluid level
 Below the minimum level mark "a" → Add the recommended brake fluid to the proper level. Refer to "CHECKING THE BRAKE FLUID LEVEL" on page 3-21.

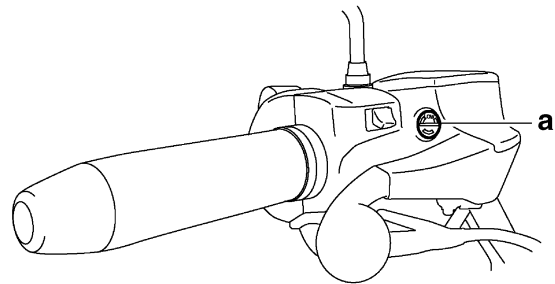

7. Check:
 - Brake lever operation
 Soft or spongy feeling → Bleed the brake system.
 Refer to "BLEEDING THE HYDRAULIC BRAKE SYSTEM" on page 3-24.

EAS22490

REMOVING THE FRONT BRAKE MASTER CYLINDER

NOTE: _____

Before removing the front brake master cylinder, drain the brake fluid from the entire brake system.

1. Remove:
 - Front brake hose union bolt "1"
 - Copper washers "2"
 - Front brake hose "3"

NOTE: _____

To collect any remaining brake fluid, place a container under the master cylinder and the end of the brake hose.

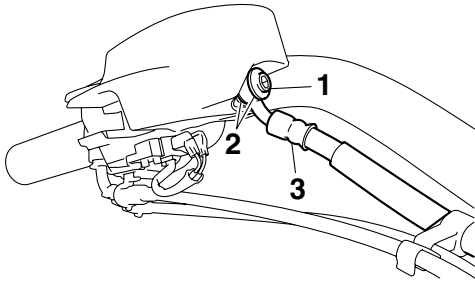

EAS22500

CHECKING THE FRONT BRAKE MASTER CYLINDER

1. Check:

- Brake master cylinder “1”
Damage/scratches/wear → Replace.
- Brake fluid delivery passages (brake master cylinder body)
Obstruction → Blow out with compressed air.

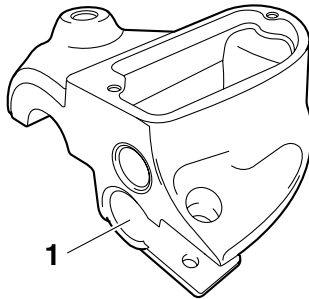

2. Check:

- Brake master cylinder kit
Damage/scratches/wear → Replace.

3. Check:

- Brake master cylinder reservoir
Cracks/damage → Replace.
- Brake master cylinder reservoir diaphragm
Damage/wear → Replace.

4. Check:

- Brake hose
Cracks/damage/wear → Replace.

EAS22520

ASSEMBLING THE FRONT BRAKE MASTER CYLINDER

EWA13520

⚠ WARNING

- Before installation, all internal brake components should be cleaned and lubricated with clean or new brake fluid.
- Never use solvents on internal brake components.



Recommended fluid
DOT 4

EAS22530

INSTALLING THE FRONT BRAKE MASTER CYLINDER

1. Install:

- Front brake master cylinder “1”
- Front brake master cylinder holder “2”



Front brake master cylinder holder bolt
10 Nm (1.0 m·kg, 7.2 ft·lb)

NOTE:

- Align the end of the brake master cylinder holder with the punch mark “a” on the handlebar.
- First, tighten the rear bolt, then the front bolt.

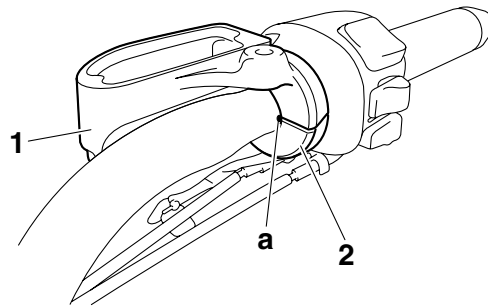

2. Install:

- Copper washers **New**
- Front brake hose “1”
- Front brake hose union bolt “2”



Front brake hose union bolt
30 Nm (3.0 m·kg, 22 ft·lb)

EWA1D77008

⚠ WARNING

Proper brake hose routing is essential to insure safe vehicle operation. Refer to “CABLE ROUTING (for XV19S(C)/ XV19M(C)/ XV19CTS(C)/ XV19CTM(C))” on page 2-51 and “CABLE ROUTING (for XV19CS(C)/ XV19C(C))” on page 2-67.

NOTE:

- Install the brake hose at a right angle to the front brake master cylinder as shown in the illustration.
- While holding the brake hose, tighten the union bolt.

- Turn the handlebar to the left and right to make sure the brake hose does not touch other parts (e.g., wire harness, cables, leads). Correct if necessary.

A

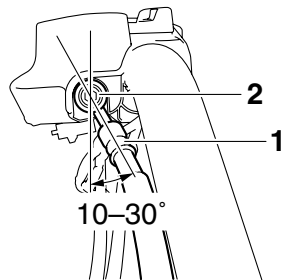

B

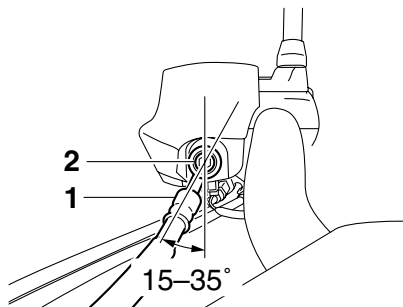

- A. For XV19S(C)/ XV19M(C)/ XV19CTS(C)/ XV19CTM(C)
 B. For XV19CS(C)/ XV19C(C)

3. Fill:
- Brake master cylinder reservoir (with the specified amount of the recommended brake fluid)



EWA13540

WARNING

- Use only the designated brake fluid. Other brake fluids may cause the rubber seals to deteriorate, causing leakage and poor brake performance.
- Refill with the same type of brake fluid that is already in the system. Mixing brake fluids may result in a harmful chemical reaction, leading to poor brake performance.
- When refilling, be careful that water does not enter the brake master cylinder reservoir. Water will significantly lower the boiling point of the brake fluid and could cause vapor lock.

ECA13540

CAUTION:

Brake fluid may damage painted surfaces and plastic parts. Therefore, always clean up any spill brake fluid immediately.

4. Bleed:
- Brake system
Refer to “BLEEDING THE HYDRAULIC BRAKE SYSTEM” on page 3-24.
5. Check:
- Brake fluid level
Below the minimum level mark “a” → Add the recommended brake fluid to the proper level. Refer to “CHECKING THE BRAKE FLUID LEVEL” on page 3-21.

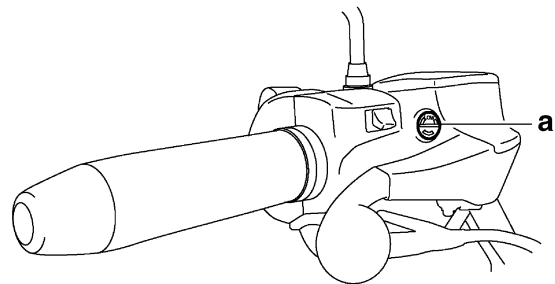

6. Check:
- Brake lever operation
Soft or spongy feeling → Bleed the brake system. Refer to “BLEEDING THE HYDRAULIC BRAKE SYSTEM” on page 3-24.

EAS22550

REAR BRAKE

Removing the rear brake pads

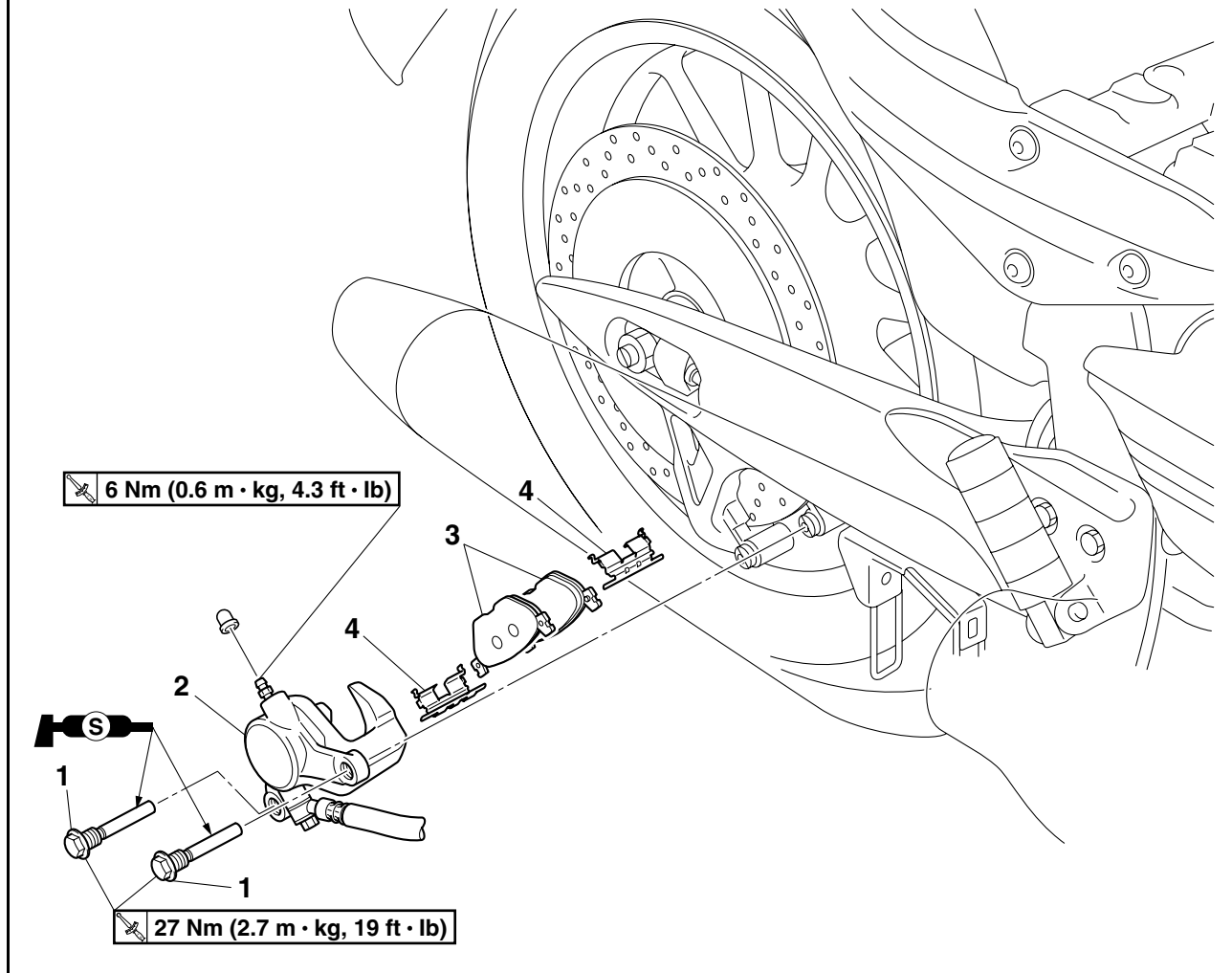

Order	Job/Parts to remove	Q'ty	Remarks
1	Rear brake caliper bolt	2	
2	Rear brake caliper	1	
3	Rear brake pad	2	
4	Brake pad spring	2	
			For installation, reverse the removal procedure.

Removing the rear brake master cylinder

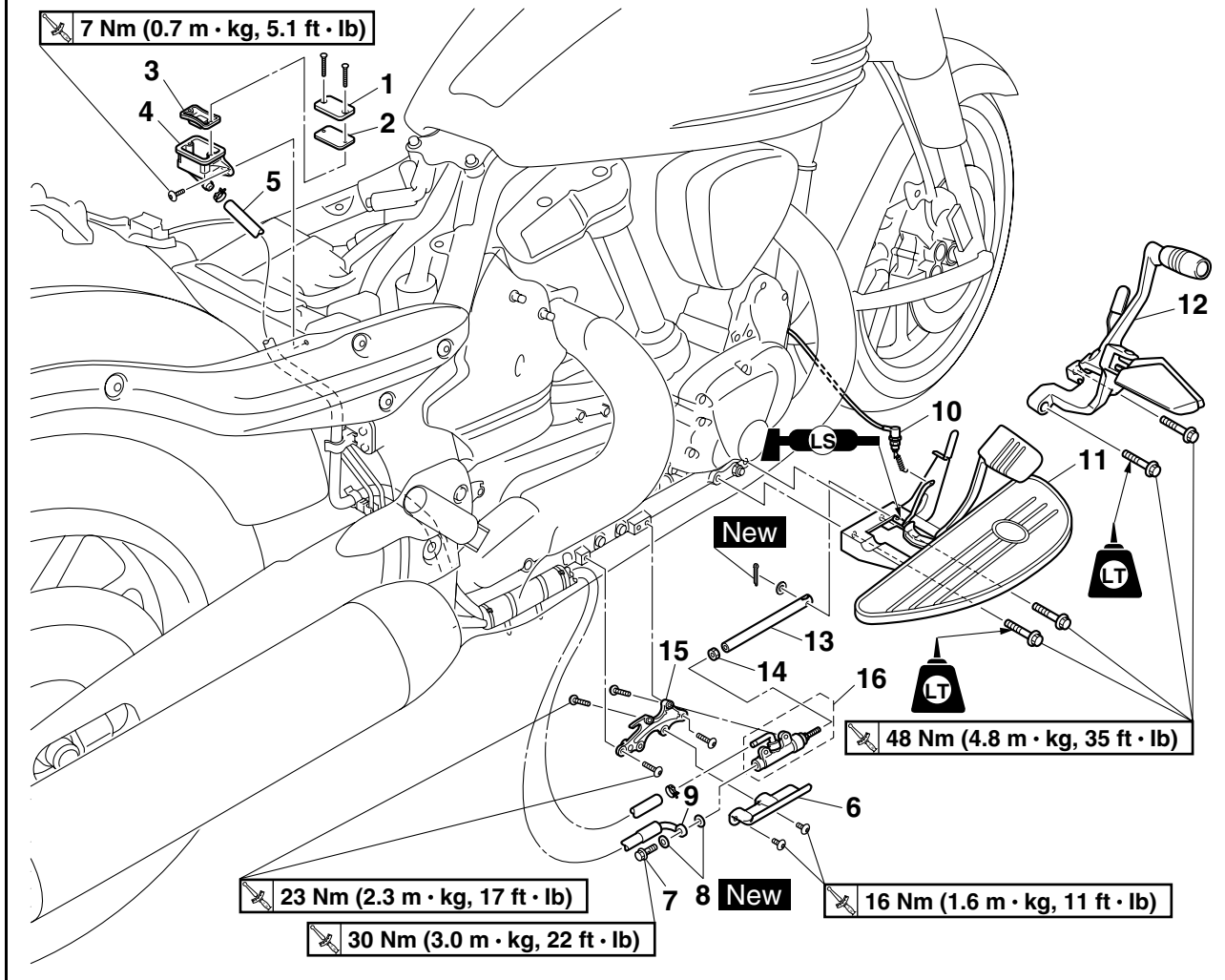

Order	Job/Parts to remove	Q'ty	Remarks
	Brake fluid		Drain. Refer to "BLEEDING THE HYDRAULIC BRAKE SYSTEM" on page 3-24.
1	Brake fluid reservoir cap	1	
2	Brake fluid reservoir diaphragm holder	1	
3	Brake fluid reservoir diaphragm	1	
4	Brake fluid reservoir	1	
5	Brake fluid reservoir hose	1	
6	Rear brake master cylinder cover	1	
7	Rear brake hose union bolt	1	
8	Copper washer	2	
9	Rear brake hose	1	
10	Rear brake light switch	1	
11	Right rider footrest assembly	1	For XV19S(C)/ XV19M(C)/ XV19CTS(C)/ XV19CTM(C)
12	Right rider footrest assembly	1	For XV19CS(C)/ XV19C(C)
13	Brake rod	1	
14	Locknut	1	
15	Brake master cylinder bracket	1	

Removing the rear brake master cylinder

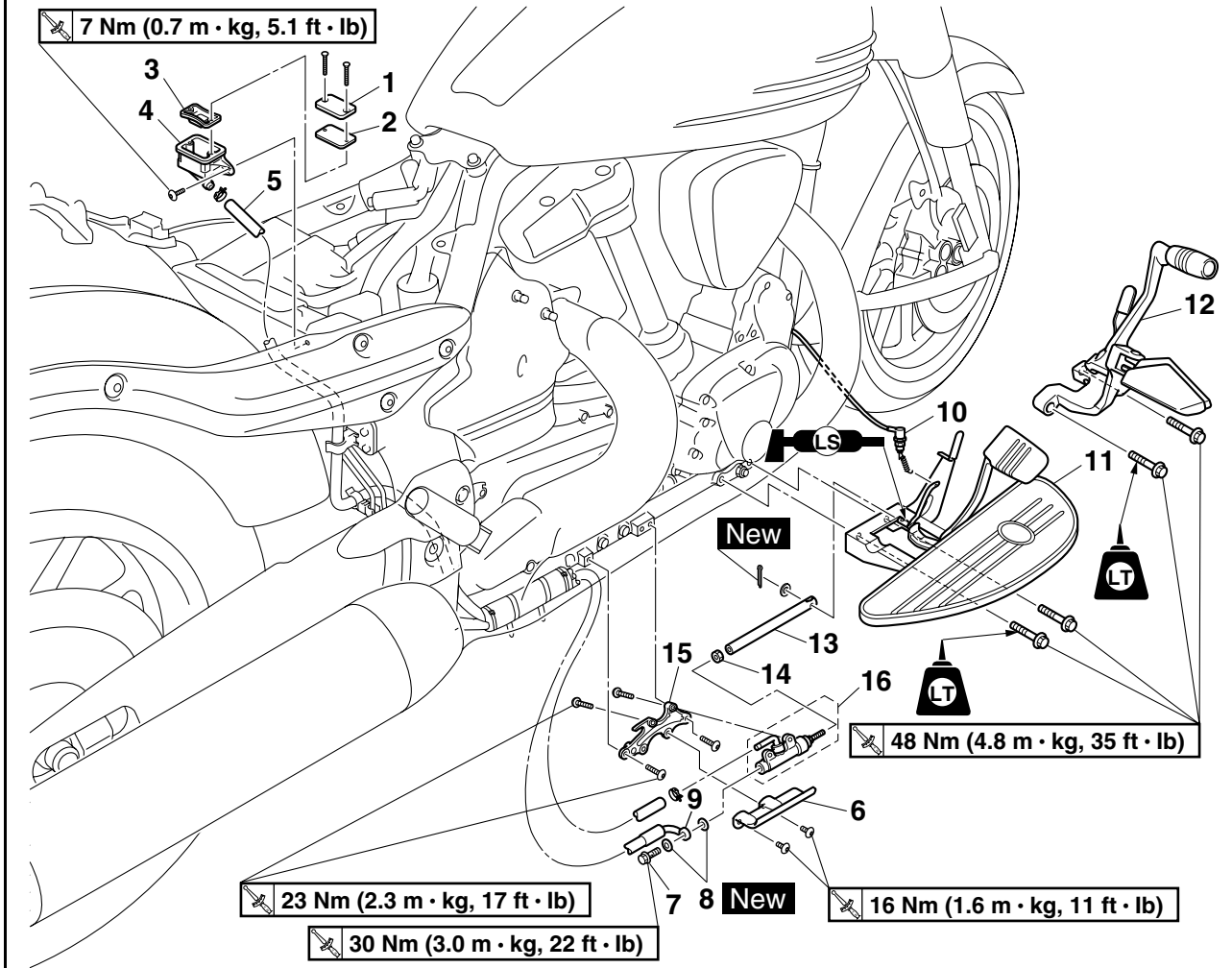

Order	Job/Parts to remove	Q'ty	Remarks
16	Brake master cylinder	1	
			For installation, reverse the removal procedure.

Disassembling the rear brake master cylinder

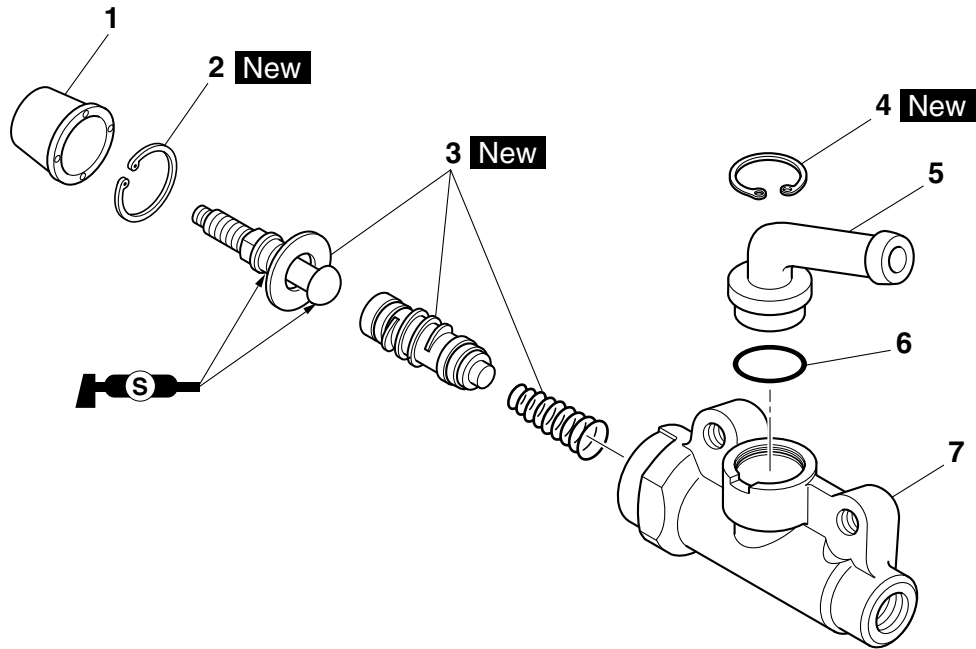

Order	Job/Parts to remove	Q'ty	Remarks
1	Dust boot	1	
2	Circlip	1	
3	Brake master cylinder kit	1	
4	Circlip	1	
5	Brake hose joint	1	
6	O-ring	1	
7	Brake master cylinder body	1	
			For assembly, reverse the disassembly procedure.

Removing the rear brake caliper

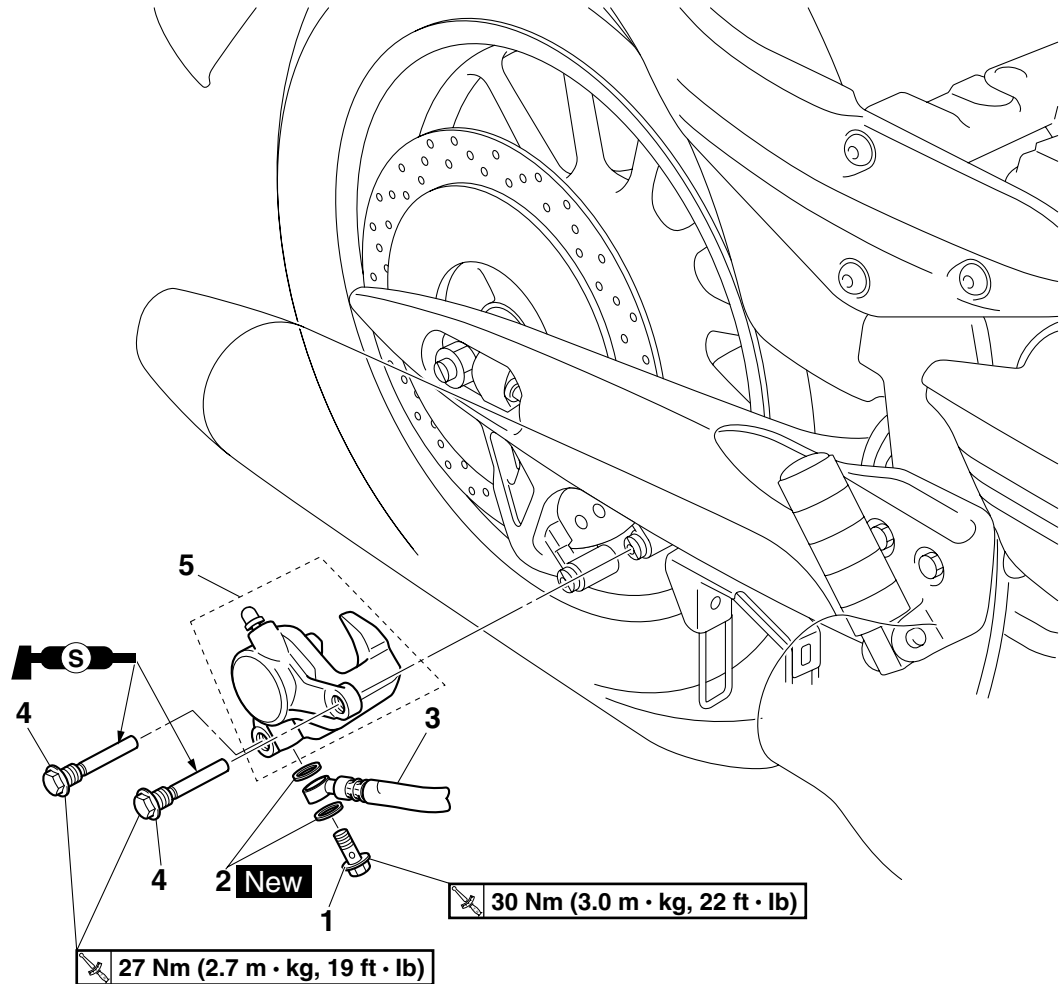

Order	Job/Parts to remove	Q'ty	Remarks
	Brake fluid		Drain. Refer to "BLEEDING THE HYDRAULIC BRAKE SYSTEM" on page 3-24.
1	Rear brake hose union bolt	1	
2	Copper washer	2	
3	Rear brake hose	1	
4	Rear brake caliper bolt	2	
5	Rear brake caliper	1	
			For installation, reverse the removal procedure.

Disassembling the rear brake caliper

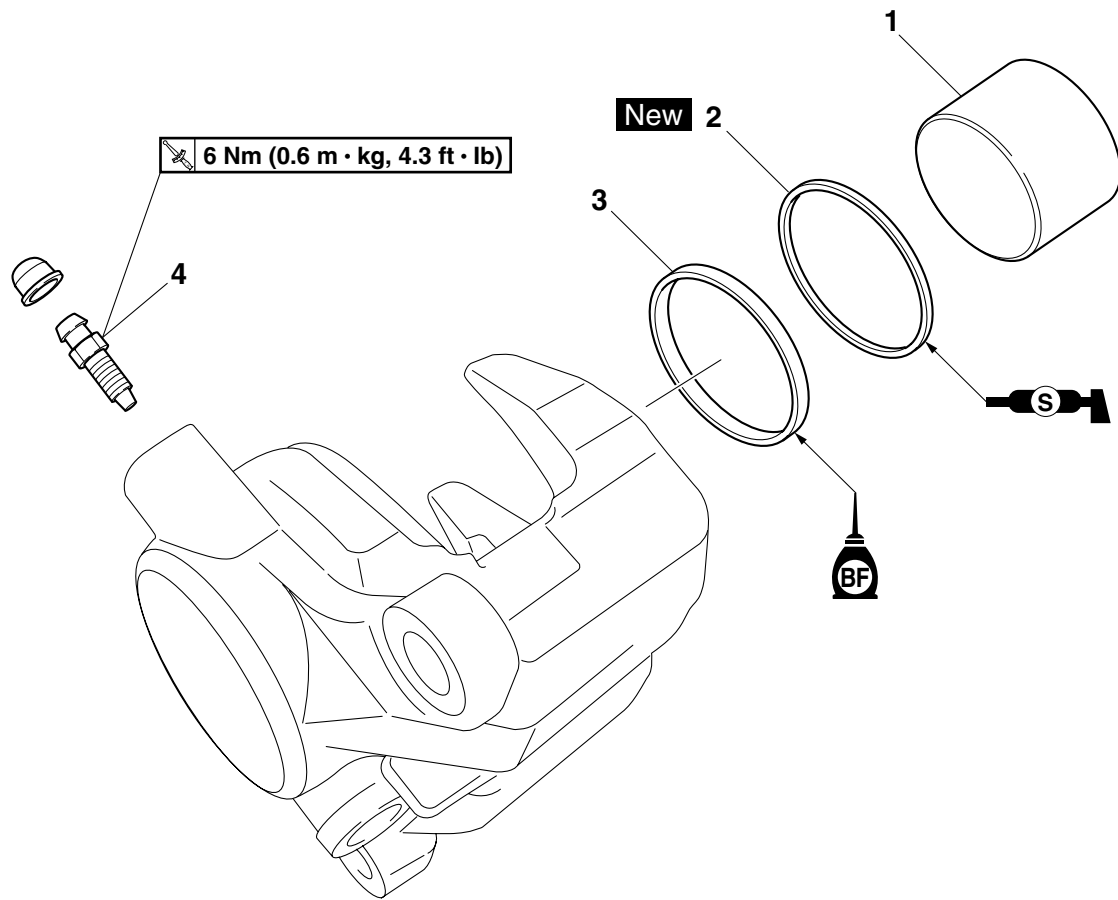

Order	Job/Parts to remove	Q'ty	Remarks
1	Brake caliper piston	1	
2	Brake caliper piston dust seal	1	
3	Brake caliper piston seal	1	
4	Bleed screw	1	
			For assembly, reverse the disassembly procedure.

EAS22560

INTRODUCTION

EWA14100



WARNING

Disc brake components rarely require disassembly. Therefore, always follow these preventive measures:

- Never disassemble brake components unless absolutely necessary.
- If any connection on the hydraulic brake system is disconnected, the entire brake system must be disassembled, drained, cleaned, properly filled, and bled after reassembly.
- Never use solvents on internal brake components.
- Use only clean or new brake fluid for cleaning brake components.
- Brake fluid may damage painted surfaces and plastic parts. Therefore, always clean up any spilt brake fluid immediately.
- Avoid brake fluid coming into contact with the eyes as it can cause serious injury.
- **FIRST AID FOR BRAKE FLUID ENTERING THE EYES:**
- Flush with water for 15 minutes and get immediate medical attention.

EAS22570

CHECKING THE REAR BRAKE DISC

1. Remove:
 - Rear wheel
Refer to "REAR WHEEL" on page 4-27.
2. Check:
 - Brake disc
Damage/galling → Replace.
3. Measure:
 - Brake disc deflection
Out of specification → Correct the brake disc deflection or replace the brake disc.
Refer to "CHECKING THE FRONT BRAKE DISCS" on page 4-40.



Brake disc deflection limit
0.15 mm (0.0059 in)

4. Measure:
 - Brake disc thickness
Measure the brake disc thickness at a few different locations.
Out of specification → Replace.
Refer to "CHECKING THE FRONT BRAKE DISCS" on page 4-40.



Brake disc thickness limit
5.5 mm (0.22 in)

5. Adjust:
 - Brake disc deflection
Refer to "CHECKING THE FRONT BRAKE DISCS" on page 4-40.



Brake disc bolt
18 Nm (1.8 m·kg, 13 ft·lb)
LOCTITE®

6. Install:
 - Rear wheel
Refer to "REAR WHEEL" on page 4-27.

EAS22580

REPLACING THE REAR BRAKE PADS

NOTE:

When replacing the brake pads, it is not necessary to disconnect the brake hose or disassemble the brake caliper.

1. Measure:
 - Brake pad wear limit "a"
Out of specification → Replace the brake pads as a set.



Brake pad lining thickness (inner)
5.8 mm (0.23 in)
Limit
0.8 mm (0.03 in)
Brake pad lining thickness (outer)
5.8 mm (0.23 in)
Limit
0.8 mm (0.03 in)

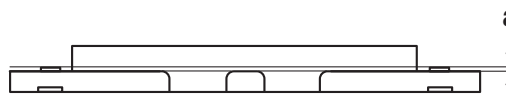

2. Install:
 - Brake pads
 - Brake pad springs

NOTE:

Always install new brake pads and brake pad springs as a set.

- a. Connect a clear plastic hose "1" tightly to the bleed screw "2". Put the other end of the hose into an open container.
- b. Loosen the bleed screw and push the brake caliper piston into the brake caliper with your finger.

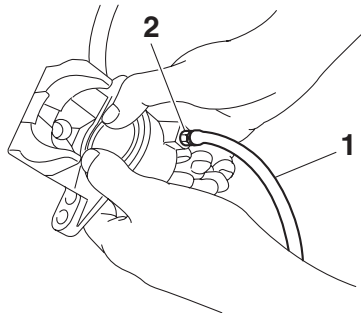

- c. Tighten the bleed screw.



Bleed screw (rear brake caliper)
6 Nm (0.6 m·kg, 4.3 ft·lb)

3. Install:

- Brake caliper



Rear brake caliper bolt
27 Nm (2.7 m·kg, 19 ft·lb)

4. Check:

- Brake fluid level
Below the minimum level mark "a" → Add the recommended brake fluid to the proper level. Refer to "CHECKING THE BRAKE FLUID LEVEL" on page 3-21.

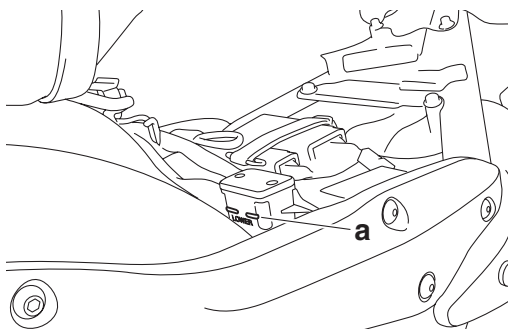

5. Check:

- Brake pedal operation
Soft or spongy feeling → Bleed the brake system.

Refer to "BLEEDING THE HYDRAULIC BRAKE SYSTEM" on page 3-24.

EAS22590

REMOVING THE REAR BRAKE CALIPER

NOTE:

Before disassembling the brake caliper, drain the brake fluid from the entire brake system.

1. Remove:

- Rear brake hose union bolt "1"
- Copper washers "2"
- Rear brake hose "3"

NOTE:

Put the end of the brake hose into a container and pump out the brake fluid carefully.

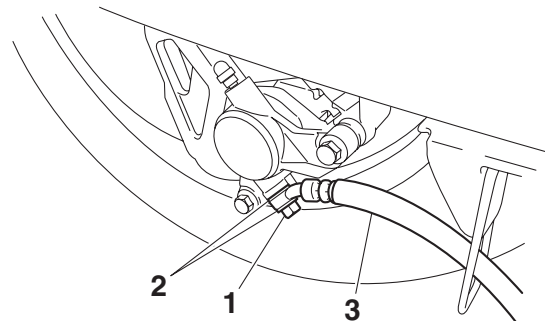

EAS22600

DISASSEMBLING THE REAR BRAKE CALIPER

1. Remove:

- Brake caliper piston
- Brake caliper piston seal
- Brake caliper piston dust seal

- a. Blow compressed air into the brake hose joint opening "a" to force out the piston from the brake caliper.

EWA13550

WARNING

- Cover the brake caliper piston with a rag. Be careful not to get injured when the piston is expelled from the brake caliper.
- Never try to pry out the brake caliper piston.

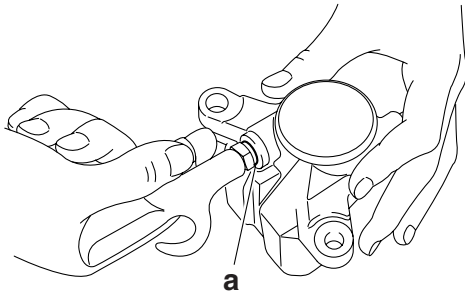

- b. Remove the brake caliper piston seal and dust seal.



EAS22640

CHECKING THE REAR BRAKE CALIPER

Recommended brake component replacement schedule	
Brake pads	If necessary
Piston seal	Every two years
Dust seal	Every two years
Brake hoses	Every four years
Brake fluid	Every two years and whenever the brake is disassembled

1. Check:
- Brake caliper piston “1”
Rust/scratches/wear → Replace the brake caliper piston.
 - Brake caliper cylinder “2”
Scratches/wear → Replace the brake caliper assembly.
 - Brake caliper body “3”
Cracks/damage → Replace the brake caliper assembly.
 - Brake fluid delivery passages (brake caliper body)
Obstruction → Blow out with compressed air.

EWA1D77005



Whenever a brake caliper is disassembled, replace the brake caliper piston seal and dust seal.

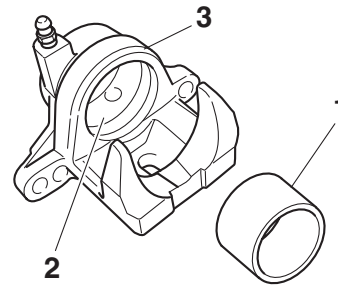

EAS22650

ASSEMBLING THE REAR BRAKE CALIPER

EWA1D77006



- Before installation, all internal brake components should be cleaned and lubricated with clean or new brake fluid.
- Never use solvents on internal brake components as they will cause the piston seal and dust seal to swell and distort.
- Whenever a brake caliper is disassembled, replace the brake caliper piston seal and dust seal.



**Recommended fluid
DOT 4**

EAS22670

INSTALLING THE REAR BRAKE CALIPER

1. Install:
- Rear brake caliper “1” (temporarily)
 - Copper washers **New**
 - Rear brake hose “2”
 - Rear brake hose union bolt “3”



**Rear brake hose union bolt
30 Nm (3.0 m·kg, 22 ft·lb)**

EWA1D77008



Proper brake hose routing is essential to insure safe vehicle operation. Refer to “CABLE ROUTING (for XV19S(C)/ XV19M(C)/ XV19CTS(C)/ XV19CTM(C))” on page 2-51 and “CABLE ROUTING (for XV19CS(C)/ XV19C(C))” on page 2-67.

ECA14170

CAUTION:

When installing the brake hose onto the brake caliper “1”, make sure the brake pipe “a” touches the projection “b” on the brake caliper.

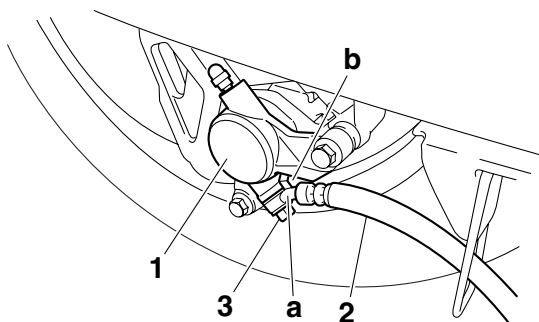

2. Remove:

- Rear brake caliper

3. Install:

- Brake pads
- Brake pad springs
- Rear brake caliper bolts
- Rear brake caliper

Refer to “REPLACING THE REAR BRAKE PADS” on page 4-53.



Rear brake caliper bolt
27 Nm (2.7 m·kg, 19 ft·lb)

4. Fill:

- Brake fluid reservoir
(with the specified amount of the recommended brake fluid)



Recommended fluid
DOT 4

EWA13090

WARNING

- Use only the designated brake fluid. Other brake fluids may cause the rubber seals to deteriorate, causing leakage and poor brake performance.
- Refill with the same type of brake fluid that is already in the system. Mixing brake fluids may result in a harmful chemical reaction, leading to poor brake performance.
- When refilling, be careful that water does not enter the brake fluid reservoir. Water will significantly lower the boiling point of the brake fluid and could cause vapor lock.

ECA13540

CAUTION:

Brake fluid may damage painted surfaces and plastic parts. Therefore, always clean up any spilt brake fluid immediately.

5. Bleed:

- Brake system
Refer to “BLEEDING THE HYDRAULIC BRAKE SYSTEM” on page 3-24.

6. Check:

- Brake fluid level
Below the minimum level mark “a” → Add the recommended brake fluid to the proper level. Refer to “CHECKING THE BRAKE FLUID LEVEL” on page 3-21.

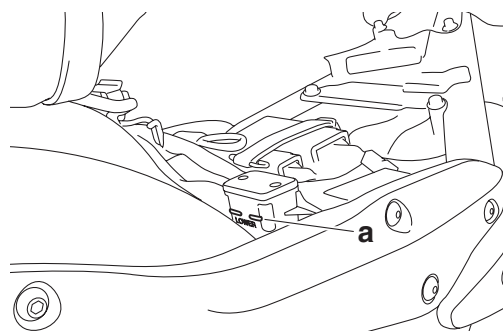

7. Check:

- Brake pedal operation
Soft or spongy feeling → Bleed the brake system. Refer to “BLEEDING THE HYDRAULIC BRAKE SYSTEM” on page 3-24.

EAS22700

REMOVING THE REAR BRAKE MASTER CYLINDER

NOTE:

Before removing the rear brake master cylinder, drain the brake fluid from the entire brake system.

1. Remove:

- Rear brake hose union bolt “1”
- Copper washers “2”
- Rear brake hose “3”

NOTE:

To collect any remaining brake fluid, place a container under the master cylinder and the end of the brake hose.

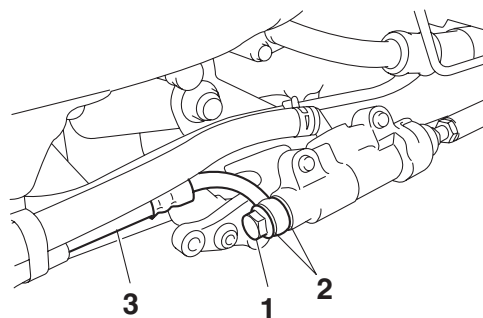

EAS22720

CHECKING THE REAR BRAKE MASTER CYLINDER

1. Check:
 - Brake master cylinder
Damage/scratches/wear → Replace.
 - Brake fluid delivery passages (brake master cylinder body)
Obstruction → Blow out with compressed air.
2. Check:
 - Brake master cylinder kit
Damage/scratches/wear → Replace.
3. Check:
 - Brake fluid reservoir
Cracks/damage → Replace.
 - Brake fluid reservoir diaphragm
Cracks/damage → Replace.
4. Check:
 - Brake hoses
Cracks/damage/wear → Replace.

EAS22730

ASSEMBLING THE REAR BRAKE MASTER CYLINDER

EWA13520

WARNING

- Before installation, all internal brake components should be cleaned and lubricated with clean or new brake fluid.
- Never use solvents on internal brake components.

	Recommended fluid DOT 4
---	------------------------------------

EAS22740

INSTALLING THE REAR BRAKE MASTER CYLINDER

1. Install:
 - Copper washers “1” **New**
 - Rear brake hose “2”
 - Rear brake hose union bolt “3”

	Rear brake hose union bolt 30 Nm (3.0 m·kg, 22 ft·lb)
---	--

EWA1D77008

WARNING

Proper brake hose routing is essential to insure safe vehicle operation. Refer to “CABLE ROUTING (for XV19S(C)/ XV19M(C)/ XV19CTS(C)/ XV19CTM(C))” on page 2-51 and “CABLE ROUTING (for XV19CS(C)/ XV19C(C))” on page 2-67.

EC1D71009

CAUTION:

When installing the brake hose onto the brake master cylinder, make sure the brake pipe touches the projection “a” on the brake caliper bracket as shown.

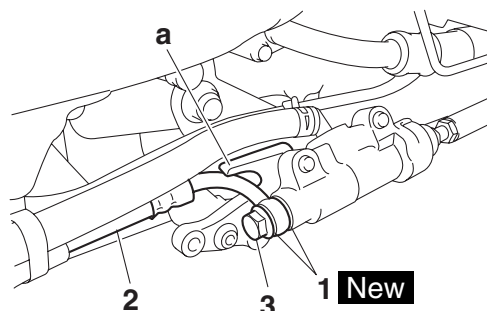

2. Fill:
 - Brake fluid reservoir
(with the specified amount of the recommended brake fluid)

	Recommended fluid DOT 4
---	------------------------------------

EWA13090

WARNING

- Use only the designated brake fluid. Other brake fluids may cause the rubber seals to deteriorate, causing leakage and poor brake performance.
- Refill with the same type of brake fluid that is already in the system. Mixing brake fluids may result in a harmful chemical reaction, leading to poor brake performance.
- When refilling, be careful that water does not enter the brake fluid reservoir. Water will significantly lower the boiling point of the brake fluid and could cause vapor lock.

ECA13540

CAUTION:

Brake fluid may damage painted surfaces and plastic parts. Therefore, always clean up any spilt brake fluid immediately.

3. Bleed:
 - Brake system
Refer to “BLEEDING THE HYDRAULIC BRAKE SYSTEM” on page 3-24.
4. Check:
 - Brake fluid level
Below the minimum level mark “a” → Add the recommended brake fluid to the proper level. Refer to “CHECKING THE BRAKE FLUID LEVEL” on page 3-21.

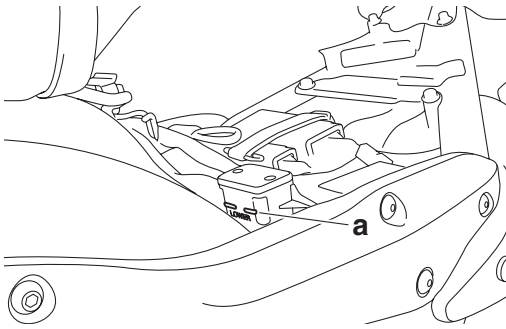

5. Check:
 - Brake pedal operation
Soft or spongy feeling → Bleed the brake system.
Refer to “BLEEDING THE HYDRAULIC BRAKE SYSTEM” on page 3-24.
6. Adjust:
 - Brake pedal position
Refer to “ADJUSTING THE REAR DISC BRAKE” on page 3-21.
7. Adjust:
 - Rear brake light operation timing
Refer to “ADJUSTING THE REAR BRAKE LIGHT SWITCH” on page 3-23.

EAS22840

HANDLEBAR

Removing the handlebar (for XV19S(C)/ XV19M(C)/ XV19CTS(C)/ XV19CTM(C))

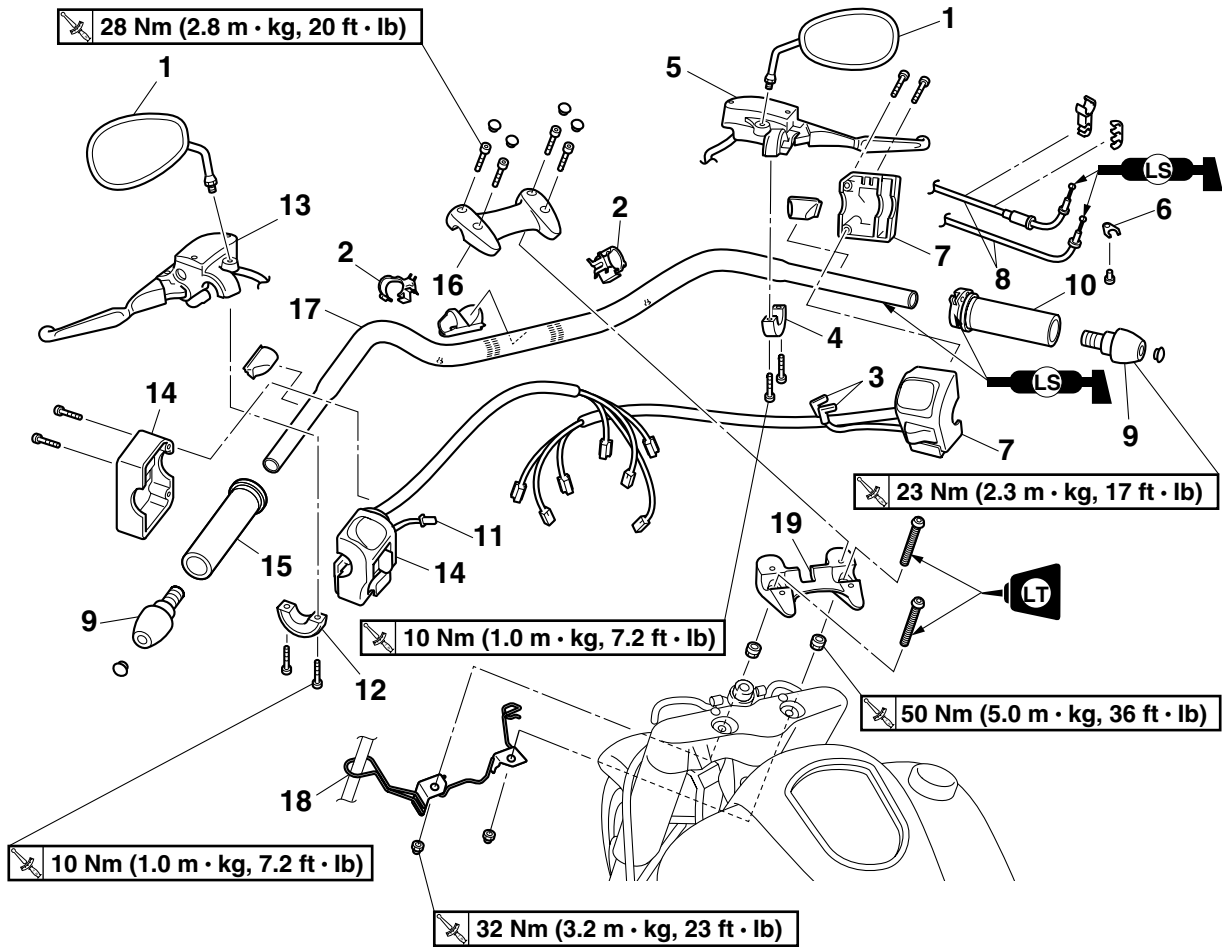

Order	Job/Parts to remove	Q'ty	Remarks
	Headlight body		Refer to "GENERAL CHASSIS" on page 4-1.
1	Rearview mirror	2	
2	Plastic clamp	2	
3	Front brake light switch connector	2	Disconnect.
4	Front brake master cylinder holder	1	
5	Front brake master cylinder assembly	1	
6	Throttle cable holder	1	
7	Right handlebar switch	1	
8	Throttle cable	2	
9	Grip end	2	
10	Throttle grip	1	
11	Clutch switch coupler	1	Disconnect.
12	Clutch master cylinder holder	1	
13	Clutch master cylinder assembly	1	
14	Left handlebar switch	1	

Removing the handlebar (for XV19S(C)/ XV19M(C)/ XV19CTS(C)/ XV19CTM(C))

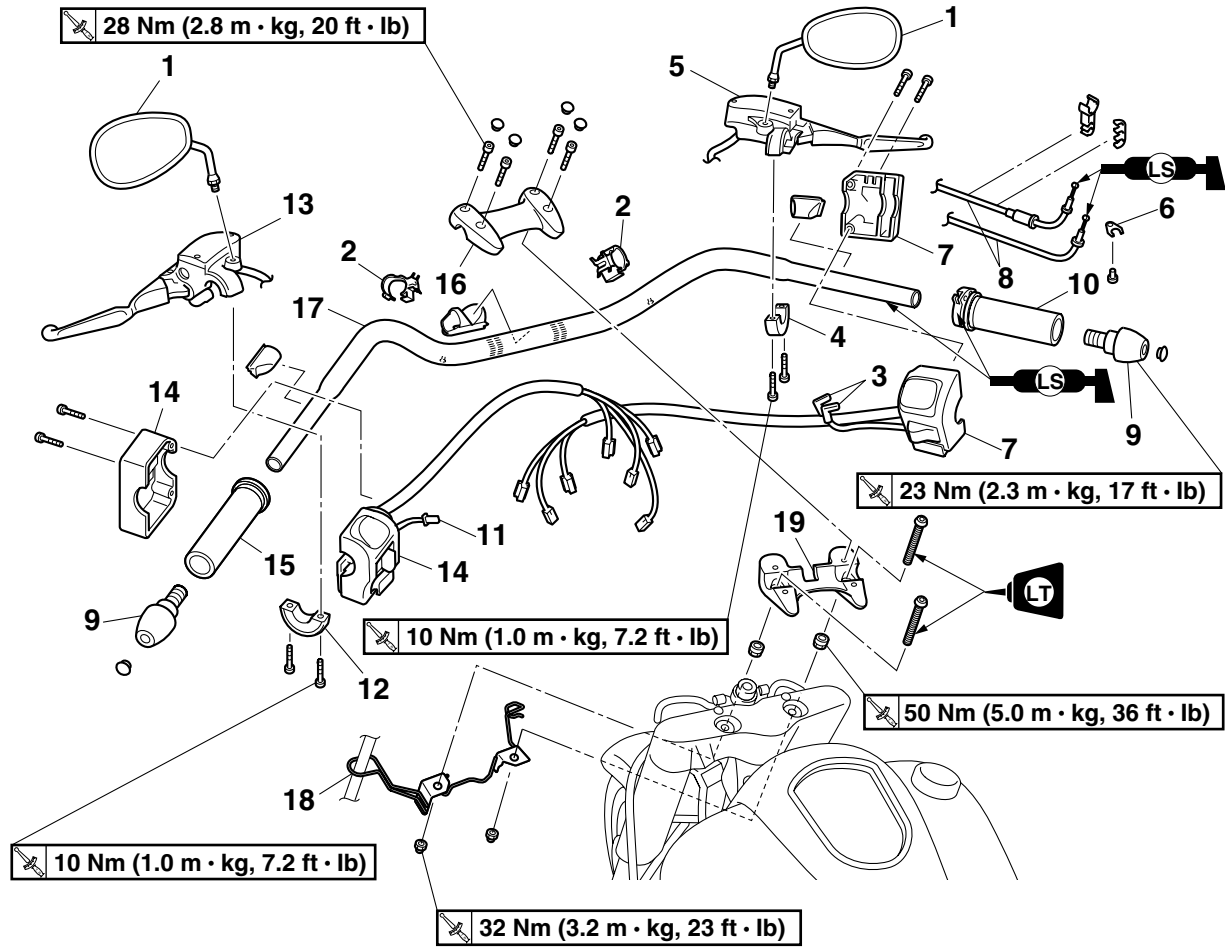

Order	Job/Parts to remove	Q'ty	Remarks
15	Handlebar grip	1	
16	Upper handlebar holder	1	
17	Handlebar	1	
18	Hose guide	1	
19	Lower handlebar holder	1	
			For installation, reverse the removal procedure.

Removing the handlebar (for XV19CS(C)/ XV19C(C))

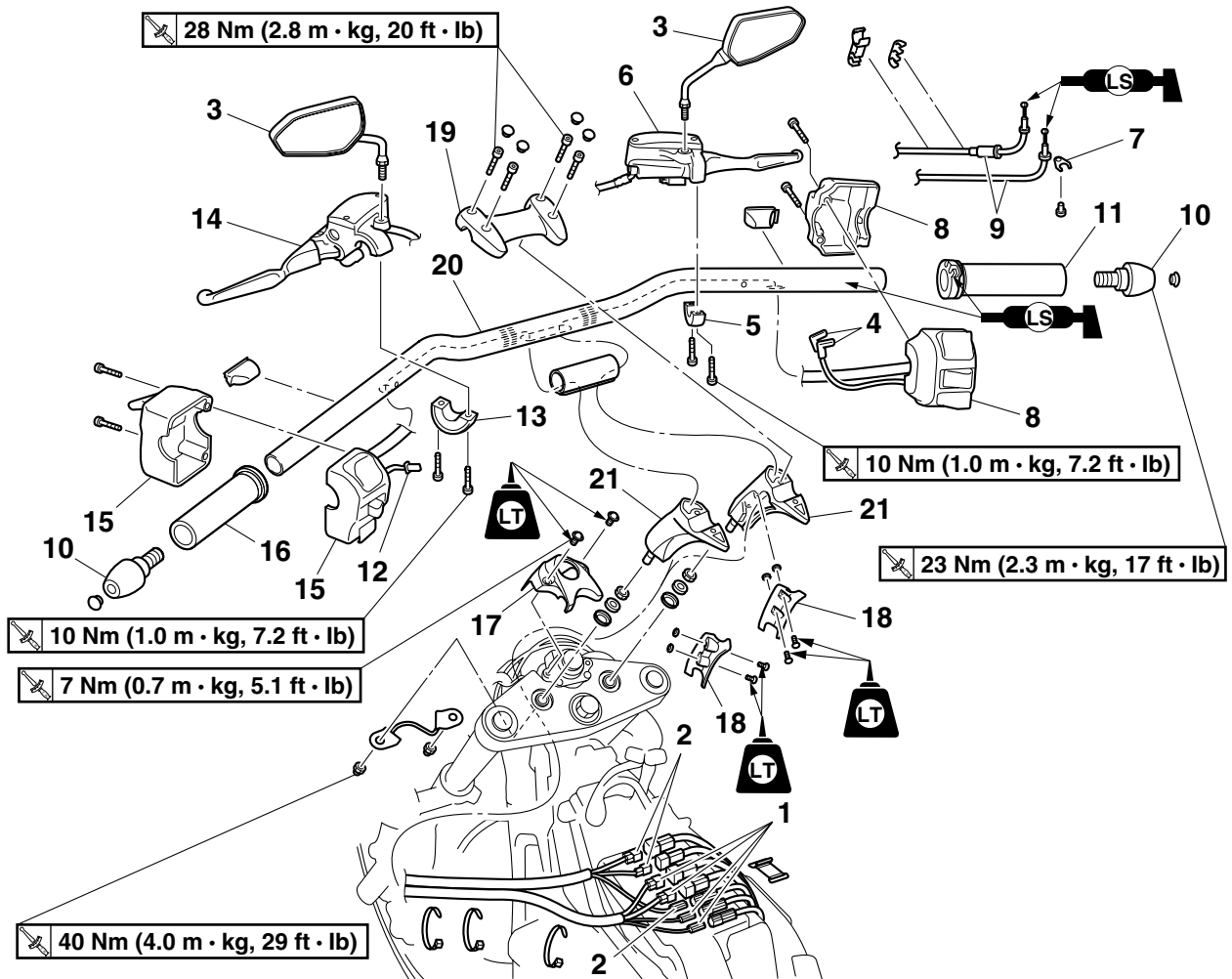

Order	Job/Parts to remove	Q'ty	Remarks
	Headlight bracket		Refer to "GENERAL CHASSIS" on page 4-1.
	Fuel tank		Refer to "FUEL TANK" on page 6-1.
1	Left handlebar switch coupler	4	Disconnect.
2	Right handlebar switch coupler	3	Disconnect.
3	Rearview mirror	2	
4	Front brake light switch connector	2	Disconnect.
5	Front brake master cylinder holder	1	
6	Front brake master cylinder assembly	1	
7	Throttle cable holder	1	
8	Right handlebar switch	1	
9	Throttle cable	2	
10	Grip end	2	
11	Throttle grip	1	
12	Clutch switch coupler	1	Disconnect.
13	Clutch master cylinder holder	1	
14	Clutch master cylinder assembly	1	
15	Left handlebar switch	1	

Removing the handlebar (for XV19CS(C)/ XV19C(C))

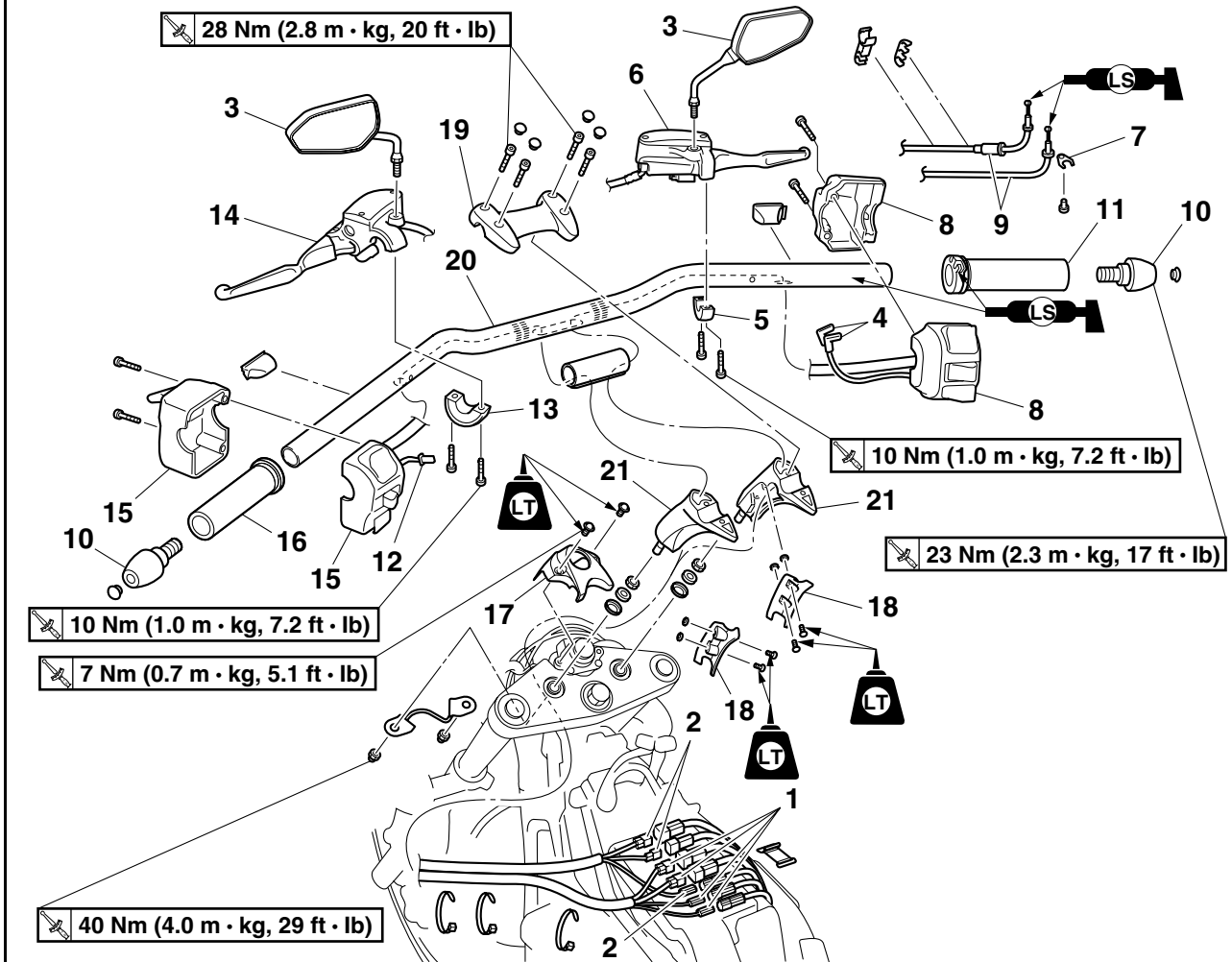

Order	Job/Parts to remove	Q'ty	Remarks
16	Handlebar grip	1	
17	Main switch cover	1	
18	Lead holder	2	
19	Upper handlebar holder	1	
20	Handlebar	1	
21	Lower handlebar holder	2	
			For installation, reverse the removal procedure.

EWA13700

WARNING

Do not touch the handlebar grip until the rubber adhesive has fully dried.



6. Install:

- Left handlebar switch “1”

NOTE:

Align the projection “a” on the left handlebar switch with the hole “b” in the handlebar.

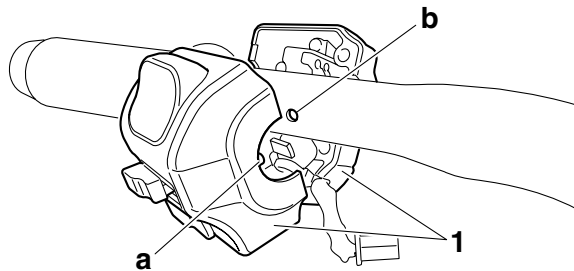

7. Install:

- Clutch master cylinder “1”
- Clutch master cylinder holder “2”



Clutch master cylinder holder bolt
10 Nm (1.0 m·kg, 7.2 ft·lb)

NOTE:

- Align the end of the clutch master cylinder holder with the punch mark “a” on the handlebar.
- First tighten the rear bolt, then the front bolt.

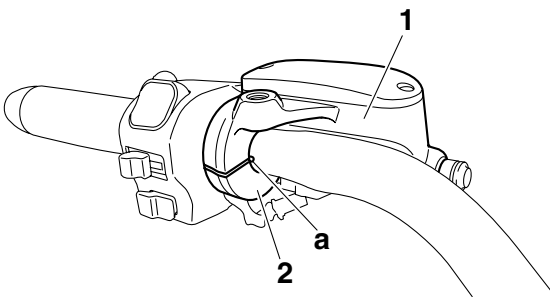

8. Install:

- Throttle grip
- Throttle cables
- Right handlebar switch “1”
- Grip end “2”

NOTE:

- Align the projection “a” on the right handlebar switch with the hole “b” in the handlebar.

- There should be 1–3 mm (0.04–0.12 in) of clearance “c” between the throttle grip and the grip end.

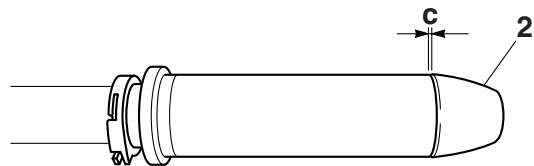
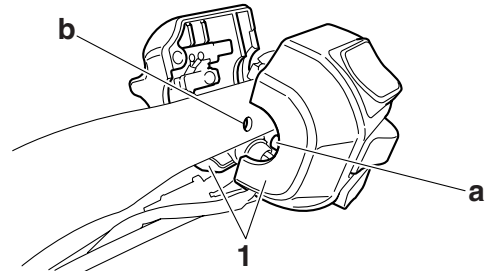

9. Install:

- Front brake master cylinder “1”
- Front brake master cylinder holder “2”



Front brake master cylinder holder bolt
10 Nm (1.0 m·kg, 7.2 ft·lb)

NOTE:

- Align the end of the front brake master cylinder holder with the punch mark “a” on the handlebar.
- First tighten the rear bolt, then the front bolt.

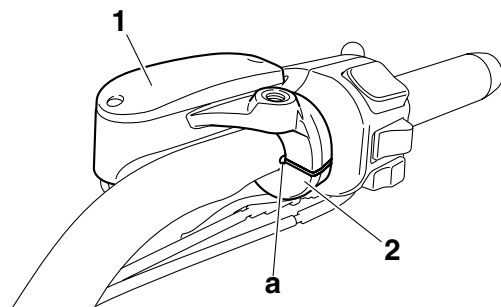

10. Adjust:

- Throttle cable free play
Refer to “ADJUSTING THE THROTTLE CABLE FREE PLAY” on page 3-8.



Throttle cable free play
4.0–6.0 mm (0.16–0.24 in)

EAS22950

FRONT FORK

Removing the front fork legs (for XV19S(C)/ XV19M(C)/ XV19CTS(C)/ XV19CTM(C))

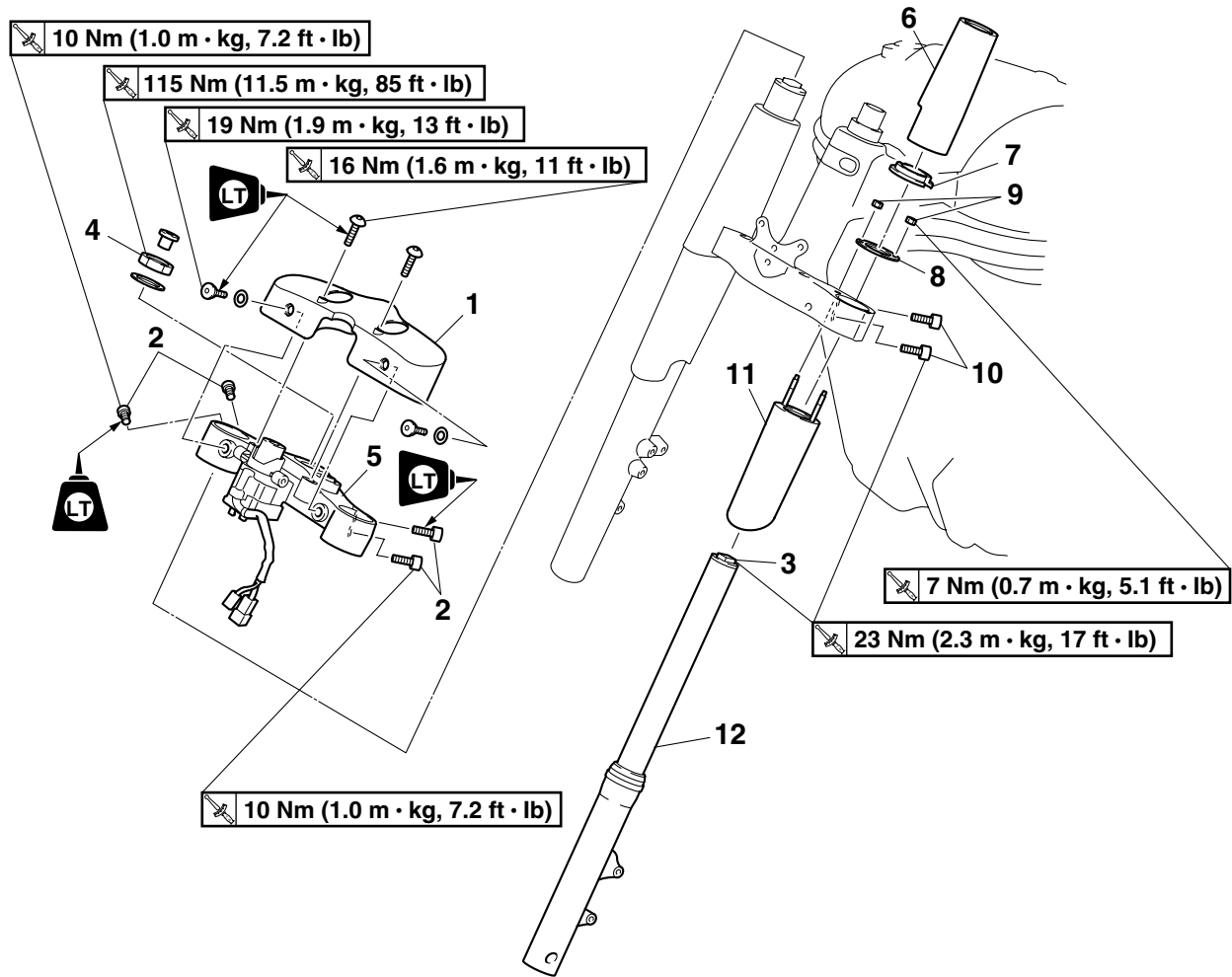

Order	Job/Parts to remove	Q'ty	Remarks
			The following procedure applies to both of the front fork legs.
	Windshield bracket (left and right)		For XV19CTS(C)/ XV19CTM(C)
	Lower handlebar holder		Refer to "HANDLEBAR" on page 4-59.
	Front wheel		Refer to "FRONT WHEEL" on page 4-18.
1	Upper bracket cover	1	
2	Upper bracket pinch bolt	4	Loosen.
3	Cap bolt	1	Loosen.
4	Steering stem nut	1	
5	Upper bracket	1	
6	Upper front fork cover	1	
7	Upper front fork cover spacer	1	
8	Upper front fork cover washer	1	
9	Lower front fork cover nut	2	
10	Lower bracket pinch bolt	2	Loosen.
11	Lower front fork cover	1	

FRONT FORK

Removing the front fork legs (for XV19S(C)/ XV19M(C)/ XV19CTS(C)/ XV19CTM(C))

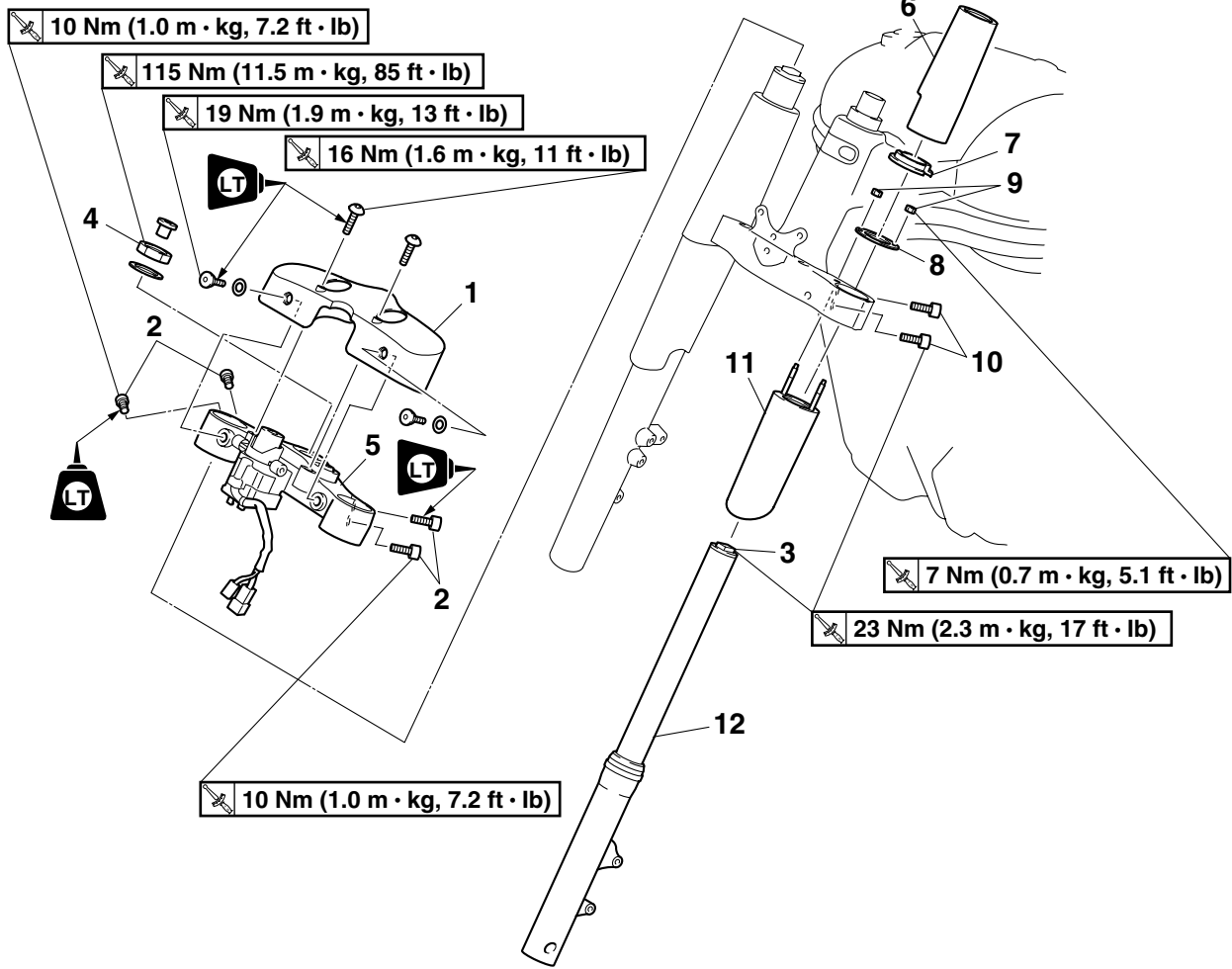

Order	Job/Parts to remove	Q'ty	Remarks
12	Front fork leg	1	
			For installation, reverse the removal procedure.

Removing the front fork legs (for XV19CS(C)/ XV19C(C))

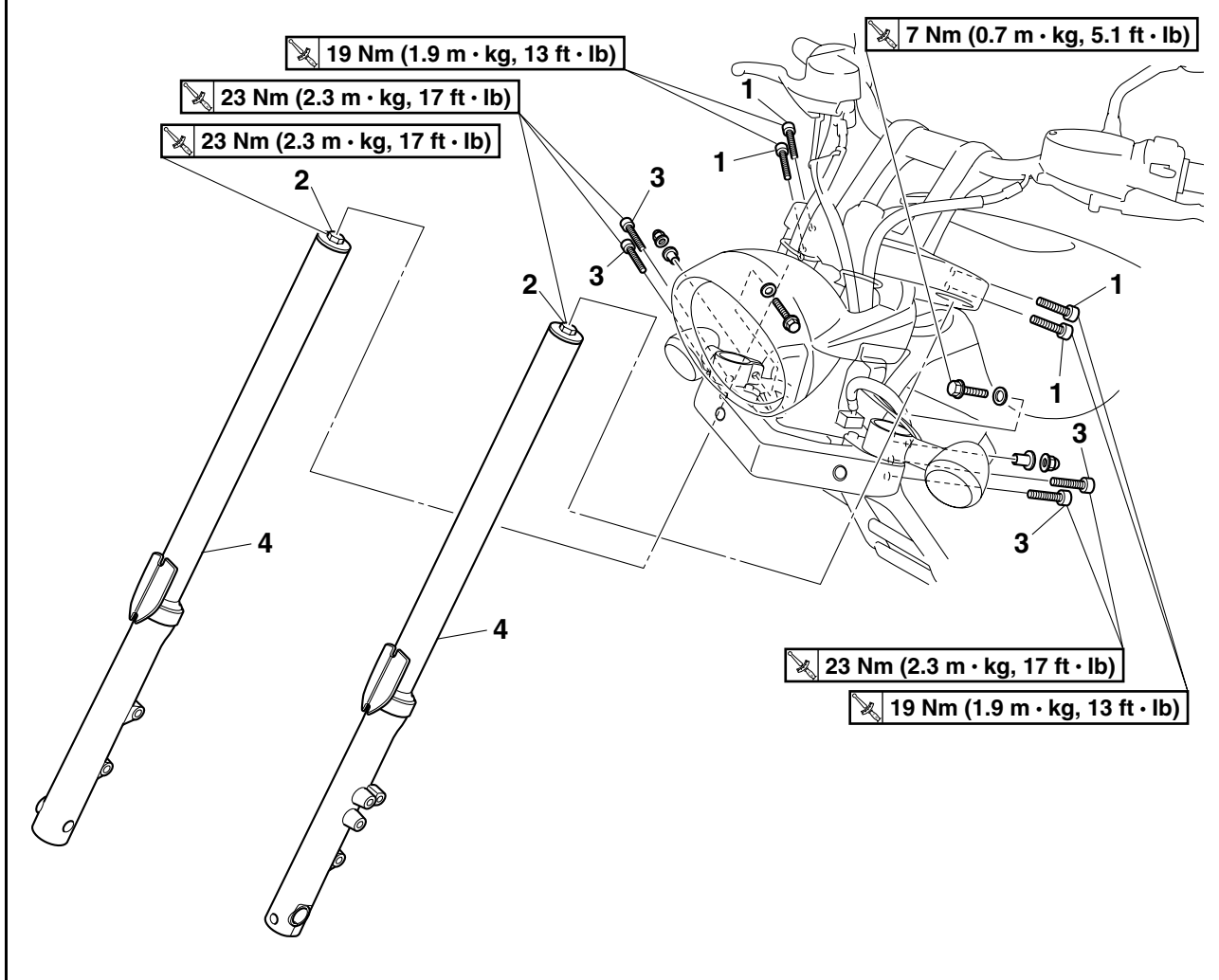

Order	Job/Parts to remove	Q'ty	Remarks
			The following procedure applies to both of the front fork legs.
	Front wheel		Refer to "FRONT WHEEL" on page 4-18.
1	Upper bracket pinch bolt	4	Loosen.
2	Cap bolt	2	Loosen.
3	Lower bracket pinch bolt	4	Loosen.
4	Front fork leg	2	
			For installation, reverse the removal procedure.

Disassembling the front fork legs

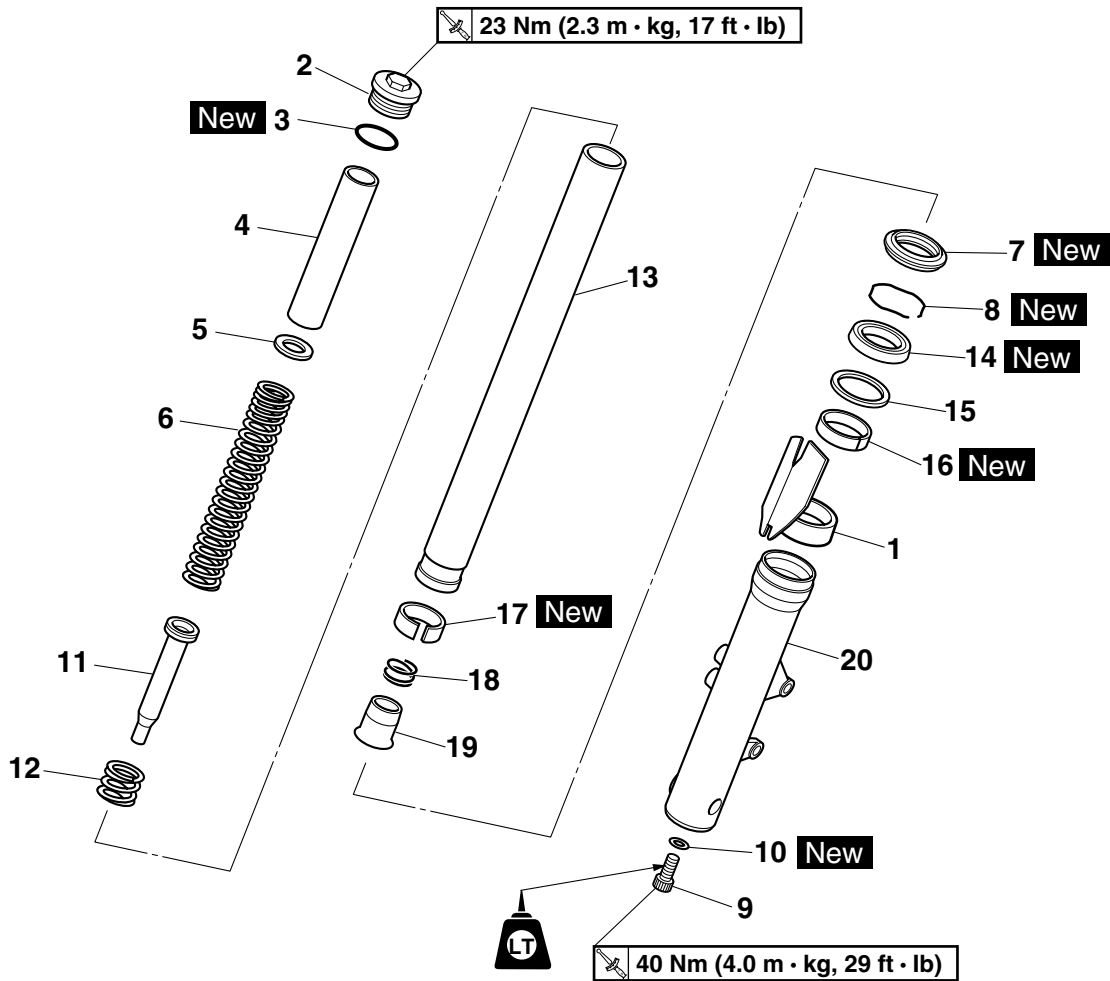

Order	Job/Parts to remove	Q'ty	Remarks
			The following procedure applies to both of the front fork legs.
1	Protector	1	For XV19CS(C)/ XV19C(C)
2	Cap bolt	1	
3	O-ring	1	
4	Spacer	1	
5	Spring seat	1	
6	Fork spring	1	
7	Dust seal	1	
8	Oil seal clip	1	
9	Damper rod bolt	1	
10	Copper washer	1	
11	Damper rod	1	
12	Rebound spring	1	
13	Inner tube	1	
14	Oil seal	1	
15	Washer	1	
16	Outer tube bushing	1	

Disassembling the front fork legs

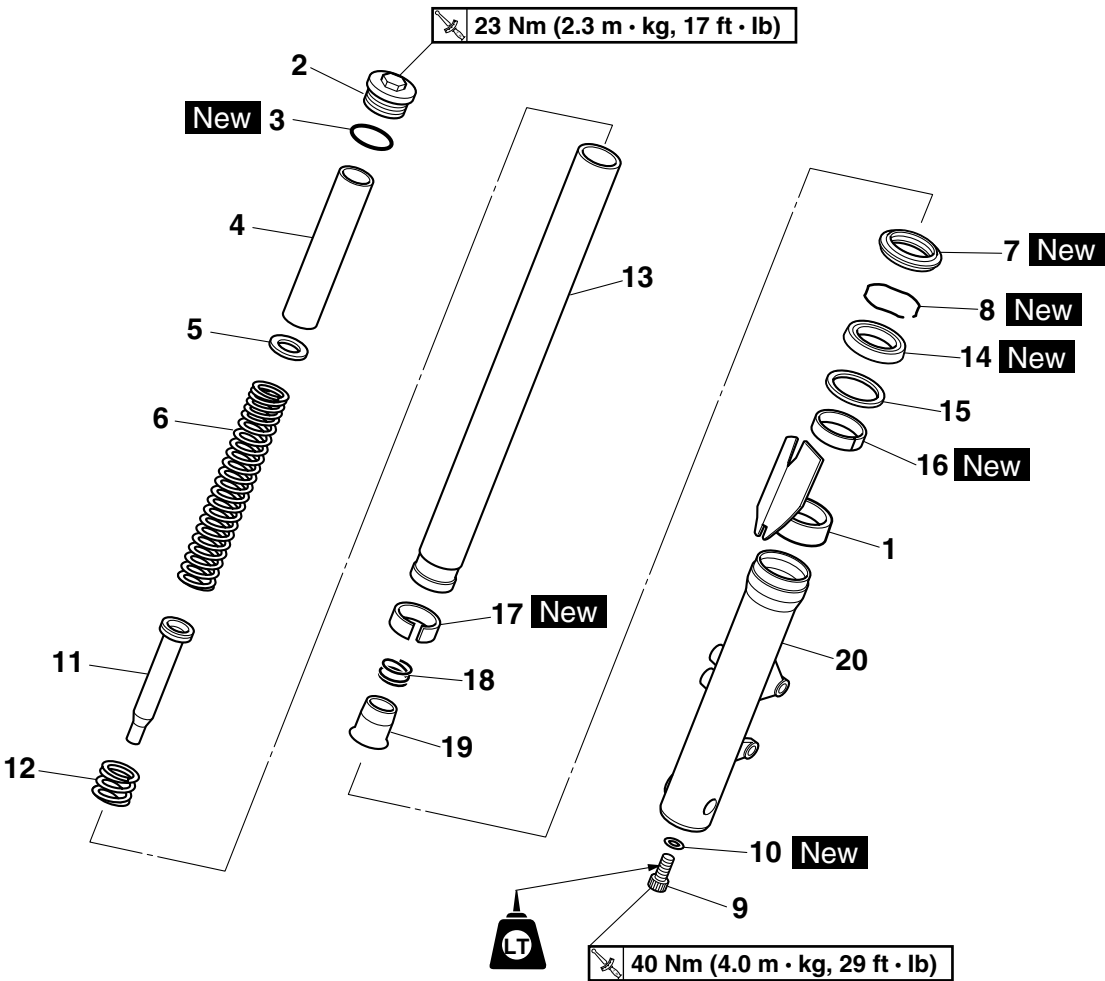

Order	Job/Parts to remove	Q'ty	Remarks
17	Inner tube bushing	1	
18	Spring	1	
19	Oil flow stopper	1	
20	Outer tube	1	
			For assembly, reverse the disassembly procedure.

EAS22960

REMOVING THE FRONT FORK LEGS

The following procedure applies to both of the front fork legs.

1. Stand the vehicle on a level surface.

EWA13120

WARNING

Securely support the vehicle so that there is no danger of it falling over.

NOTE:

Place the vehicle on a suitable stand so that the front wheel is elevated.

2. Loosen:
 - Lower bracket pinch bolts

EW1D71007

WARNING

Before loosening the lower bracket pinch bolts, support the front fork leg.

EAS22980

DISASSEMBLING THE FRONT FORK LEGS

The following procedure applies to both of the front fork legs.

1. Drain:
 - Fork oil

NOTE:

Stroke the outer tube several times while draining the fork oil.

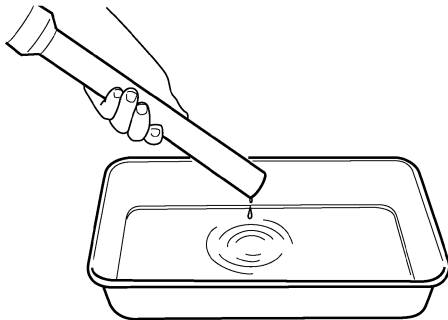

2. Remove:
 - Dust seal "1"
 - Oil seal clip "2"

(with a flathead screwdriver)

ECA14180

CAUTION:

Do not scratch the inner tube.

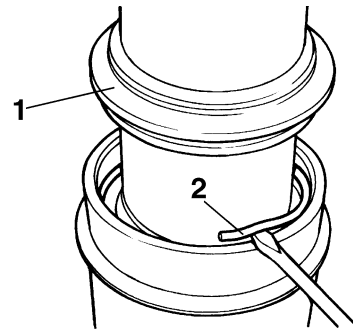

3. Remove:
 - Damper rod bolt "1"
 - Copper washer

NOTE:

While holding the damper rod with the damper rod holder "2" and T-handle "3", loosen the damper rod bolt.



Damper rod holder

90890-01460

T-handle

90890-01326

T-handle 3/8" drive 60 cm long

YM-01326

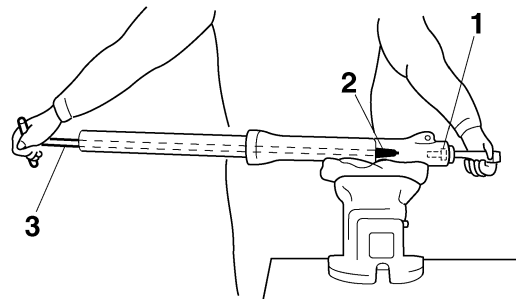

4. Remove:
 - Inner tube

- a. Hold the front fork leg horizontally.
- b. Securely clamp the brake caliper bracket in a vise with soft jaws.
- c. Separate the inner tube from the outer tube by pulling the inner tube forcefully but carefully.

ECA14190

CAUTION:

- Excessive force will damage the oil seal and bushing. A damaged oil seal or bushing must be replaced.
- Avoid bottoming the inner tube into the outer tube during the above procedure, as the oil flow stopper will be damaged.

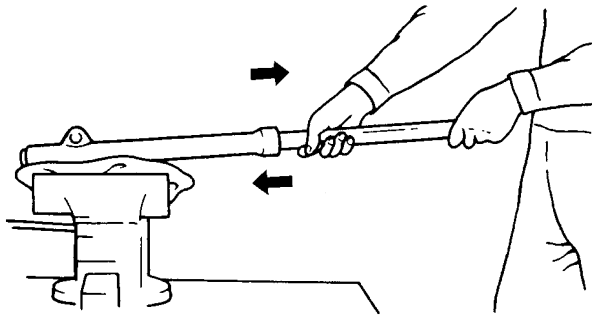

EAS23010

CHECKING THE FRONT FORK LEGS

The following procedure applies to both of the front fork legs.

1. Check:

- Inner tube
 - Outer tube
- Bends/damage/scratches → Replace.

EWA13650

WARNING

Do not attempt to straighten a bent inner tube as this may dangerously weaken it.

2. Measure:

- Spring free length "a"
- Out of specification → Replace.



Fork spring free length
XV19S(C)/ XV19M(C)/
XV19CTS(C)/ XV19CTM(C):
273.9 mm (10.78 in)
XV19CS(C)/ XV19C(C):
407.0 mm (16.02 in)
Limit
XV19S(C)/ XV19M(C)/
XV19CTS(C)/ XV19CTM(C):
268.4 mm (10.57 in)
XV19CS(C)/ XV19C(C):
398.9 mm (15.70 in)

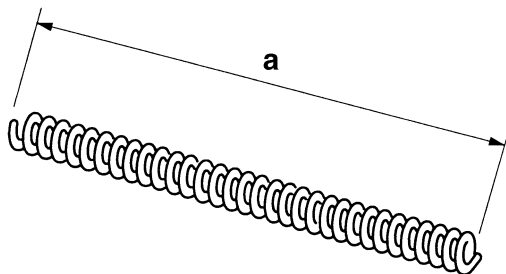

3. Check:

- Damper rod
- Damage/wear → Replace.

Obstruction → Blow out all of the oil passages with compressed air.

- Oil flow stopper
- Damage → Replace.

ECA14200

CAUTION:

- **The front fork leg has a built-in damper adjusting rod and a very sophisticated internal construction, which are particularly sensitive to foreign material.**
- **When disassembling and assembling the front fork leg, do not allow any foreign material to enter the front fork.**

4. Check:

- Cap bolt O-ring
- Damage/wear → Replace.

EAS23020

ASSEMBLING THE FRONT FORK LEGS

The following procedure applies to both of the front fork legs.

EWA13660

WARNING

- **Make sure the oil levels in both front fork legs are equal.**
- **Uneven oil levels can result in poor handling and a loss of stability.**

NOTE:

- When assembling the front fork leg, be sure to replace the following parts:
 - Inner tube bushing
 - Outer tube bushing
 - Oil seal
 - Dust seal
- Before assembling the front fork leg, make sure all of the components are clean.

1. Install:

- Inner tube bushing "1"
- Damper rod "2"
- Rebound spring
- Spring "3"
- Oil flow stopper "4"

EC1D71012

CAUTION:

Allow the damper rod to slide slowly down the inner tube "5" until it protrudes from the bottom of the inner tube. Be careful not to damage the inner tube.

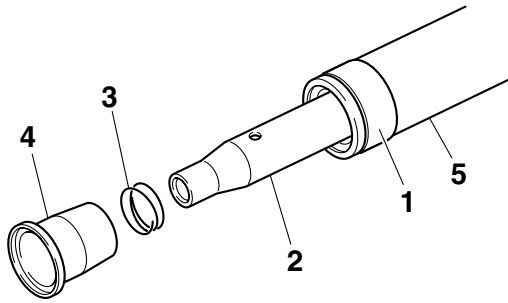

2. Lubricate:
- Inner tube's outer surface

	Recommended oil Yamaha fork oil 10WT
---	---

3. Install:
- Inner tube
(in the outer tube)
4. Install:
- Copper washer **New**
 - Damper rod bolt
5. Tighten:
- Damper rod bolt "1"

	Damper rod bolt 40 Nm (4.0 m·kg, 29 ft·lb) LOCTITE®
--	--

NOTE: _____
 While holding the damper rod assembly with the damper rod holder "2" and T-handle "3", tighten the damper rod bolt.

	Damper rod holder 90890-01460 T-handle 90890-01326 T-handle 3/8" drive 60 cm long YM-01326
---	---

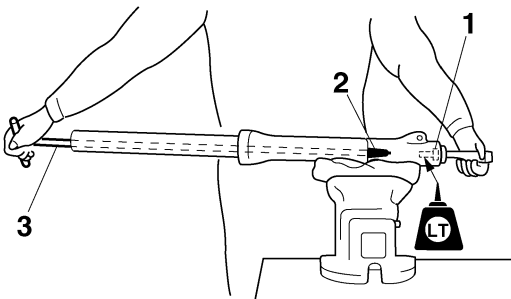

6. Install:
- Outer tube bushing "1"

- Washer
(with the fork seal driver "2")

	Fork seal driver 90890-01442 Adjustable fork seal driver (36–46 mm) YM-01442
---	---

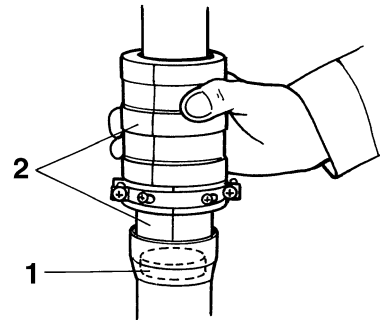

7. Install:
- Oil seal "1"
(with the fork seal driver "2")

ECA14220

CAUTION: _____
Make sure the numbered side of the oil seal faces up.

- NOTE:** _____
- Before installing the oil seal, lubricate its lips with lithium-soap-based grease.
 - Lubricate the outer surface of the inner tube with fork oil.
 - Before installing the oil seal, cover the top of the front fork leg with a plastic bag to protect the oil seal during installation.



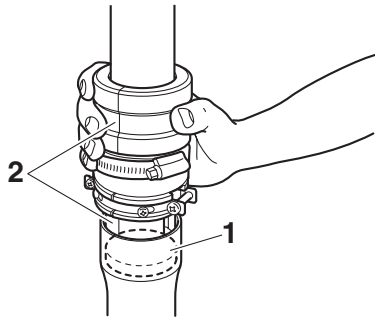



8. Install:
- Oil seal clip “1”

NOTE:

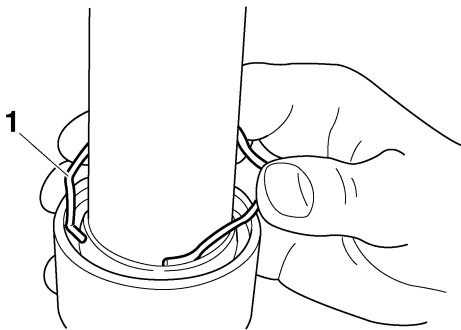
Adjust the oil seal clip so that it fits into the outer tube’s groove.



9. Install:
- Dust seal “1”
(with the fork seal driver weight “2”)



Fork seal driver
90890-01442
Adjustable fork seal driver (36–46 mm)
YM-01442

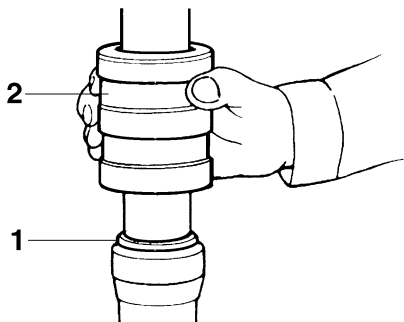

10. Fill:
- Front fork leg
(with the specified amount of the recommended fork oil)



Quantity
XV19S(C)/ XV19M(C)/
XV19CTS(C)/ XV19CTM(C):
571.0 cm³ (19.31 US oz) (20.10
Imp.oz)
XV19CS(C)/ XV19C(C):
755.0 cm³ (25.53 US oz) (26.58
Imp.oz)
Recommended oil
Yamaha fork oil 10WT

11. Measure:
- Front fork leg oil level “a”
(from the top of the inner tube, with the outer tube fully compressed and without the fork spring)
Out of specification → Correct.



Level
XV19S(C)/ XV19M(C)/
XV19CTS(C)/ XV19CTM(C):
124.0 mm (4.88 in)
XV19CS(C)/ XV19C(C):
117.0 mm (4.61 in)

- NOTE:**
- While filling the front fork leg, keep it upright.
 - After filling, slowly pump the front fork leg up and down to distribute the fork oil.

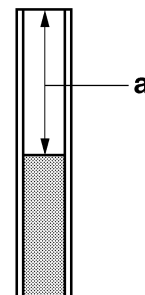

12. Install:
- Spring “1”
 - Spring seat “2”
 - Spacer
 - Cap bolt
(with O-ring)

- NOTE:**
- Install the spring with the smaller pitch facing up.
 - Before installing the cap bolt, lubricate its O-ring with grease.
 - Temporarily tighten the cap bolt.

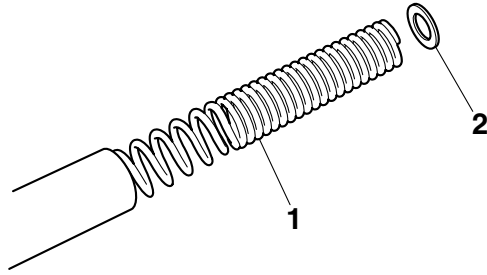

EAS23050

INSTALLING THE FRONT FORK LEGS (for XV19S(C)/ XV19M(C)/ XV19CTS(C)/ XV19CTM(C))

The following procedure applies to both of the front fork legs.

1. Install:

- Lower front fork cover “1”
- Front fork leg “2”
- Upper bracket “3”
Temporarily tighten the lower bracket pinch bolts and steering stem nut.

NOTE:

Make sure the inner tube end is flush with the top of the upper bracket.

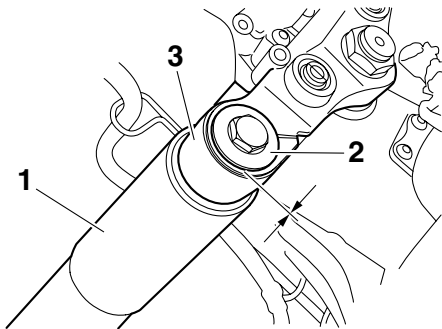

2. Tighten:

- Lower bracket pinch bolts



Lower bracket pinch bolt
23 Nm (2.3 m·kg, 17 ft·lb)

3. Remove:

- Upper bracket

4. Tighten:

- Lower front fork cover nuts



Lower front fork cover nut
7 Nm (0.7 m·kg, 5.1 ft·lb)

5. Install:

- Upper front fork cover “1”
- Upper bracket

NOTE:

Align the groove “a” in the upper front fork cover “1” with the lower front fork cover nut “2”.

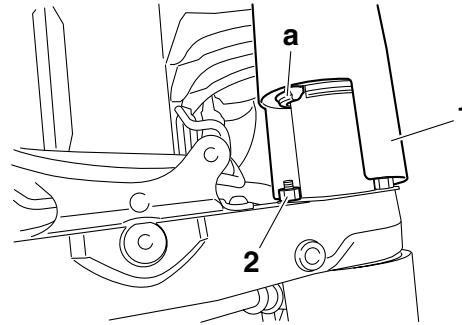

6. Tighten:

- Steering stem nut

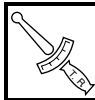

Steering stem nut
115 Nm (11.5 m·kg, 85 ft·lb)

- Cap bolt



Cap bolt
23 Nm (2.3 m·kg, 17 ft·lb)

- Upper bracket pinch bolts



Upper bracket pinch bolt
10 Nm (1.0 m·kg, 7.2 ft·lb)
LOCTITE®

NOTE:

Tighten the upper bracket pinch bolts to specification twice. Tighten the upper and lower bolts alternately, starting with the upper bolts.

- Upper bracket cover bolts



Upper bracket cover bolt
19 Nm (1.9 m·kg, 13 ft·lb)
LOCTITE®

- Upper bracket cover bolts



Upper bracket cover bolt
16 Nm (1.6 m·kg, 11 ft·lb)
LOCTITE®

EWA13680

WARNING

Make sure the brake hoses are routed properly.

EAS1D77008

INSTALLING THE FRONT FORK LEGS (for XV19CS(C)/ XV19C(C))

The following procedure applies to both of the front fork legs.

1. Install:

- Front fork leg “1”
Temporarily tighten the lower bracket pinch bolts and steering stem bolt.

NOTE:

Make sure the inner tube end is flush with the top of the upper bracket.

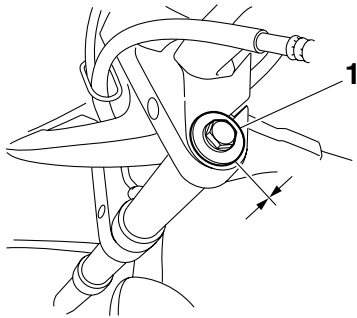

2. Tighten:

- Lower bracket pinch bolts



Lower bracket pinch bolt
23 Nm (2.3 m·kg, 17 ft·lb)

3. Tighten:

- Cap bolt



Cap bolt
23 Nm (2.3 m·kg, 17 ft·lb)

- Upper bracket pinch bolts



Upper bracket pinch bolt
19 Nm (1.9 m·kg, 13 ft·lb)

NOTE:

Tighten the upper bracket pinch bolts to specification twice. Tighten the upper and lower bolts alternately, starting with the upper bolts.

EWA13680



WARNING

Make sure the brake hoses are routed properly.

EAS23090

STEERING HEAD

Removing the lower bracket (for XV19S(C)/ XV19M(C)/ XV19CTS(C)/ XV19CTM(C))

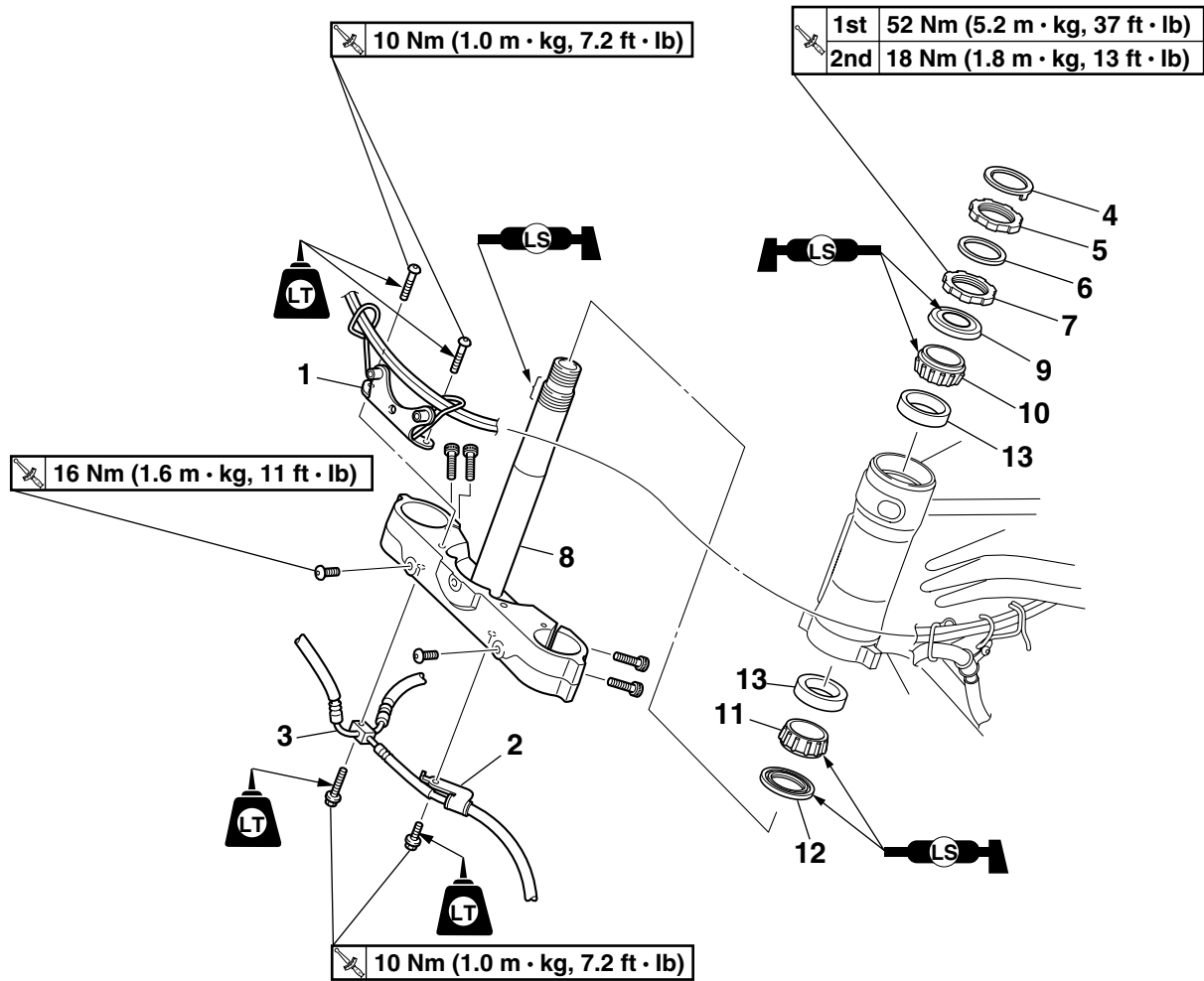

Order	Job/Parts to remove	Q'ty	Remarks
	Lower handlebar holder		Refer to "HANDLEBAR" on page 4-59.
	Upper bracket/Front fork legs		Refer to "FRONT FORK" on page 4-66.
1	Headlight bracket and throttle cable guide	1	
2	Front brake hose guide	1	
3	Front brake hose joint	1	
4	Lock washer	1	
5	Upper ring nut	1	
6	Rubber washer	1	
7	Lower ring nut	1	
8	Lower bracket	1	
9	Upper bearing cover	1	
10	Upper bearing	1	
11	Lower bearing	1	
12	Dust seal	1	

STEERING HEAD

Removing the lower bracket (for XV19S(C)/ XV19M(C)/ XV19CTS(C)/ XV19CTM(C))

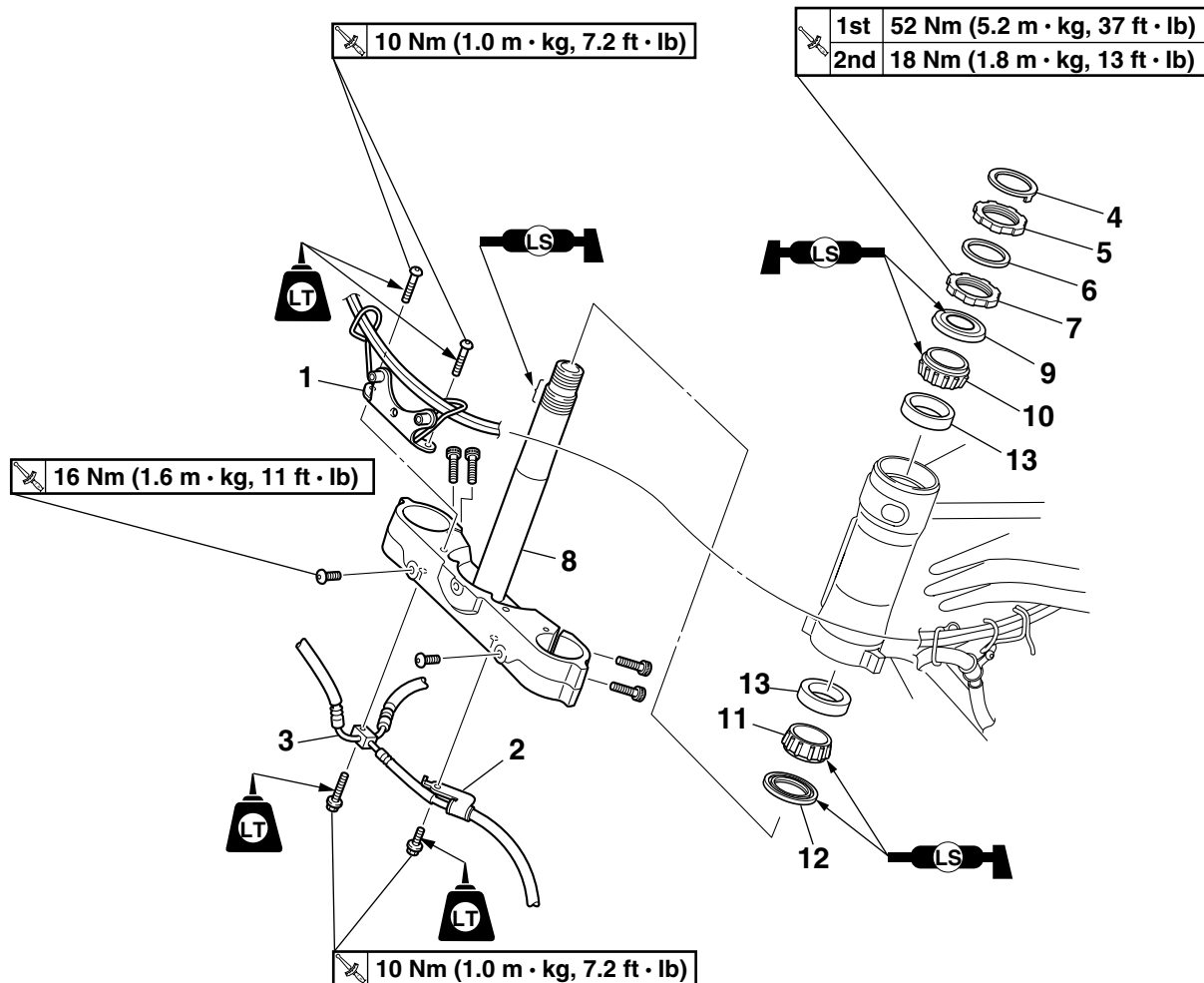

Order	Job/Parts to remove	Q'ty	Remarks
13	Bearing outer race	2	
			For installation, reverse the removal procedure.

STEERING HEAD

Removing the lower bracket (for XV19CS(C)/ XV19C(C))

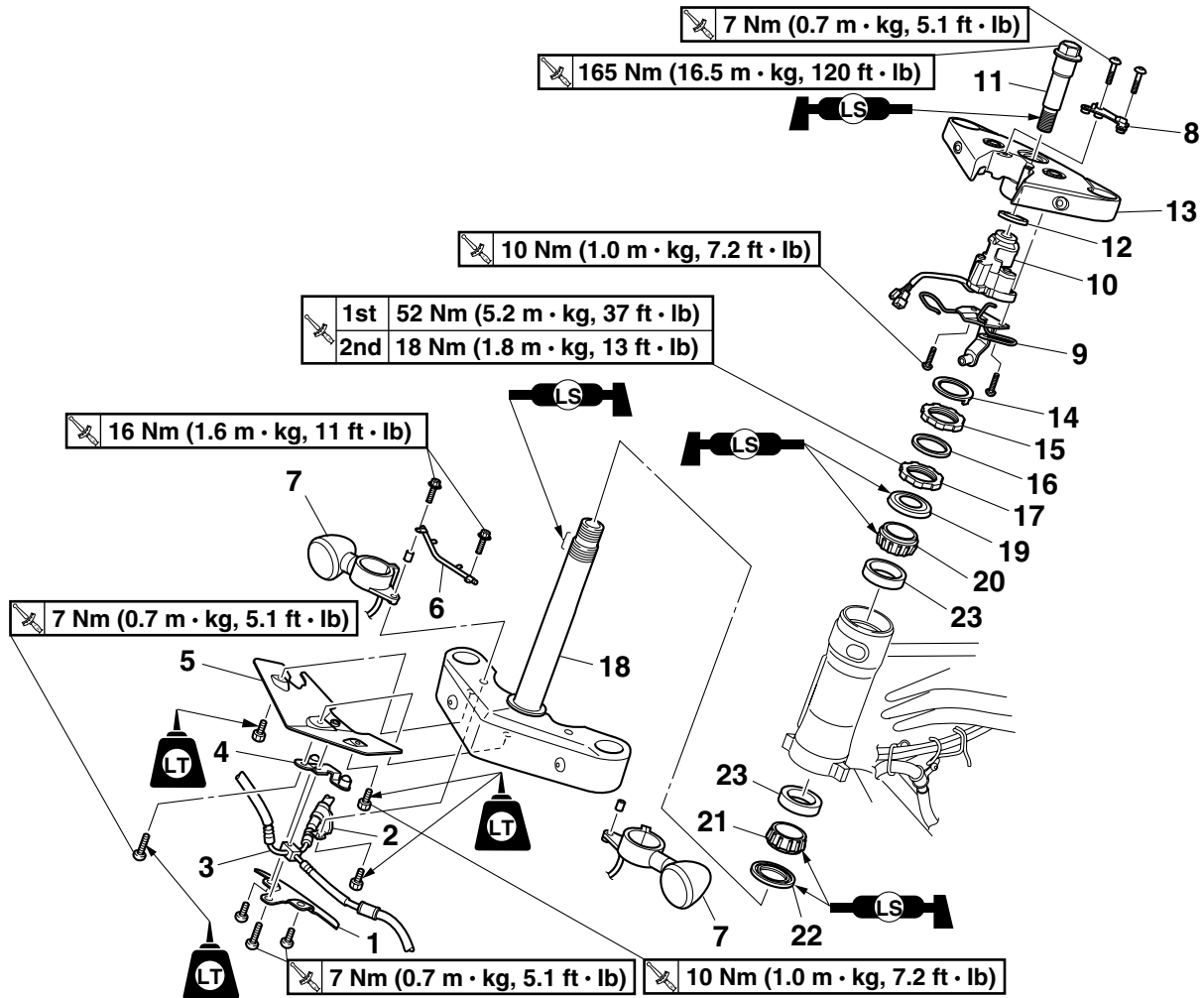

Order	Job/Parts to remove	Q'ty	Remarks
	Lower handlebar holders		Refer to "HANDLEBAR" on page 4-59.
	Front fork legs		Refer to "FRONT FORK" on page 4-66.
1	Plate	1	
2	Front brake hose guide	1	
3	Front brake hose joint	1	
4	Front brake hose joint holder	1	
5	Lower bracket cover	1	
6	Lead guide	1	
7	Front turn signal/position light	2	
8	Main switch cover bracket	1	
9	Cable guide	1	
10	Main switch	1	
11	Steering stem bolt	1	
12	Washer	1	
13	Upper bracket	1	
14	Lock washer	1	
15	Upper ring nut	1	

STEERING HEAD

Removing the lower bracket (for XV19CS(C)/ XV19C(C))

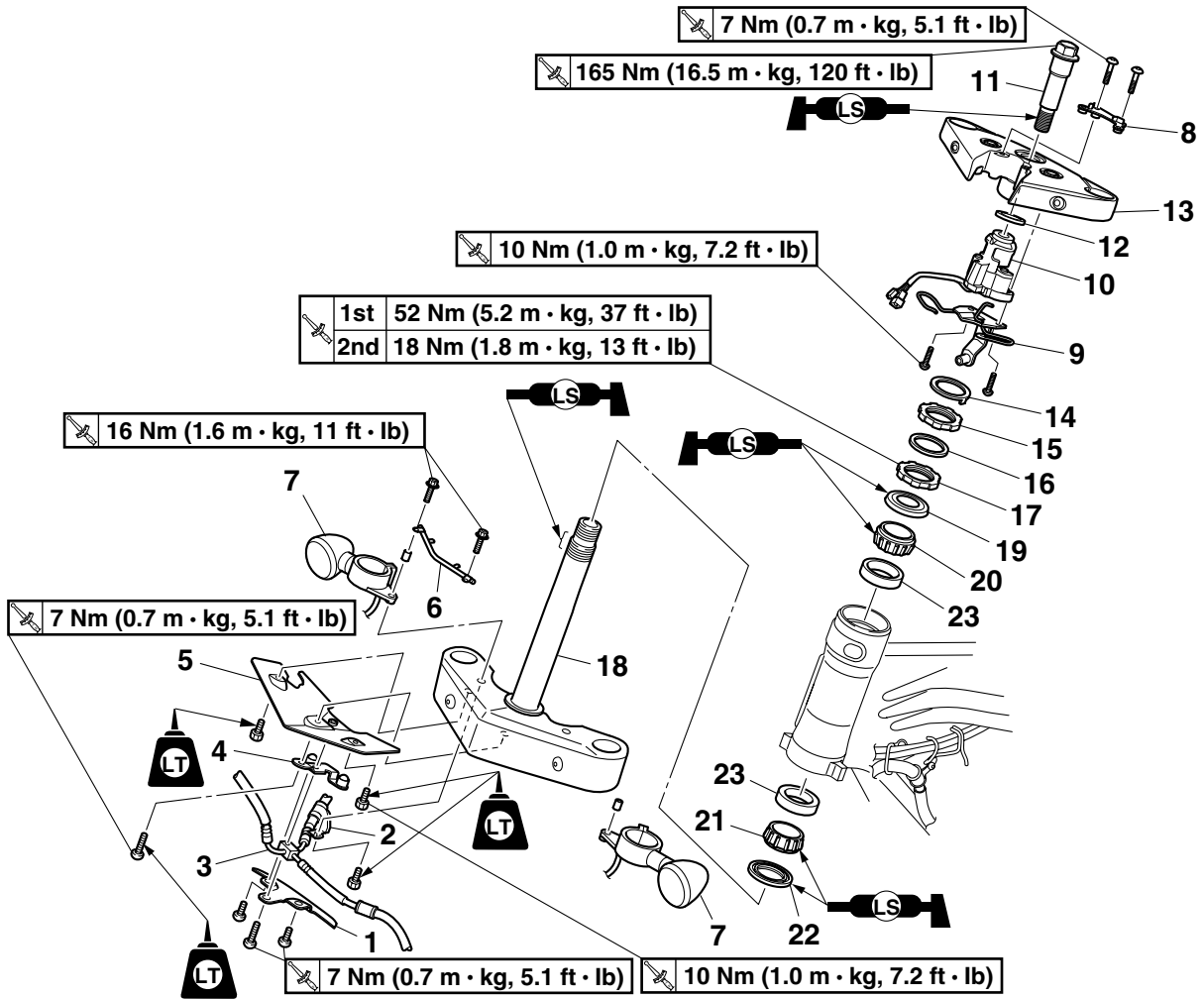

Order	Job/Parts to remove	Q'ty	Remarks
16	Rubber washer	1	
17	Lower ring nut	1	
18	Lower bracket	1	
19	Upper bearing cover	1	
20	Upper bearing	1	
21	Lower bearing	1	
22	Dust seal	1	
23	Bearing outer race	2	
			For installation, reverse the removal procedure.

EAS23110

REMOVING THE LOWER BRACKET

1. Stand the vehicle on a level surface.

EWA13120

WARNING

Securely support the vehicle so that there is no danger of it falling over.

2. Remove:

- Upper ring nut
- Rubber washer
- Lower ring nut "1"
- Lower bracket

EWA13730

WARNING

Securely support the lower bracket so that there is no danger of it falling.

NOTE:

Remove the lower ring nut with the steering nut wrench "2".

	Steering nut wrench 90890-01403 Spanner wrench YU-33975
---	--

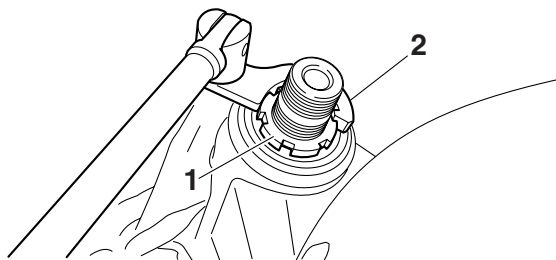

EAS23120

CHECKING THE STEERING HEAD

1. Wash:

- Bearings
- Bearing races

	Recommended cleaning solvent Kerosene
---	---

2. Check:

- Bearings
 - Bearing races
- Damage/pitting → Replace.

3. Replace:

- Bearings
- Bearing races

a. Remove the bearing races from the steering head pipe with a long rod "1" and hammer.

- b. Remove the bearing race from the lower bracket with a floor chisel "2" and hammer.
- c. Install a new dust seal and new bearing races.

ECA14270

CAUTION:

If the bearing race is not installed properly, the steering head pipe could be damaged.

NOTE:

- Always replace the bearings and bearing races as a set.
- Whenever the steering head is disassembled, replace the dust seal.

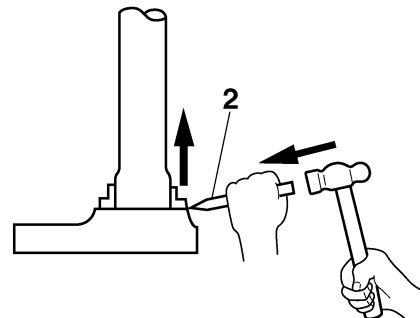
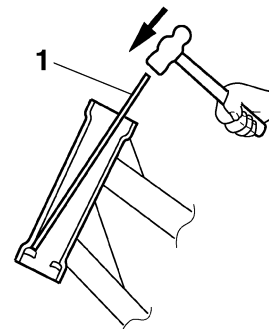

4. Check:

- Upper bracket
 - Lower bracket
- (along with the steering stem)
 Bends/cracks/damage → Replace.

EAS23140

INSTALLING THE STEERING HEAD (for XV19S(C)/ XV19M(C)/ XV19CTS(C)/ XV19TMX(C))

1. Lubricate:

- Upper bearing
- Lower bearing
- Bearing races

	Recommended lubricant Lithium-soap-based grease
---	---

2. Install:

- Lower ring nut “1”
- Rubber washer “2”
- Upper ring nut “3”
- Lock washer “4”

Refer to “CHECKING AND ADJUSTING THE STEERING HEAD” on page 3-27.

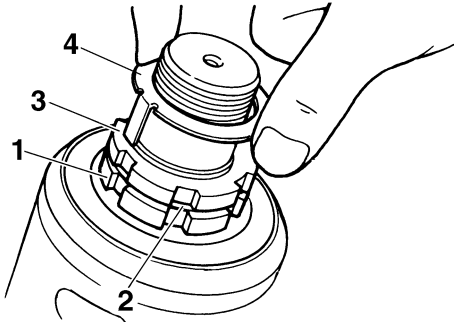

3. Install:

- Front brake hose joint “1”
- Front brake hose guide “2”

NOTE:

- Make sure that the projection “a” on the lower bracket contacts the side “b” of the front brake hose joint “1”.
- Align the projection “c” on the front brake hose guide with the hole “d” in the lower bracket.

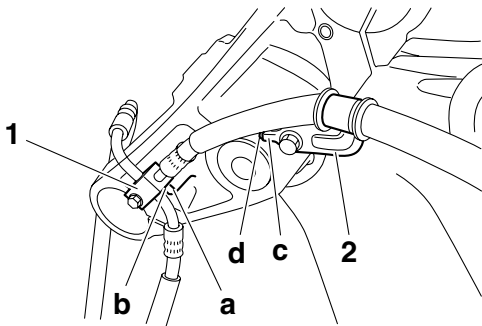

4. Install:

- Front fork legs
- Upper bracket

Refer to “FRONT FORK” on page 4-66.

EAS1D77009

INSTALLING THE STEERING HEAD (for XV19CS(C)/ XV19C(C))

1. Lubricate:

- Upper bearing
- Lower bearing
- Bearing races

	Recommended lubricant Lithium-soap-based grease
---	---

2. Install:

- Lower ring nut “1”
- Rubber washer “2”
- Upper ring nut “3”
- Lock washer “4”

Refer to “CHECKING AND ADJUSTING THE STEERING HEAD” on page 3-27.

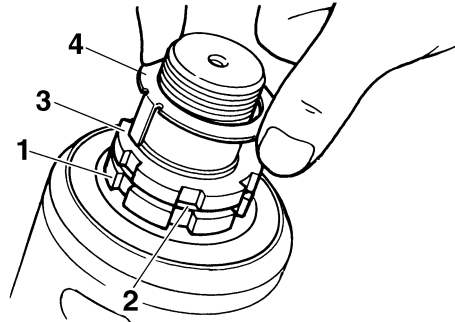

3. Install:

- Upper bracket
- Steering stem bolt

NOTE:

Temporarily tighten the steering stem bolt.

4. Install:

- Front fork legs
- Refer to “FRONT FORK” on page 4-66.

NOTE:

Temporarily tighten the upper and lower bracket pinch bolts.

5. Tighten:

- Steering stem bolt

	Steering stem bolt 165 Nm (16.5 m·kg, 120 ft·lb)
---	--

6. Install:

- Front brake hose guide “1”

NOTE:

Align the projection “a” on the front brake hose guide with the hole “b” in the lower bracket.

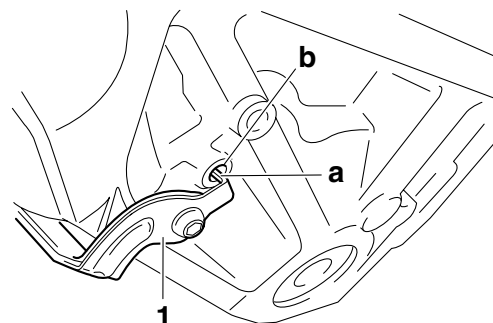

REAR SHOCK ABSORBER ASSEMBLY AND SWINGARM

ET1D71001

REAR SHOCK ABSORBER ASSEMBLY AND SWINGARM

Removing the rear shock absorber assembly and swingarm

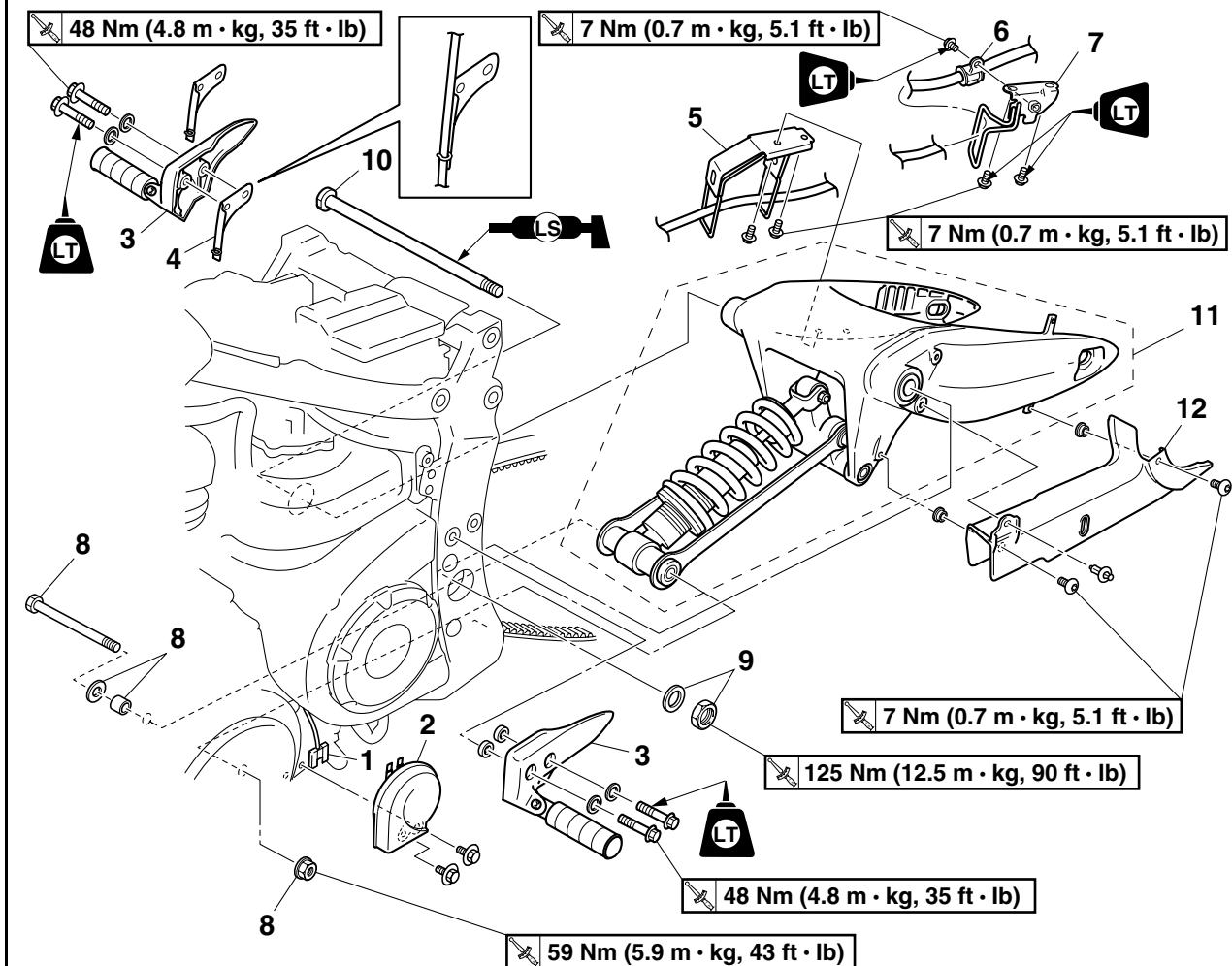

Order	Job/Parts to remove	Q'ty	Remarks
	Rear wheel		Refer to "REAR WHEEL" on page 4-27.
	Exhaust pipes		Refer to "ENGINE REMOVAL" on page 5-1.
	Brake master cylinder bracket		Refer to "REAR BRAKE" on page 4-47.
	Engine mounting nut (rear lower side)		Loosen. Refer to "ENGINE REMOVAL" on page 5-1.
1	Horn 1 coupler	1	Disconnect.
2	Horn 1	1	
3	Passenger footrest (left and right)	2	For XV19S(C)/ XV19M(C) only
4	O ₂ sensor lead guide	1	NOTE: Pass the O ₂ sensor lead through the guide.
5	Rear brake hose guide	1	For XV19S(C)/ XV19M(C)/ XV19CTS(C)/ XV19CTM(C)
6	Rear brake hose holder	1	For XV19CS(C)/ XV19C(C)
7	Rear brake hose guide	1	For XV19CS(C)/ XV19C(C)
8	Self-locking nut/Bolt/Spacer/Washer	1/1/1/1	

REAR SHOCK ABSORBER ASSEMBLY AND SWINGARM

Removing the rear shock absorber assembly and swingarm

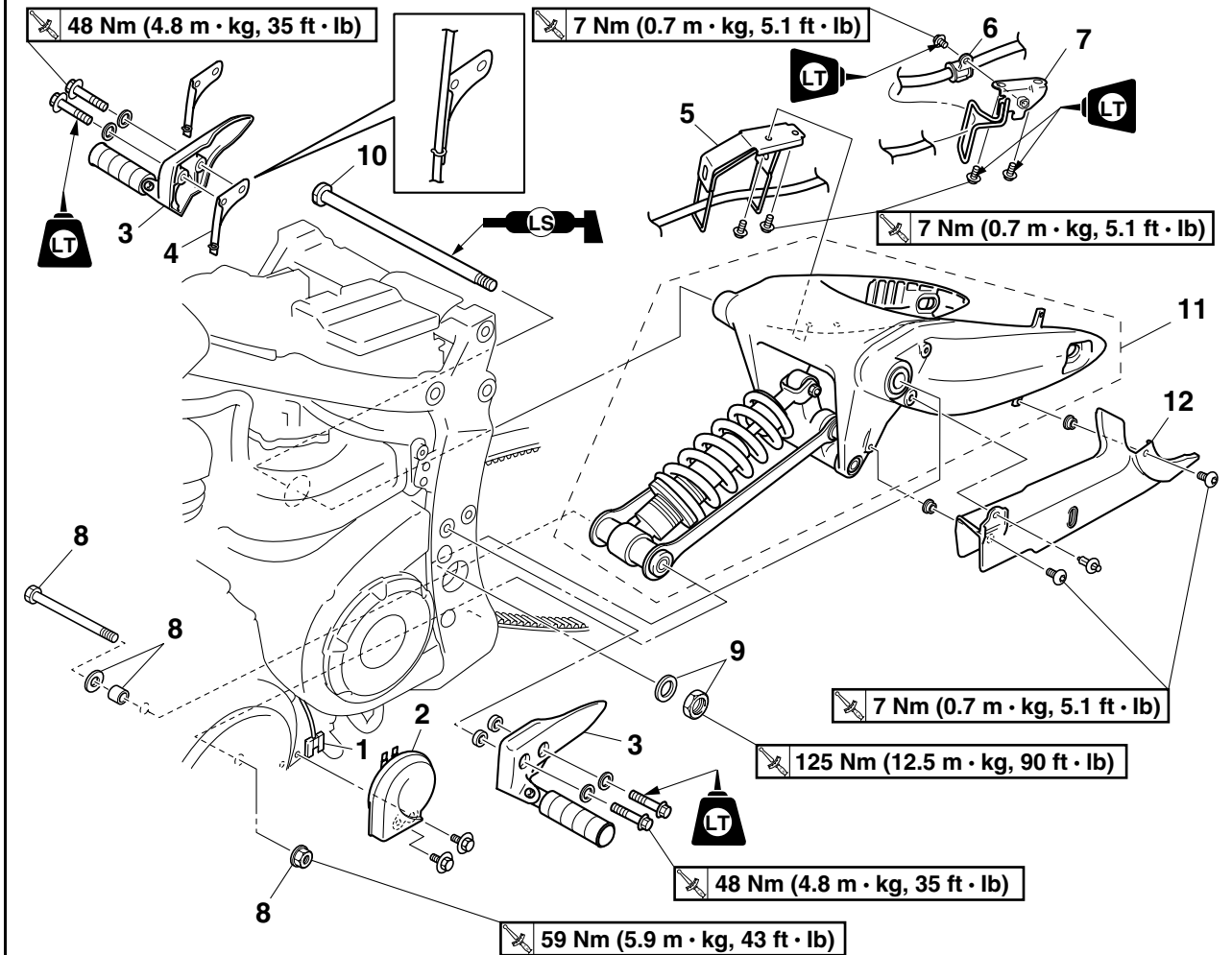

Order	Job/Parts to remove	Q'ty	Remarks
9	Pivot shaft nut/Washer	1/1	
10	Pivot shaft	1	
11	Rear shock absorber and swingarm assembly	1	
12	Lower drive belt cover	1	
			For installation, reverse the removal procedure.

REAR SHOCK ABSORBER ASSEMBLY AND SWINGARM

Removing the rear shock absorber and swingarm

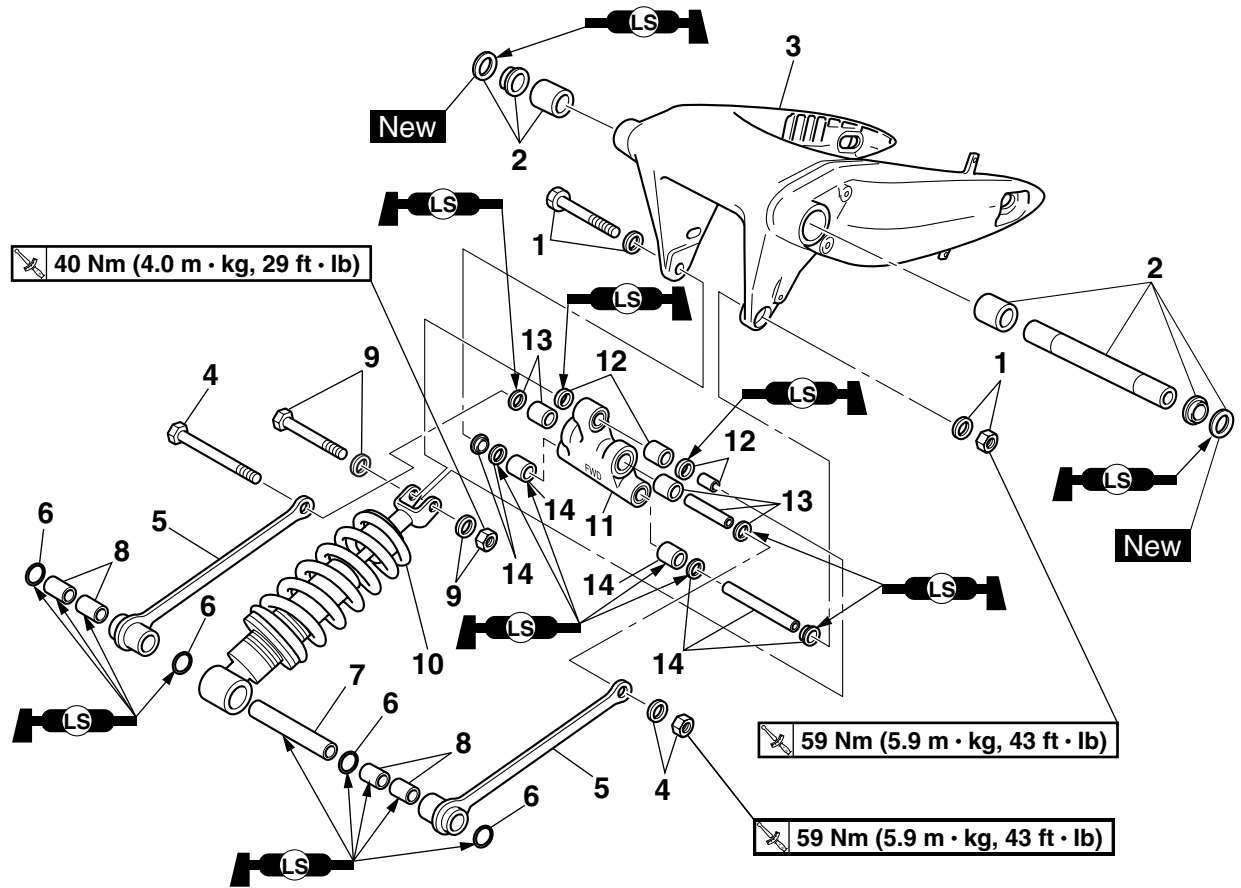

Order	Job/Parts to remove	Q'ty	Remarks
1	Self-locking nut/Washer/Bolt	1/2/1	
2	Oil seal/Collar/Bushing/Bearing	2/2/1/2	
3	Swingarm	1	
4	Self-locking nut/Washer/Bolt	1/1/1	
5	Connecting arm	2	
6	O-ring	4	
7	Spacer	1	
8	Bushing	4	
9	Self-locking nut/Washer/Bolt	1/2/1	
10	Rear shock absorber	1	
11	Relay arm	1	
12	Oil seal/Spacer/Bearing	2/1/1	
13	Oil seal/Spacer/Bearing	2/1/2	
14	Collar/Oil seal/Spacer/Bearing	2/2/1/2	
			For installation, reverse the removal procedure.

REAR SHOCK ABSORBER ASSEMBLY AND SWINGARM

EAS23180

HANDLING THE REAR SHOCK ABSORBER

EWA13740



WARNING

This rear shock absorber contains highly compressed nitrogen gas. Before handling the rear shock absorber, read and make sure you understand the following information. The manufacturer cannot be held responsible for property damage or personal injury that may result from improper handling of the rear shock absorber.

- Do not tamper or attempt to open the rear shock absorber.
- Do not subject the rear shock absorber to an open flame or any other source of high heat. High heat can cause an explosion due to excessive gas pressure.
- Do not deform or damage the rear shock absorber in any way. Rear shock absorber damage will result in poor damping performance.

EAS23190

DISPOSING OF A REAR SHOCK ABSORBER

1. Gas pressure must be released before disposing of a rear shock absorber. To release the gas pressure, drill a 2–3 mm (0.08–0.12 in) hole through the rear shock absorber at a point 15–20 mm (0.59–0.79 in) from its end as shown.

EWA13760



WARNING

Wear eye protection to prevent eye damage from released gas or metal chips.

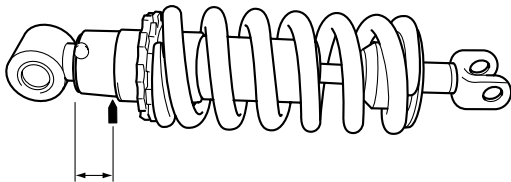

ET1D71002

REMOVING THE REAR SHOCK ABSORBER ASSEMBLY AND SWINGARM

1. Stand the vehicle on a level surface.

EWA13120



WARNING

Securely support the vehicle so that there is no danger of it falling over.

NOTE:

Place the vehicle on a suitable stand so that the rear wheel is elevated.

2. Loosen:

- Engine mounting nut (rear lower side)
Refer to “ENGINE REMOVAL” on page 5-1.

NOTE:

Because there is force being exerted on the engine mounting bracket (left and right rear lower sides), it is necessary to loosen the engine mounting nut (rear lower side) in order to create some space between the connecting arms and engine bracket before removing the rear shock absorber and swingarm.

3. Remove:

- Connecting arm bolt (frame side)

NOTE:

When removing the connecting arm bolt (frame side), hold the swingarm so that it does not drop down.

4. Measure:

- Swingarm side play
- Swingarm vertical movement



- a. Measure the tightening torque of the pivot shaft nut.

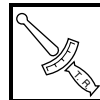

Pivot shaft nut

125 Nm (12.5 m·kg, 90 ft·lb)

- b. Measure the swingarm side play “A” by moving the swingarm from side to side.
- c. If the swingarm side play is out of specification, check the spacers, bearings, washers, and oil seals.



Swingarm side play (at the end of the swingarm)

1.0 mm (0.04 in)

- d. Check the swingarm vertical movement “B” by moving the swingarm up and down. If swingarm vertical movement is not smooth or if there is binding, check the spacers, bearings, washers, and oil seals.

REAR SHOCK ABSORBER ASSEMBLY AND SWINGARM

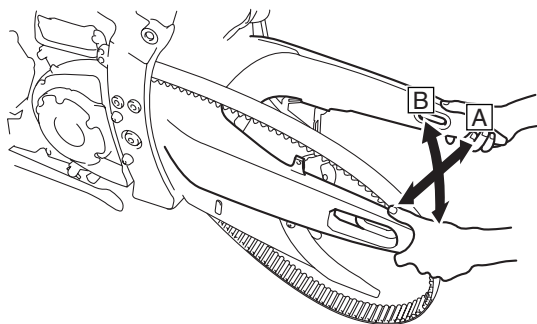

EAS23360

CHECKING THE SWINGARM

1. Check:
 - Swingarm
Bends/cracks/damage → Replace.
2. Check:
 - Pivot shaft
Roll the pivot shaft on a flat surface.
Bends → Replace.

EWA13770



WARNING

Do not attempt to straighten a bent pivot shaft.



EAS23240

CHECKING THE REAR SHOCK ABSORBER ASSEMBLY

1. Check:
 - Rear shock absorber rod
Bends/damage → Replace the rear shock absorber assembly.
 - Rear shock absorber
Gas leaks/oil leaks → Replace the rear shock absorber assembly.
 - Spring
Damage/wear → Replace the rear shock absorber assembly.
 - Bushing
Damage/wear → Replace the rear shock absorber assembly.
 - Spacer
Damage/scratches → Replace.
 - Bolts
Bends/damage/wear → Replace.

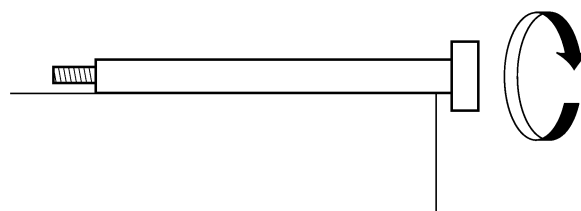

3. Wash:
 - Pivot shaft
 - Bushing
 - Washer
 - Bearings
 - Collars



EAS23260

CHECKING THE CONNECTING ARM AND RELAY ARM

1. Check:
 - Connecting arms
 - Relay arm
Damage/wear → Replace.
2. Check:
 - Bearings
 - Oil seals
Damage/pitting → Replace.
3. Check:
 - Bushings
Damage/wear → Replace.
4. Check:
 - Spacers
 - Collars
Damage/scratches → Replace.

4. Check:
 - Washer
 - Oil seals
 - Bushing
Damage/wear → Replace.
 - Bearings
Damage/pitting → Replace.
 - Collar
Damage/scratches → Replace.

ET1D71003

INSTALLING THE RELAY ARM, REAR SHOCK ABSORBER ASSEMBLY AND CONNECTING ARMS

1. Lubricate:
 - Oil seals



REAR SHOCK ABSORBER ASSEMBLY AND SWINGARM

2. Install:

- Bearings "1", "2", "3"
(to the relay arm)
- Oil seals "4", "5"
(to the relay arm)



Installed depth "a"
4.5 mm (0.18 in)
Installed depth "b"
1.0 mm (0.04 in)
Installed depth "c"
6.0 mm (0.24 in)
Installed depth "d"
2.5 mm (0.10 in)

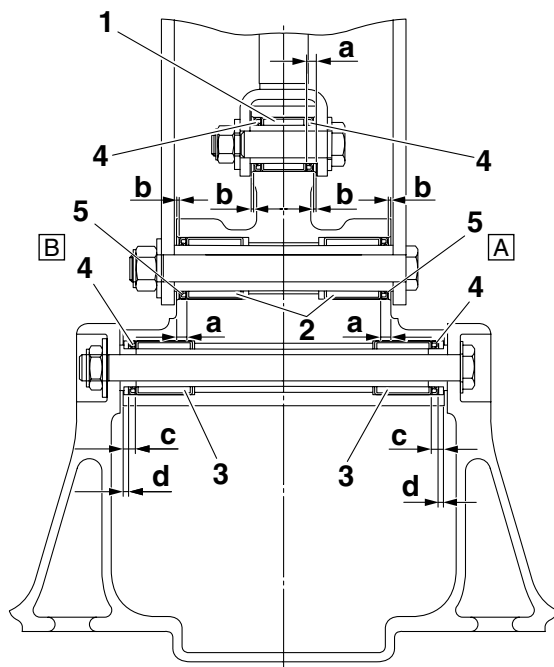

- A. Right side
- B. Left side

3. Lubricate:

- Bushings
- Oil seals
- O-rings
- Collar

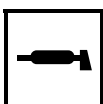

Recommended lubricant
Lithium-soap-based grease

NOTE:

Apply grease only to the collar between the connecting arms and rear shock absorber.

4. Install:

- Bushings "1"
(to connecting arms)

- Spacer "2"

EC1D71010

CAUTION:

When inserting the spacer into the connecting arms and the rear shock absorber, be careful not to damage the bushings and O-rings.

NOTE:

Install the bushings so that the slits "b" in the bushings are within the areas shown in the illustration.



Installed depth "a"
4.5 mm (0.18 in)

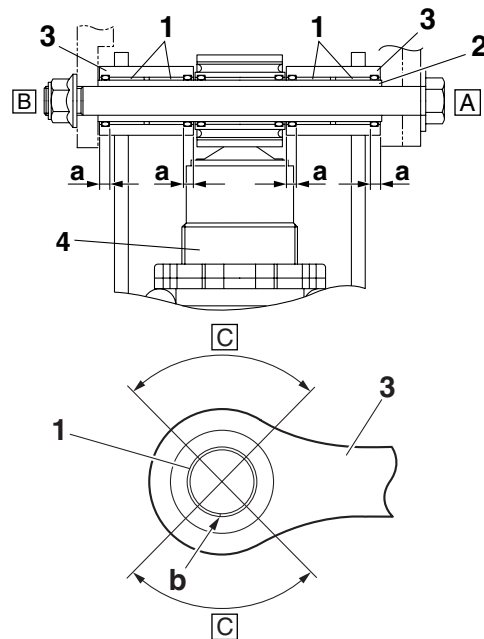

- 3. Connecting arm
- 4. Rear shock absorber
- A. Right side
- B. Left side
- C. 90°

5. Install:

- Connecting arms
- Rear shock absorber assembly
(to relay arm)
- Relay arm
(to the swingarm)

NOTE:

Be sure to face the "FWD" mark "a" on the relay arm "1" toward the front of the vehicle and to face the label "b" on the rear shock absorber "2" downward.

REAR SHOCK ABSORBER ASSEMBLY AND SWINGARM

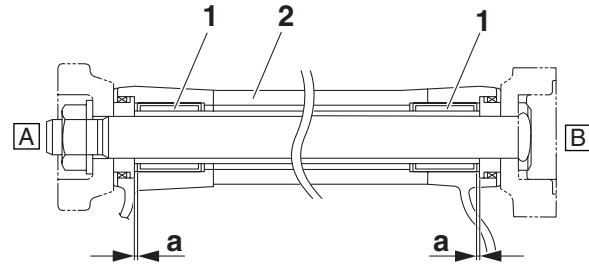
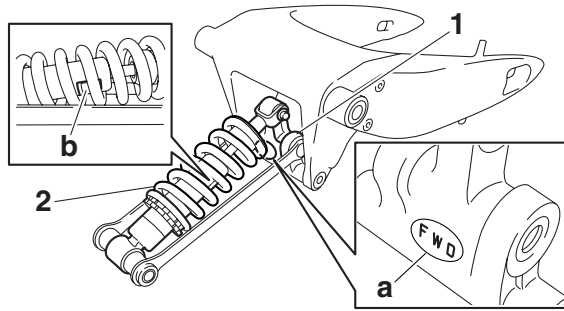

6. Tighten:

- Connecting-arm-to-relay-arm nut



Connecting-arm-to-relay-arm nut
59 Nm (5.9 m·kg, 43 ft·lb)

- Rear-shock-absorber-assembly-to-relay-arm nut

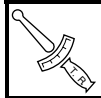

Rear-shock-absorber-assembly-to-relay-arm nut
40 Nm (4.0 m·kg, 29 ft·lb)

- Relay-arm-to-swingarm nut



Relay-arm-to-swingarm nut
59 Nm (5.9 m·kg, 43 ft·lb)

EAS28780

INSTALLING THE SWINGARM

1. Lubricate:

- Bearings
- Collars
- Oil seals
- Pivot shaft

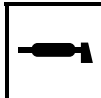

Recommended lubricant
Lithium-soap-based grease

2. Install:

- Bearings "1"
(to swingarm)



Installed depth "a"
1.0 mm (0.04 in)

2. Swingarm

- A. Left side
- B. Right side

3. Install:

- Pivot shaft
- Washer
- Pivot shaft nut

NOTE:

Temporarily tighten the pivot shaft nut.

4. Install:

- Connecting arm bolt (front side)

NOTE:

When installing the connecting arm bolt, hold the swingarm so that it does not drop down.

5. Tighten:

- Pivot shaft nut
- Engine mounting nut (rear lower side)
- Connecting arm nut (front side)



Pivot shaft nut
125 Nm (12.5 m·kg, 90 ft·lb)
Engine mounting nut (rear lower side)
98 Nm (9.8 m·kg, 71 ft·lb)
Connecting arm nut (front side)
59 Nm (5.9 m·kg, 43 ft·lb)

6. Adjust:

- Drive belt slack
Refer to "ADJUSTING THE DRIVE BELT SLACK" on page 3-26.

EAS23510

BELT DRIVE

Removing the drive belt and drive pulley

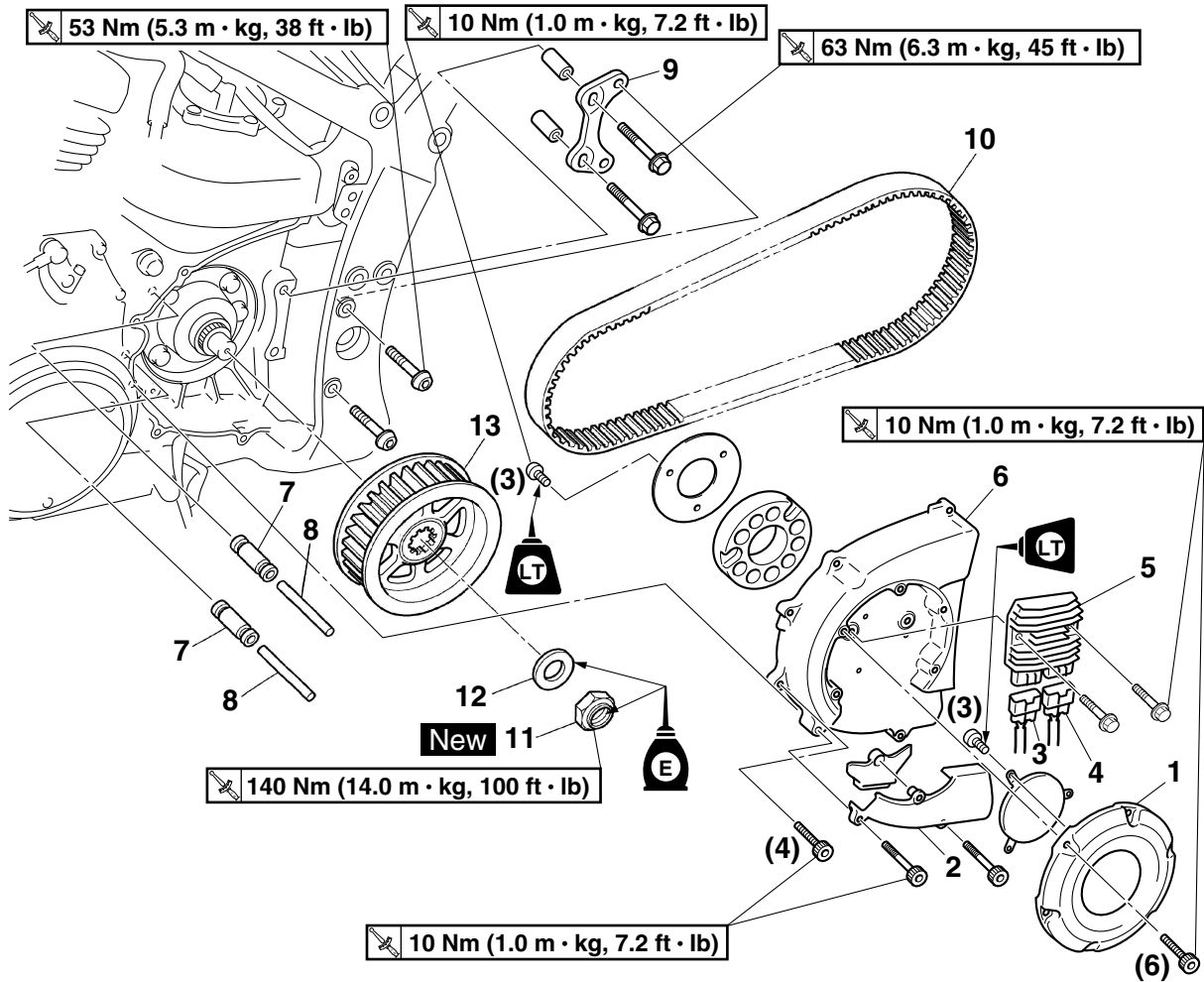

Order	Job/Parts to remove	Q'ty	Remarks
	Rear wheel		Refer to "REAR WHEEL" on page 4-27.
	Rear shock absorber assembly and swingarm		Refer to "REAR SHOCK ABSORBER ASSEMBLY AND SWINGARM" on page 4-83.
1	Rectifier/regulator cover	1	
2	Lead cover	1	
3	Stator coil coupler	1	Disconnect.
4	Rectifier/regulator coupler	1	Disconnect.
5	Rectifier/regulator	1	
6	Drive pulley cover	1	
7	Slider	2	
8	Dowel pin	2	
9	Transfer gear case bracket	1	
10	Drive belt	1	
11	Drive pulley nut	1	
12	Conical spring washer	1	

Removing the drive belt and drive pulley

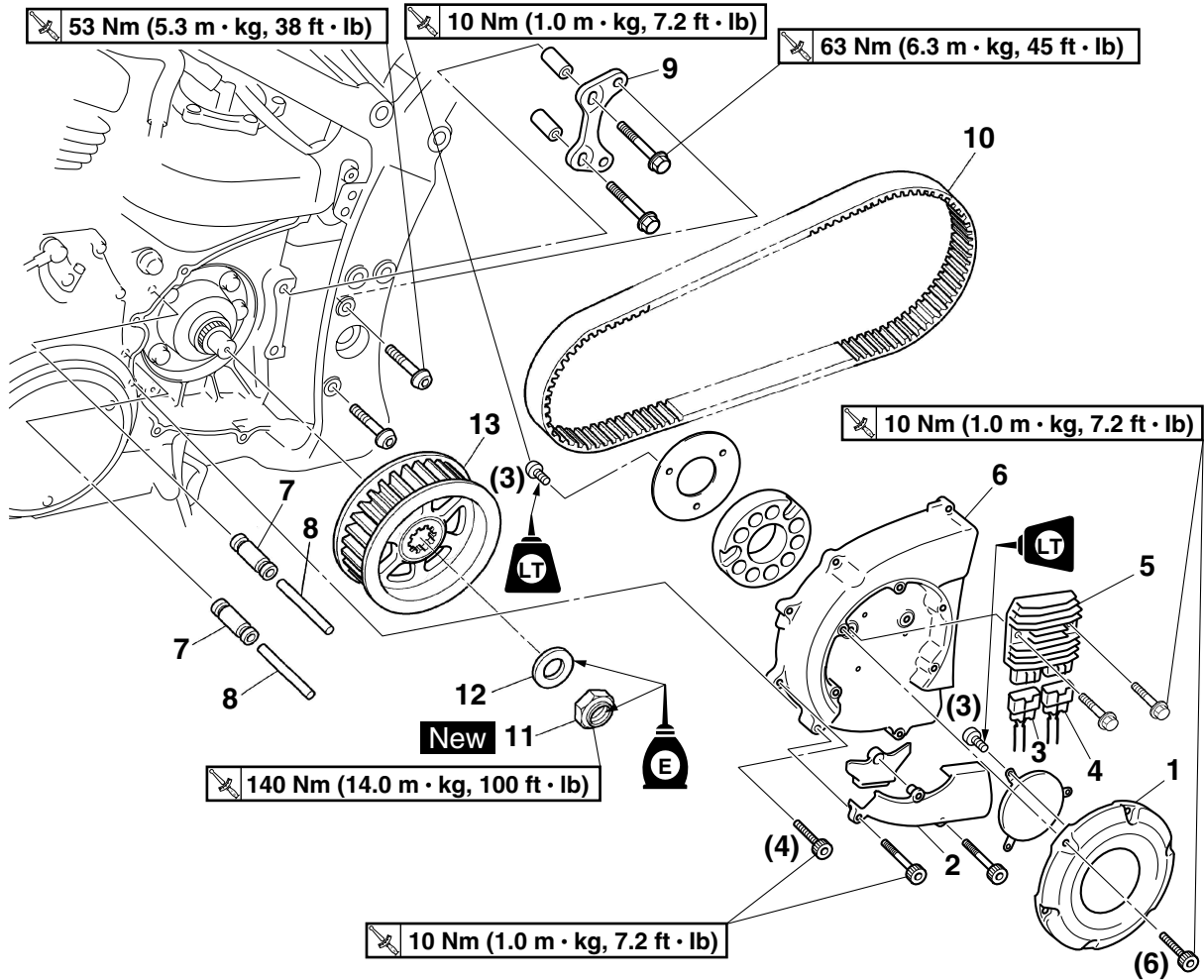

Order	Job/Parts to remove	Q'ty	Remarks
13	Drive pulley	1	
			For installation, reverse the removal procedure.

EAS23520

REMOVING THE DRIVE BELT AND DRIVE PULLEY

NOTE: _____

Loosen the drive pulley nut before removing the rear wheel.

1. Loosen:

- Drive pulley nut “1”

NOTE: _____

When loosening the drive pulley nut, press down on the brake pedal so the drive pulley does not move.

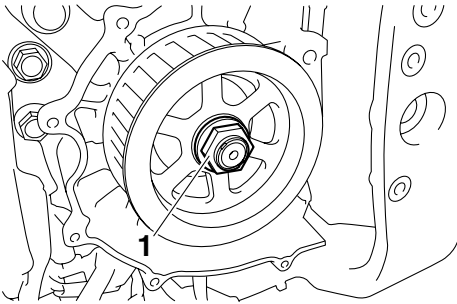

EAS23530

CHECKING THE DRIVE BELT

1. Clean:

- Drive belt

- Wipe the drive belt with a clean cloth.
- Put the drive belt in a mixture of mild detergent and water. Then, remove any dirt from the drive belt.
- Remove the drive belt from the mixture and rinse it off with clean water. Then, let the drive belt thoroughly dry.

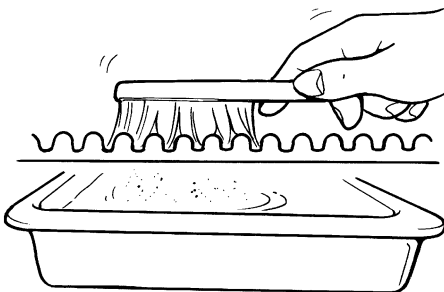

2. Check:

- Drive belt

ECA14690

CAUTION: _____

- To protect the drive belt from damage, handle it with care.

- The drive belt can not be bent smaller than 127 mm (5 in) “a”.
- The removed drive belt can not be twisted inside out.

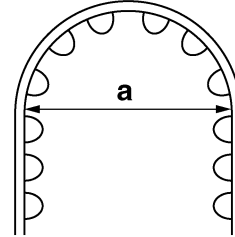

3. Check:

- Drive pulley
 - Rear wheel pulley
- Bent teeth → Replace the drive belt and pulleys as a set.

EAS23540

INSTALLING THE DRIVE BELT AND DRIVE PULLEY

1. Install:

- Drive pulley “1”
- Conical spring washer “2”
- Drive pulley nut “3” **New**

NOTE: _____

- Install the conical spring washer “2” with the “OUT” mark “a” facing out.
- Apply engine oil to the conical spring washer and drive pulley nut.

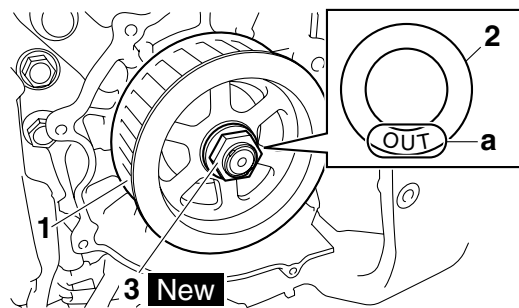

2. Install:

- Drive belt

ECA14710

CAUTION: _____

Install the drive belt facing the same way it was removed.

Do not twist the drive belt when installing it.

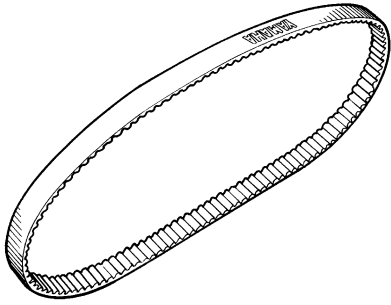

3. Install:

- Swingarm
- Rear shock absorber
Refer to “REAR SHOCK ABSORBER ASSEMBLY AND SWINGARM” on page 4-83.
- Rear wheel
Refer to “REAR WHEEL” on page 4-27.

4. Tighten:

- Drive pulley nut



Drive pulley nut
140 Nm (14.0 m·kg, 100 ft·lb)

NOTE:

- When tightening the drive pulley nut, press down on the brake pedal so the drive pulley does not move.
- Stake the drive pulley nut “1” at a cutout “a” in the middle driven shaft.

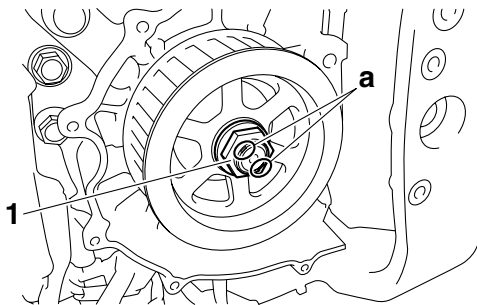

5. Adjust:

- Drive belt slack
Refer to “ADJUSTING THE DRIVE BELT SLACK” on page 3-26.

ENGINE

ENGINE REMOVAL	5-1
INSTALLING THE SHIFT PEDAL ASSEMBLY	5-8
CHECKING THE OIL COOLER (for XV19S(C)/ XV19M(C)/ XV19CTS(C)/ XV19CTM(C))	5-10
REMOVING THE ENGINE	5-15
INSTALLING THE ENGINE.....	5-15
CAMSHAFTS	5-17
REMOVING THE CYLINDER HEAD COVERS	5-24
REMOVING THE ROCKER ARMS, PUSH RODS AND VALVE LIFTERS	5-24
REMOVING THE CAMSHAFTS.....	5-24
CHECKING THE CAMSHAFTS	5-26
CHECKING THE ROCKER ARMS AND ROCKER ARM SHAFTS	5-27
CHECKING THE ROCKER ARM BASES	5-28
CHECKING THE PUSH RODS	5-28
CHECKING THE VALVE LIFTERS AND VALVE LIFTER CASES	5-28
CHECKING THE PUSH ROD COVER.....	5-29
CHECKING THE DECOMPRESSION SYSTEM.....	5-29
CHECKING THE DECOMPRESSION CAM SPRING.....	5-29
CHECKING THE OIL DELIVERY PIPE.....	5-30
INSTALLING THE CAMSHAFTS	5-30
BLEEDING A VALVE LIFTER	5-32
INSTALLING THE VALVE LIFTERS	5-33
INSTALLING THE ROCKER ARMS AND PUSH RODS.....	5-34
INSTALLING THE CYLINDER HEAD COVERS	5-35
INSTALLING THE SHIFT PEDAL ASSEMBLY (for XV19S(C)/ XV19M(C)/ XV19CTS(C)/ XV19CTM(C))	5-35
CYLINDER HEADS	5-36
REMOVING THE CYLINDER HEADS	5-38
CHECKING THE CYLINDER HEADS.....	5-38
CHECKING THE OIL PIPE	5-38
INSTALLING THE CYLINDER HEADS.....	5-39
VALVES AND VALVE SPRINGS	5-41
REMOVING THE VALVES.....	5-42
CHECKING THE VALVES AND VALVE GUIDES	5-42
CHECKING THE VALVE SEATS	5-44
CHECKING THE VALVE SPRINGS.....	5-45
INSTALLING THE VALVES	5-46
CYLINDERS AND PISTONS	5-48
REMOVING THE PISTON	5-49
CHECKING THE CYLINDERS AND PISTONS	5-49
CHECKING THE PISTON RINGS.....	5-50
CHECKING THE PISTON PINS.....	5-51
INSTALLING THE PISTONS AND CYLINDERS	5-51

CLUTCH	5-53
REMOVING THE CLUTCH	5-64
REMOVING THE PRIMARY DRIVE GEAR	5-64
REMOVING THE LEFT BALANCER DRIVE GEAR	5-64
CHECKING THE FRICTION PLATES.....	5-65
CHECKING THE CLUTCH PLATES	5-65
CHECKING THE CLUTCH SPRING PLATE.....	5-65
CHECKING THE CLUTCH HOUSING	5-66
CHECKING THE CLUTCH BOSS.....	5-66
CHECKING THE PRESSURE PLATE	5-66
CHECKING THE CLUTCH PUSH RODS	5-66
CHECKING THE PRIMARY DRIVE GEAR.....	5-66
CHECKING THE PRIMARY DRIVEN GEAR	5-66
CHECKING THE LEFT BALANCER GEARS.....	5-66
INSTALLING THE LEFT BALANCER DRIVE GEAR.....	5-67
INSTALLING THE PRIMARY DRIVE GEAR.....	5-68
INSTALLING THE CLUTCH.....	5-69
DISASSEMBLING THE CLUTCH MASTER CYLINDER	5-70
CHECKING THE CLUTCH MASTER CYLINDER.....	5-70
ASSEMBLING THE CLUTCH MASTER CYLINDER	5-71
INSTALLING THE CLUTCH MASTER CYLINDER.....	5-71
REMOVING THE CLUTCH RELEASE CYLINDER	5-72
CHECKING THE CLUTCH RELEASE CYLINDER	5-72
ASSEMBLING THE CLUTCH RELEASE CYLINDER.....	5-73
INSTALLING THE CLUTCH RELEASE CYLINDER.....	5-73
SHIFT SHAFT	5-75
CHECKING THE SHIFT SHAFT	5-76
CHECKING THE STOPPER LEVER	5-76
INSTALLING THE SHIFT SHAFT	5-76
GENERATOR AND STARTER CLUTCH	5-77
REMOVING THE GENERATOR.....	5-79
REMOVING THE STARTER CLUTCH	5-79
CHECKING THE STARTER CLUTCH	5-79
CHECKING THE TORQUE LIMITER.....	5-80
INSTALLING THE STARTER CLUTCH	5-80
INSTALLING THE GENERATOR.....	5-80
ELECTRIC STARTER	5-82
CHECKING THE STARTER MOTOR	5-84
ASSEMBLING THE STARTER MOTOR.....	5-85
TRANSFER GEAR CASE	5-86
REMOVING THE MIDDLE DRIVEN SHAFT.....	5-91
CHECKING THE MIDDLE DRIVE	5-91
CHECKING THE OIL STRAINER	5-91
CHECKING THE TRANSFER GEAR OIL PUMP	5-91
CHECKING THE OIL PIPES	5-92
ASSEMBLING THE TRANSFER GEAR OIL PUMP	5-92
INSTALLING THE TRANSFER GEAR CASE.....	5-92

CRANKCASE	5-94
DISASSEMBLING THE CRANKCASE	5-97
CHECKING THE CRANKCASE	5-97
CHECKING THE BEARINGS AND OIL SEAL	5-97
CHECKING THE OIL DELIVERY PIPE AND OIL PIPE	5-97
CHECKING THE OIL STRAINERS	5-97
CHECKING THE ENGINE OIL PUMP DRIVEN GEAR.....	5-97
INSTALLING THE BEARING RETAINERS.....	5-98
ASSEMBLING THE CRANKCASE.....	5-98
OIL PUMP	5-100
CHECKING THE OIL PUMP	5-103
CHECKING THE RELIEF VALVE	5-103
CHECKING THE BALL SPRING AND RELIEF VALVE SPRING	5-103
CHECKING THE OIL STRAINER	5-104
ASSEMBLING THE OIL PUMP	5-104
INSTALLING THE OIL PUMP	5-105
CRANKSHAFT	5-106
REMOVING THE CONNECTING RODS	5-107
CHECKING THE CRANKSHAFT AND CONNECTING RODS.....	5-107
INSTALLING THE CONNECTING RODS.....	5-110
INSTALLING THE CRANKSHAFT ASSEMBLY.....	5-111
TRANSMISSION	5-112
CHECKING THE SHIFT FORKS.....	5-116
CHECKING THE SHIFT DRUM ASSEMBLY.....	5-116
CHECKING THE TRANSMISSION.....	5-116
ASSEMBLING THE MAIN AXLE AND DRIVE AXLE	5-117
INSTALLING THE SHIFT FORKS AND SHIFT DRUM ASSEMBLY	5-117

EAS23710

ENGINE REMOVAL

Removing the muffler and exhaust pipes (for XV19S(C)/ XV19M(C)/ XV19CTS(C)/ XV19CTM(C))

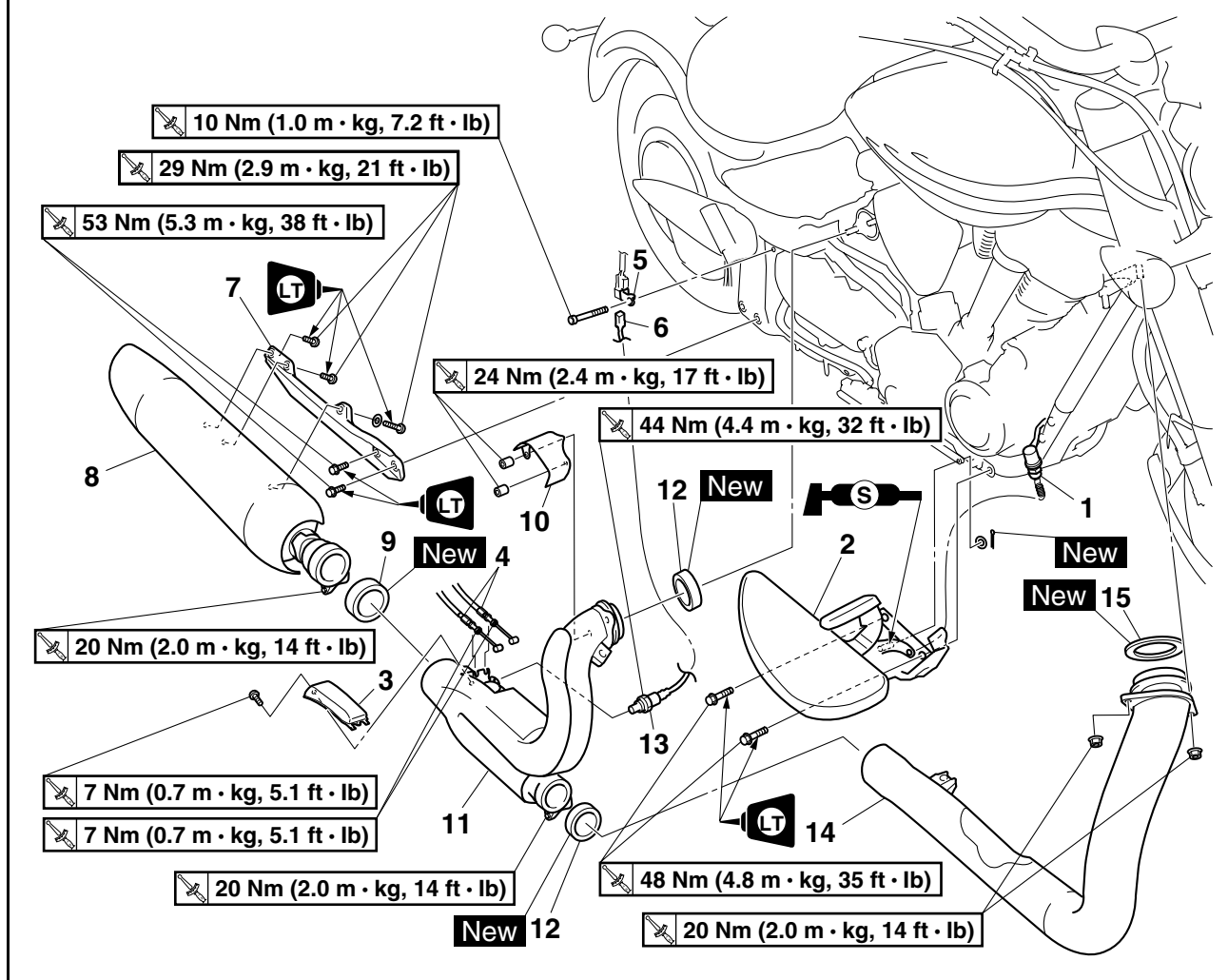

Order	Job/Parts to remove	Q'ty	Remarks
1	Rear brake light switch	1	
2	Right rider footrest assembly	1	
3	EXUP valve pulley cover	1	
4	EXUP cable	2	Disconnect.
5	O ₂ sensor coupler holder	1	
6	O ₂ sensor coupler	1	Disconnect.
7	Muffler bracket	1	
8	Muffler	1	
9	Gasket	1	
10	Rear exhaust pipe cover	1	
11	Rear exhaust pipe	1	
12	Gasket	2	
13	O ₂ sensor	1	
14	Front exhaust pipe	1	

ENGINE REMOVAL

Removing the muffler and exhaust pipes (for XV19S(C)/ XV19M(C)/ XV19CTS(C)/ XV19CTM(C))

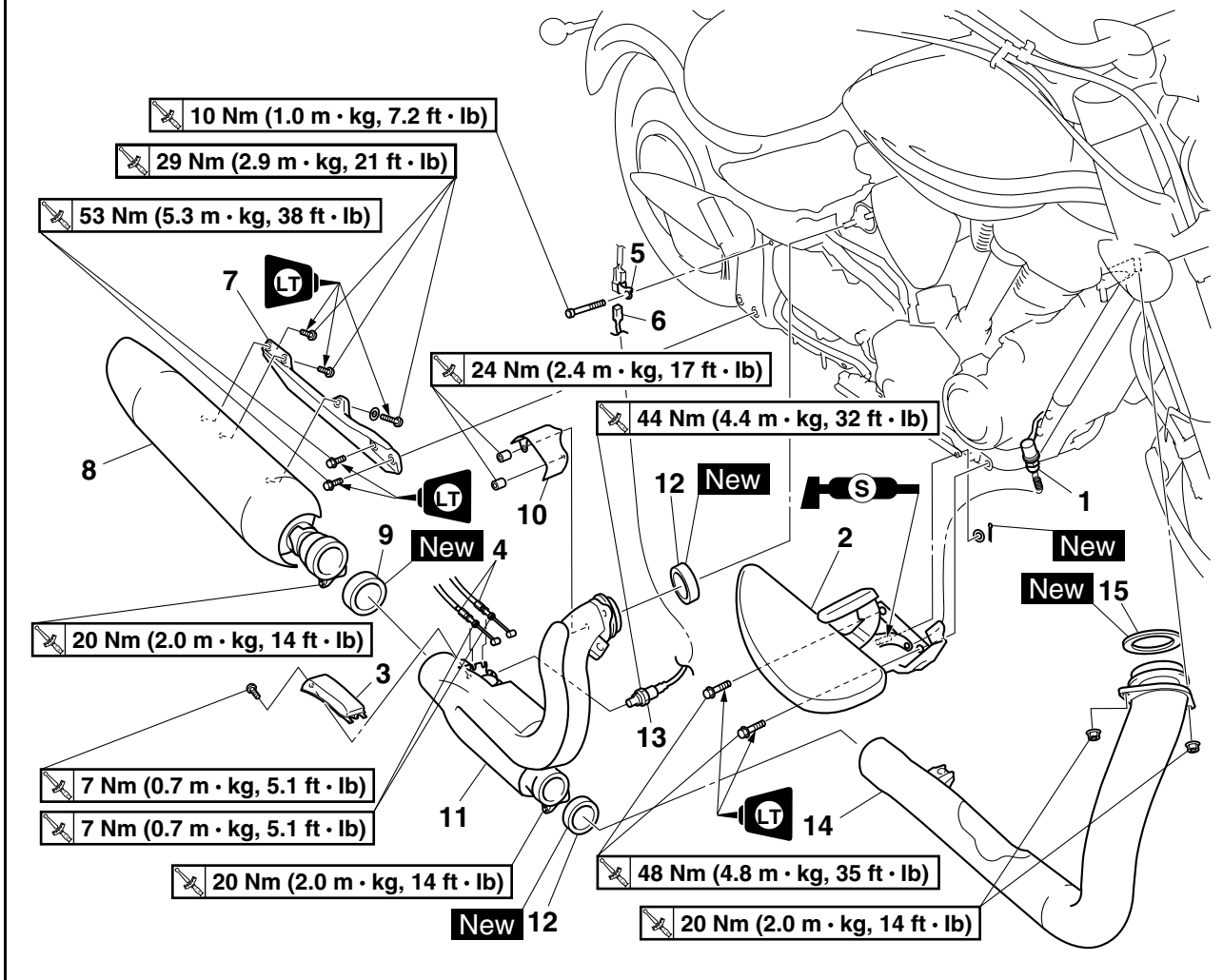

Order	Job/Parts to remove	Q'ty	Remarks
15	Gasket	1	
			For installation, reverse the removal procedure.

ENGINE REMOVAL

Removing the muffler and exhaust pipes (for XV19CS(C)/ XV19C(C))

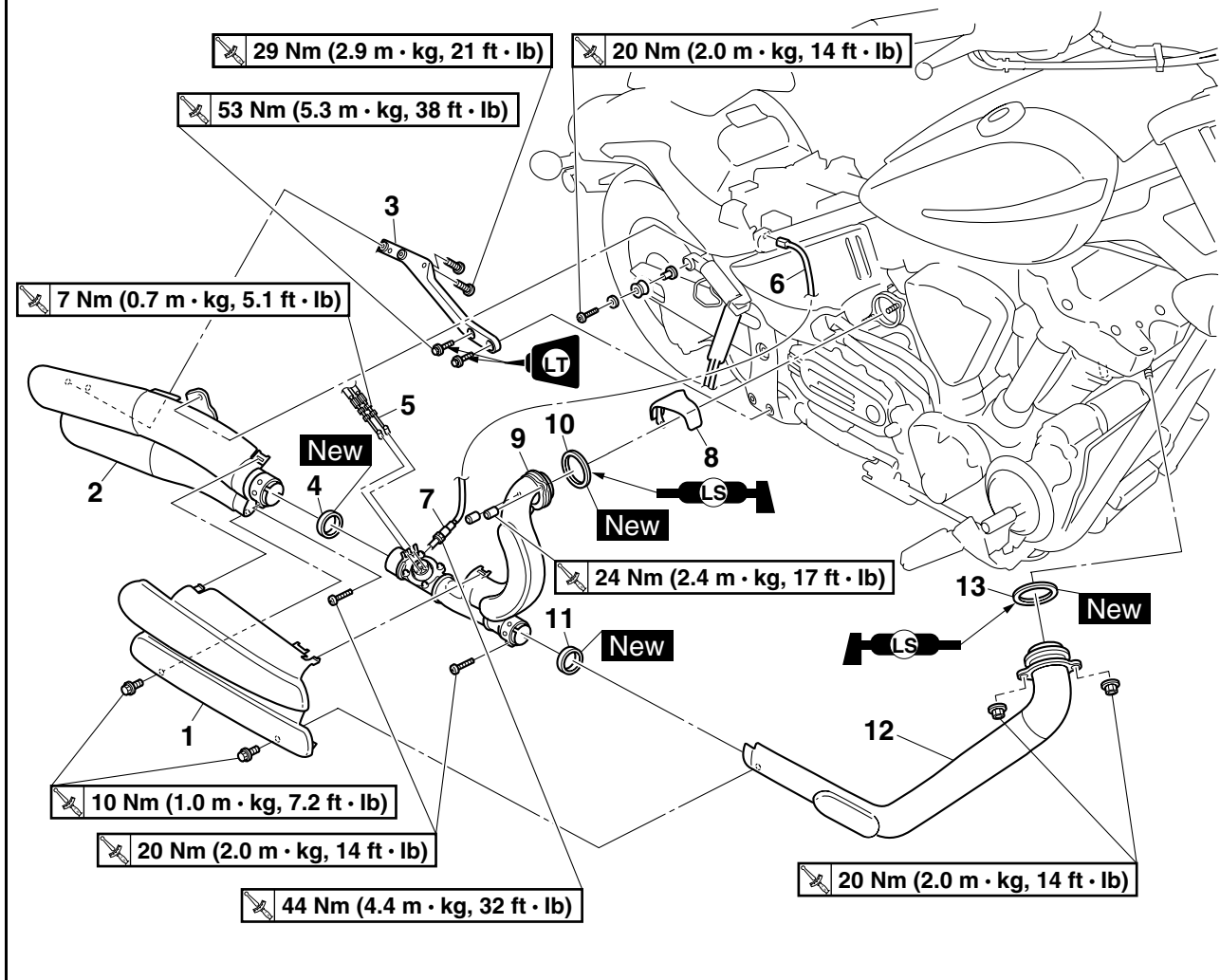

Order	Job/Parts to remove	Q'ty	Remarks
	Rider seat		Refer to "GENERAL CHASSIS" on page 4-1.
1	EXUP valve pulley cover	1	
2	Muffler	1	
3	Muffler bracket	1	
4	Gasket	1	
5	EXUP cable	2	Disconnect.
6	O ₂ sensor coupler	1	Disconnect.
7	O ₂ sensor	1	
8	Rear exhaust pipe cover	1	
9	Rear exhaust pipe	1	
10	Gasket	1	
11	Gasket	1	
12	Front exhaust pipe	1	
13	Gasket	1	
			For installation, reverse the removal procedure.

ENGINE REMOVAL

Removing the cylinder-#1 ignition coils and sidestand (for XV19S(C)/ XV19M(C)/ XV19CTS(C)/ XV19CTM(C))

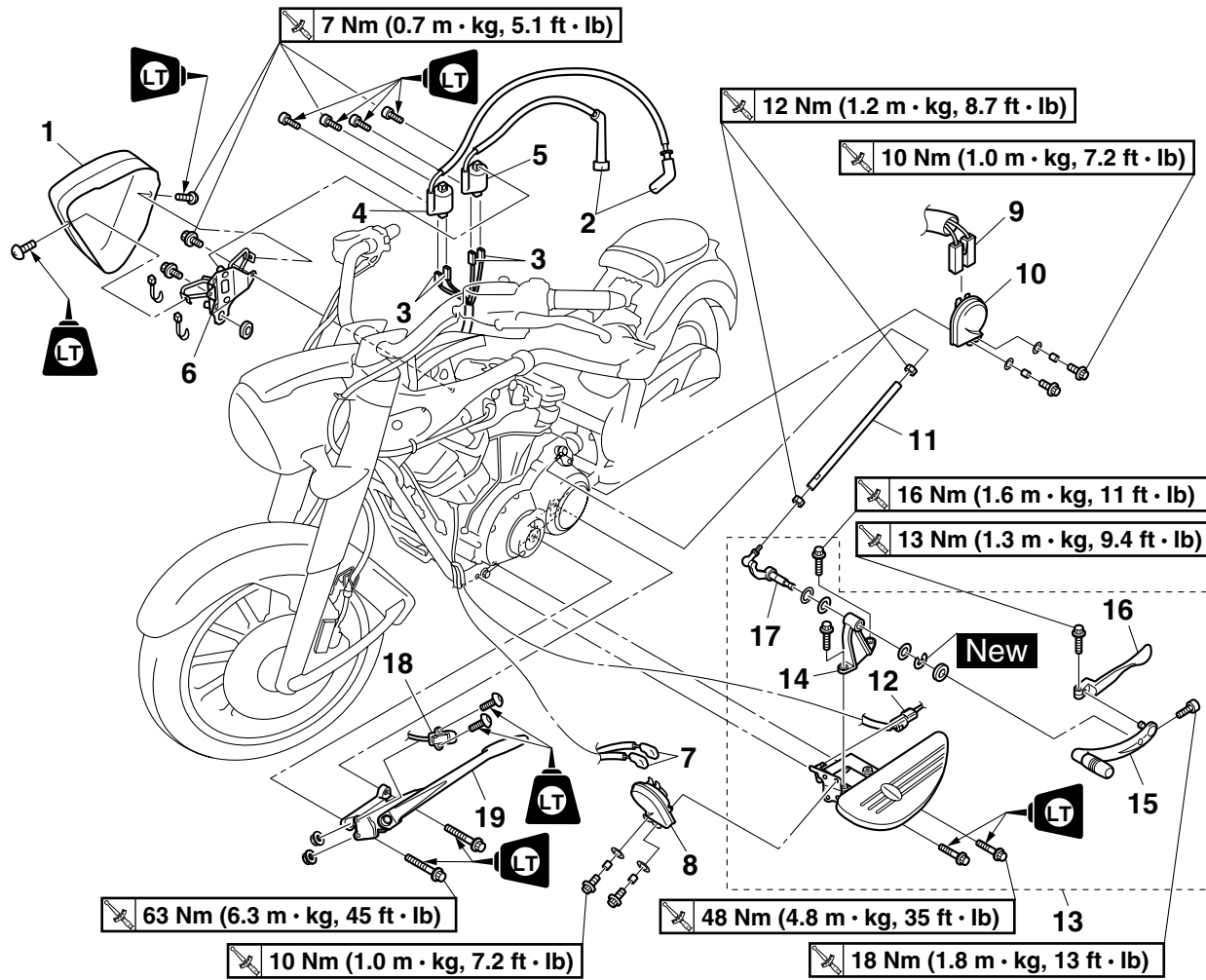

Order	Job/Parts to remove	Q'ty	Remarks
	Rider seat/Left side cover/Battery box/Air filter case		Refer to "GENERAL CHASSIS" on page 4-1.
	Fuel tank/Sub-fuel tank		Refer to "FUEL TANK" on page 6-1.
	Throttle body/Intake manifold/Pressure regulator bracket/Rollover valve/Canister		Refer to "THROTTLE BODIES" on page 6-7.
	Rear brake master cylinder bracket		Refer to "REAR BRAKE" on page 4-47.
	Drive pulley		Refer to "BELT DRIVE" on page 4-90.
	Engine oil		Drain. Refer to "CHANGING THE ENGINE OIL" on page 3-11.
	Transfer gear oil		Drain. Refer to "CHANGING THE TRANSFER GEAR OIL" on page 3-14.
	Starter motor		Refer to "ELECTRIC STARTER" on page 5-82.
1	Cylinder-#1 ignition coil cover	1	
2	Spark plug cap	2	
3	Ignition coil connector	4	Disconnect.
4	Cylinder-#1 left ignition coil	1	
5	Cylinder-#1 right ignition coil	1	

ENGINE REMOVAL

Removing the cylinder-#1 ignition coils and sidestand (for XV19S(C)/ XV19M(C)/ XV19CTS(C)/ XV19CTM(C))

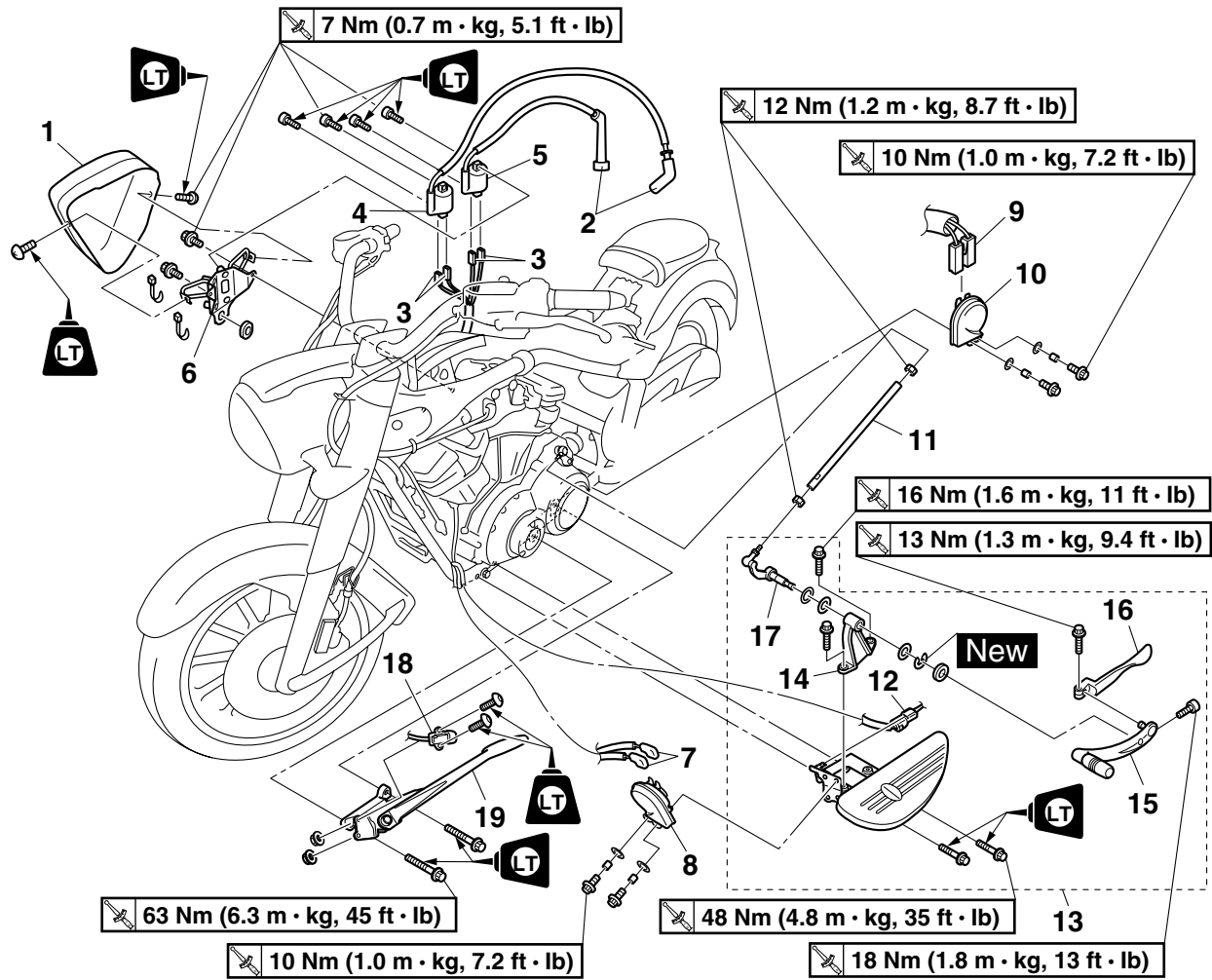

Order	Job/Parts to remove	Q'ty	Remarks
6	Cylinder-#1 ignition coil bracket	1	
7	Horn 1 connector	2	Except for California Disconnect.
8	Horn 1	1	Except for California
9	Horn 2 coupler	1	
10	Horn 2	1	
11	Shift rod	1	
12	Rear brake light switch coupler	1	
13	Left rider footrest assembly	1	
14	Shift pedal shaft bracket	1	
15	Shift pedal (toe side)	1	
16	Shift pedal (heel side)	1	
17	Shift pedal shaft	1	
18	Sidestand switch	1	
19	Sidestand	1	
			For installation, reverse the removal procedure.

ENGINE REMOVAL

Removing the right ignition coils and sidestand (for XV19CS(C)/ XV19C(C))

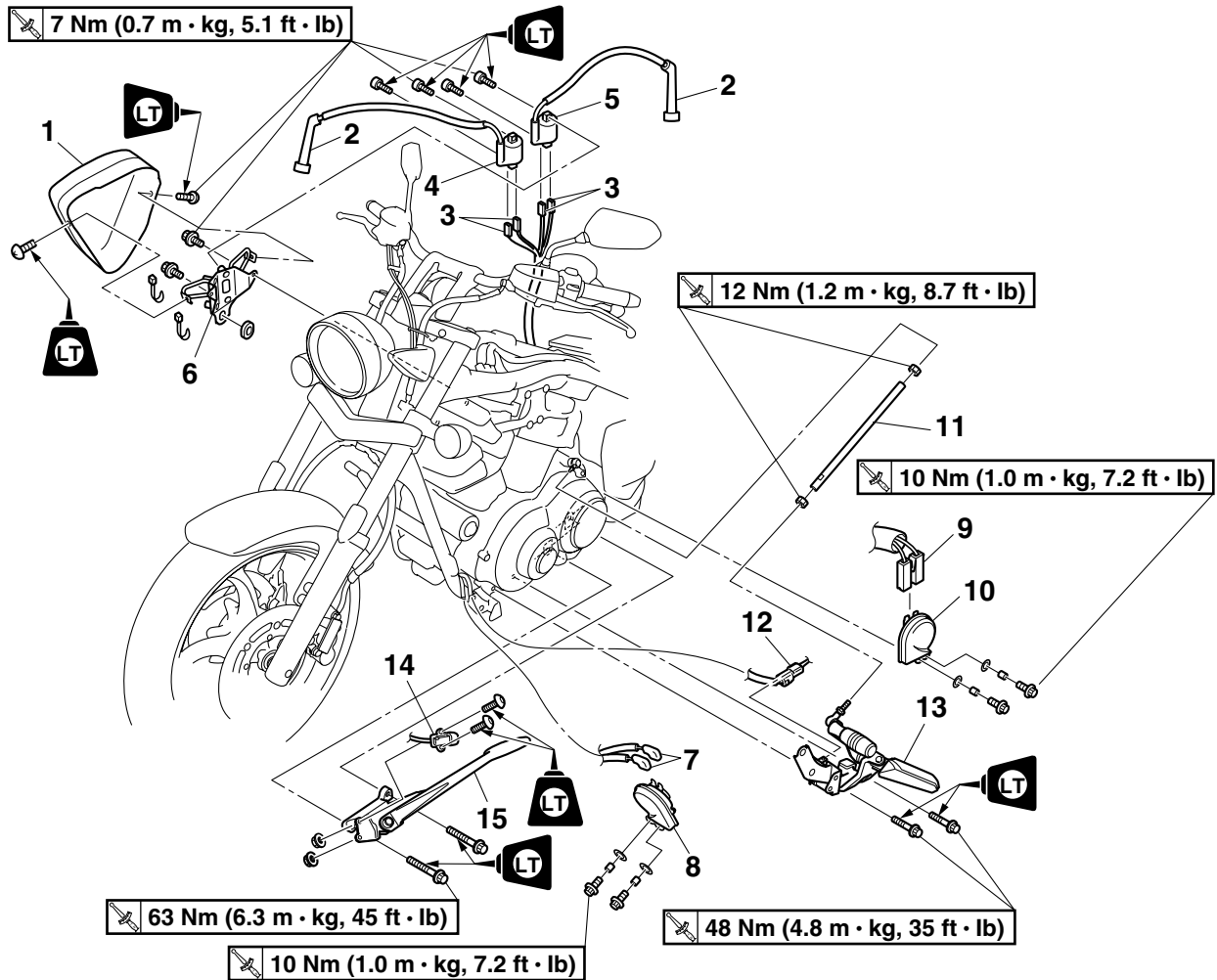

Order	Job/Parts to remove	Q'ty	Remarks
	Rider seat/Left side cover/Battery box/Air filter case		Refer to "GENERAL CHASSIS" on page 4-1.
	Fuel tank/Sub-fuel tank		Refer to "FUEL TANK" on page 6-1.
	Throttle body/Intake manifold/Pressure regulator bracket/Rollover valve/Canister		Refer to "THROTTLE BODIES" on page 6-7.
	Rear brake master cylinder bracket		Refer to "REAR BRAKE" on page 4-47.
	Drive pulley		Refer to "BELT DRIVE" on page 4-90.
	Engine oil		Drain. Refer to "CHANGING THE ENGINE OIL" on page 3-11.
	Transfer gear oil		Drain. Refer to "CHANGING THE TRANSFER GEAR OIL" on page 3-14.
	Starter motor		Refer to "ELECTRIC STARTER" on page 5-82.
1	Right ignition coil cover	1	
2	Spark plug cap	2	
3	Ignition coil connector	4	Disconnect.
4	Cylinder-#2 right ignition coil	1	
5	Cylinder-#1 right ignition coil	1	

ENGINE REMOVAL

Removing the right ignition coils and sidestand (for XV19CS(C)/ XV19C(C))

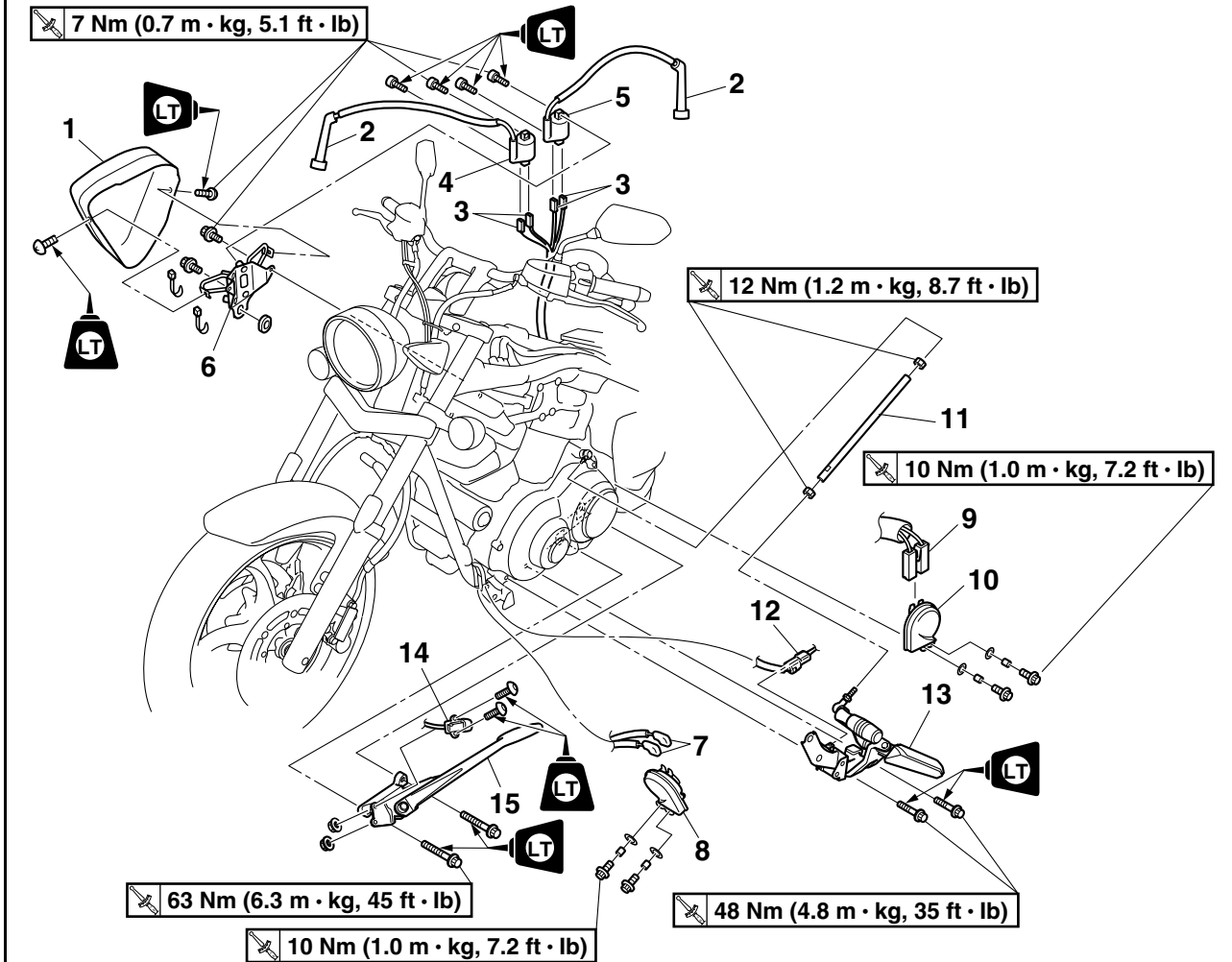

Order	Job/Parts to remove	Q'ty	Remarks
6	Right ignition coil bracket	1	
7	Horn 1 connector	2	Except for California Disconnect.
8	Horn 1	1	Except for California
9	Horn 2 coupler	1	
10	Horn 2	1	
11	Shift rod	1	
12	Rear brake light switch coupler	1	
13	Shift pedal assembly	1	
14	Sidestand switch	1	
15	Sidestand	1	
			For installation, reverse the removal procedure.

ET1D71029

INSTALLING THE SHIFT PEDAL ASSEMBLY

1. Assemble: (for XV19S(C)/ XV19M(C)/ XV19CTS(C)/ XV19CTM(C))
 - Shift pedal (heel side) “1”
 - Shift pedal (toe side) “2”



Shift pedal (heel side) bolt
13 Nm (1.3 m·kg, 9.4 ft·lb)

NOTE:

Align the mark “a” on the pin on the toe side with the mark “b” on the heel side.

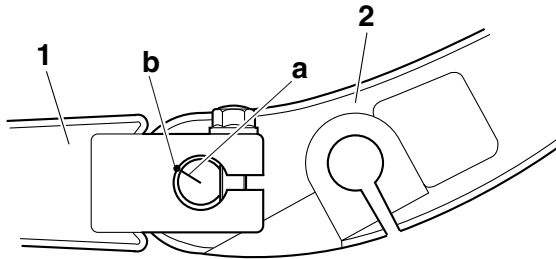

2. Install: (for XV19S(C)/ XV19M(C)/ XV19CTS(C)/ XV19CTM(C))
 - Shift pedal assembly “1”

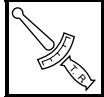

Shift pedal bolt
18 Nm (1.8 m·kg, 13 ft·lb)

NOTE:

Align the mark “a” on the shift pedal shaft with the slot in the shift pedal.

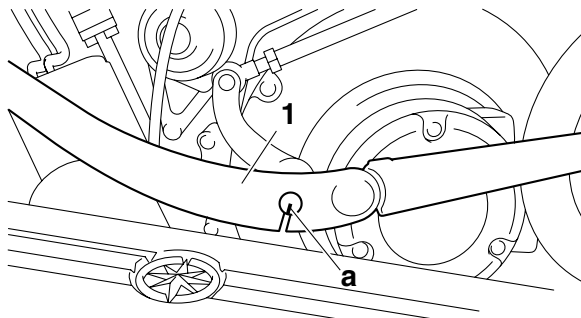

3. Adjust: (for XV19CS(C)/ XV19C(C))
 - Shift rod lengthRefer to “ADJUSTING THE SHIFT PEDAL” on page 3-25.

Removing the oil cooler and oil filter bracket

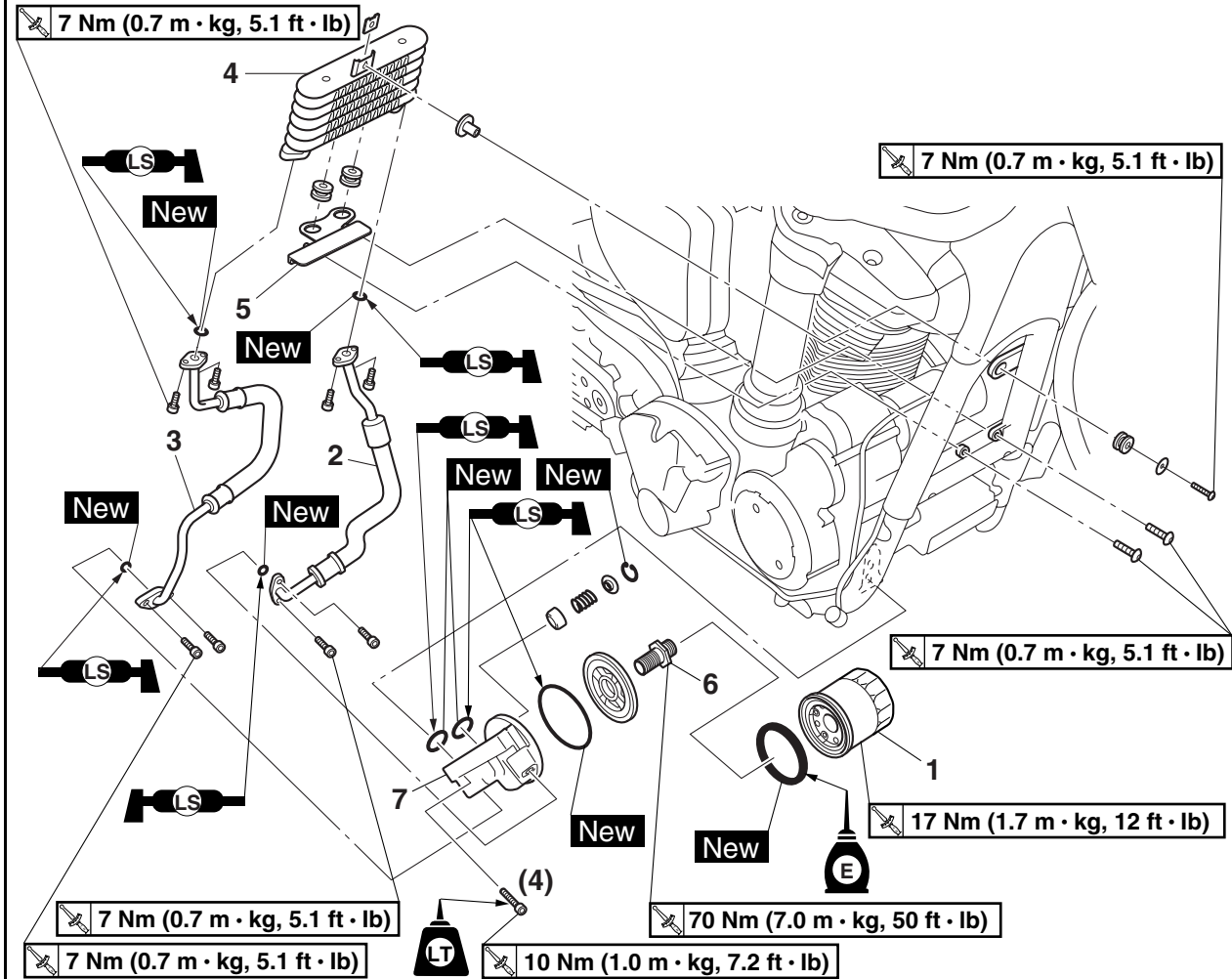

Order	Job/Parts to remove	Q'ty	Remarks
1	Oil filter cartridge	1	
2	Oil cooler outlet hose	1	For XV19S(C)/ XV19M(C)/ XV19CTS(C)/ XV19CTM(C)
3	Oil cooler inlet hose	1	For XV19S(C)/ XV19M(C)/ XV19CTS(C)/ XV19CTM(C)
4	Oil cooler	1	For XV19S(C)/ XV19M(C)/ XV19CTS(C)/ XV19CTM(C)
5	Oil cooler bracket	1	For XV19S(C)/ XV19M(C)/ XV19CTS(C)/ XV19CTM(C)
6	Oil filter bolt	1	
7	Oil filter bracket	1	
			For installation, reverse the removal procedure.

ET1D71028

CHECKING THE OIL COOLER (for XV19S(C)/ XV19M(C)/ XV19CTS(C)/ XV19CTM(C))

1. Check:

- Oil cooler fins
Obstruction → Clean.
Apply compressed air to the rear of the oil cooler.
- Damage → Repair or replace.

NOTE:

Straighten any flattened fins with a thin, flathead screwdriver.

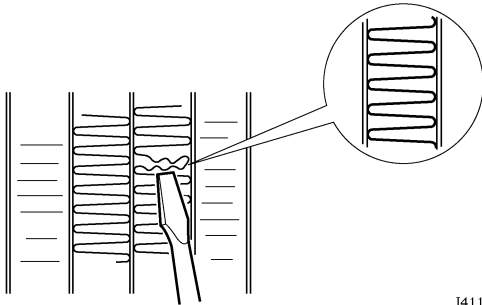

I4110401

2. Check:

- Oil cooler inlet hose
- Oil cooler outlet hose
Cracks/damage → Replace.

ENGINE REMOVAL

Disconnecting the leads

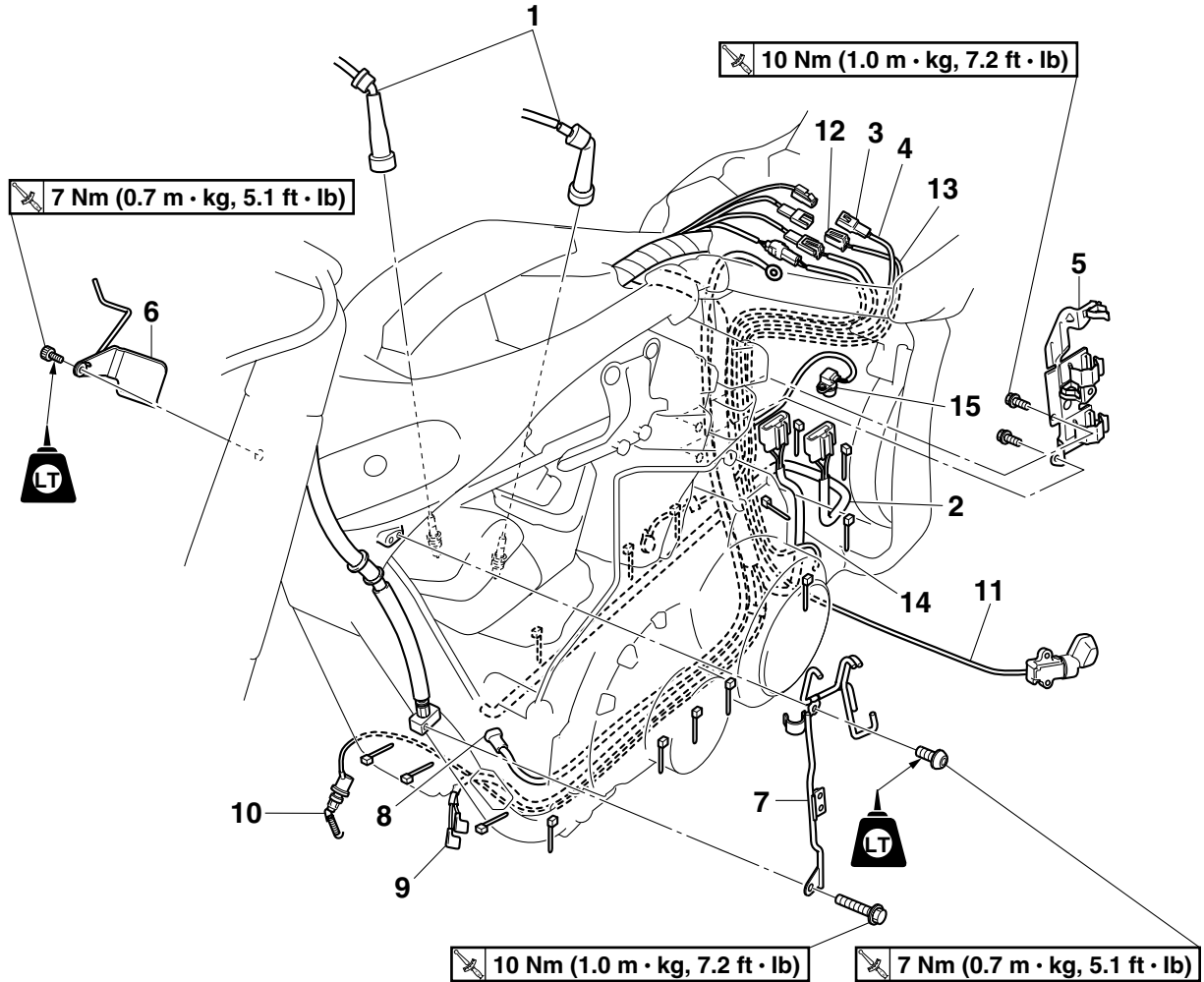

Order	Job/Parts to remove	Q'ty	Remarks
	Drive pulley case		Refer to "TRANSFER GEAR CASE" on page 5-86.
1	Spark plug cap	2	
2	Stator coil lead	1	
3	Neutral switch coupler	1	Disconnect.
4	Neutral switch lead	1	
5	Lead holder bracket	1	
6	Wire harness guide	1	
7	Throttle cable guide	1	
8	Starter motor lead	1	
9	Horn 2 lead	1	
10	Rear brake light switch lead	1	
11	Sidestand switch lead	1	
12	Crankshaft position sensor coupler	1	Disconnect.
13	Crankshaft position sensor lead	1	
14	Rectifier/regulator lead	1	

ENGINE REMOVAL

Disconnecting the leads

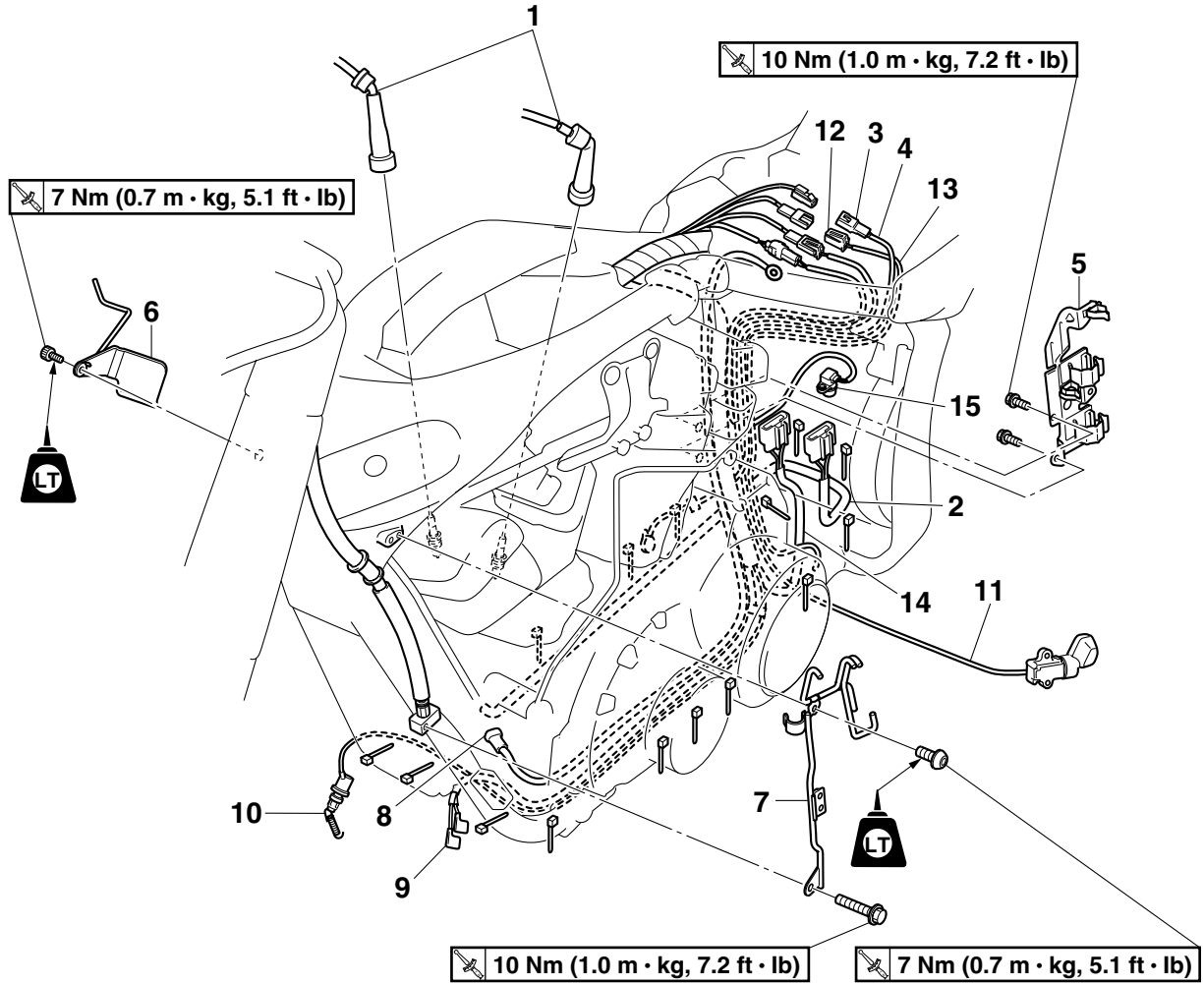

Order	Job/Parts to remove	Q'ty	Remarks
15	Speed sensor lead	1	
			For installation, reverse the removal procedure.

ENGINE REMOVAL

Removing the engine

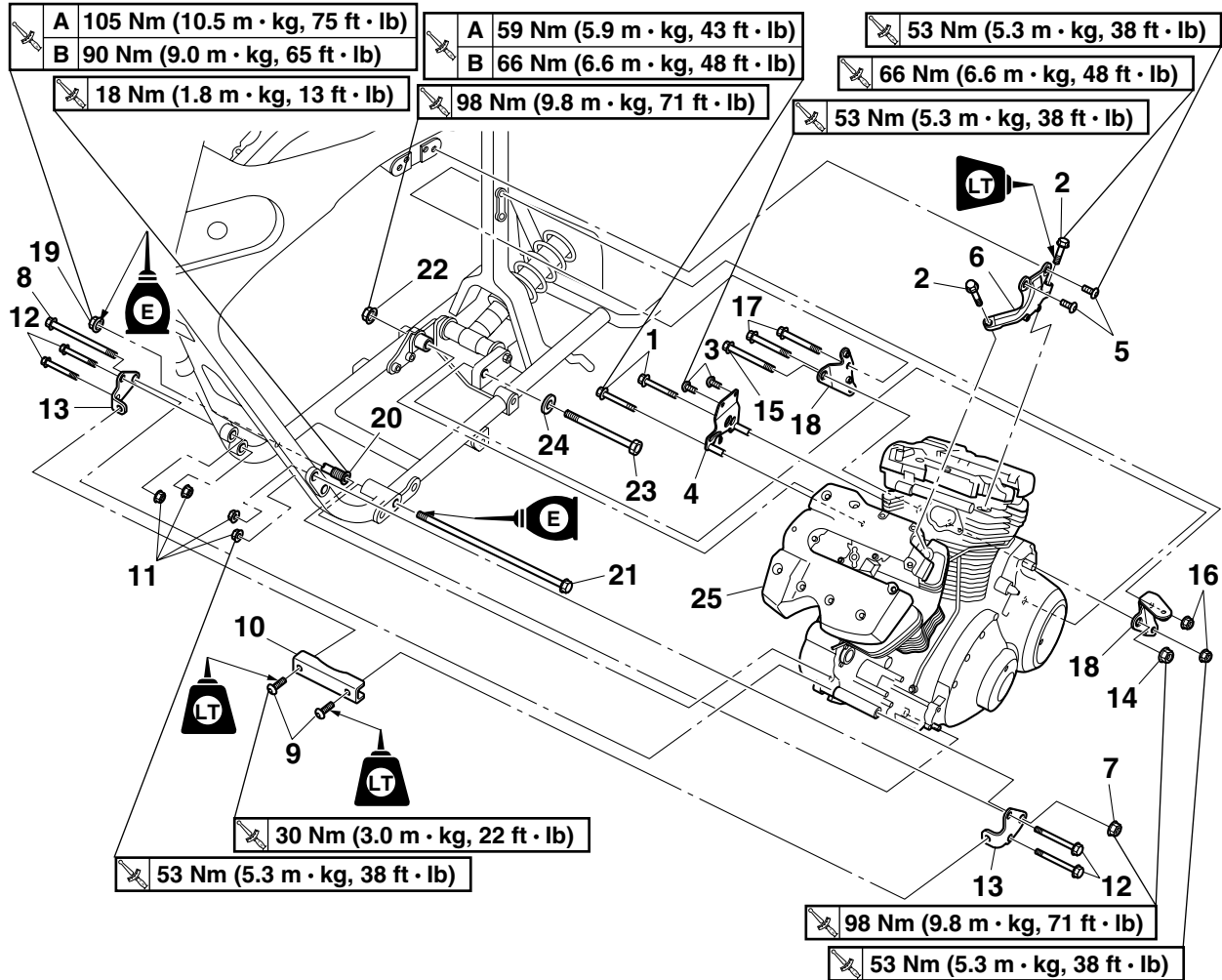

Order	Job/Parts to remove	Q'ty	Remarks
			NOTE: _____ Place a suitable stand under the frame and engine.
	Transfer gear case		Refer to "TRANSFER GEAR CASE" on page 5-86.
1	Engine mounting bolt (right upper side)	2	
2	Engine mounting bolt (left upper side)	2	
3	Engine bracket bolt (right upper side)	2	
4	Engine bracket (right upper side)	1	
5	Engine bracket bolt (left upper side)	2	
6	Engine bracket (left upper side)	1	
7	Engine mounting nut (front upper side)	1	
8	Engine mounting bolt (front upper side)	1	
9	Engine cross-member bracket bolt	2	
10	Engine cross-member bracket	1	
11	Engine bracket nut (front upper side)	4	
12	Engine bracket bolt (front upper side)	4	
13	Engine bracket (front upper side)	2	

ENGINE REMOVAL

Removing the engine

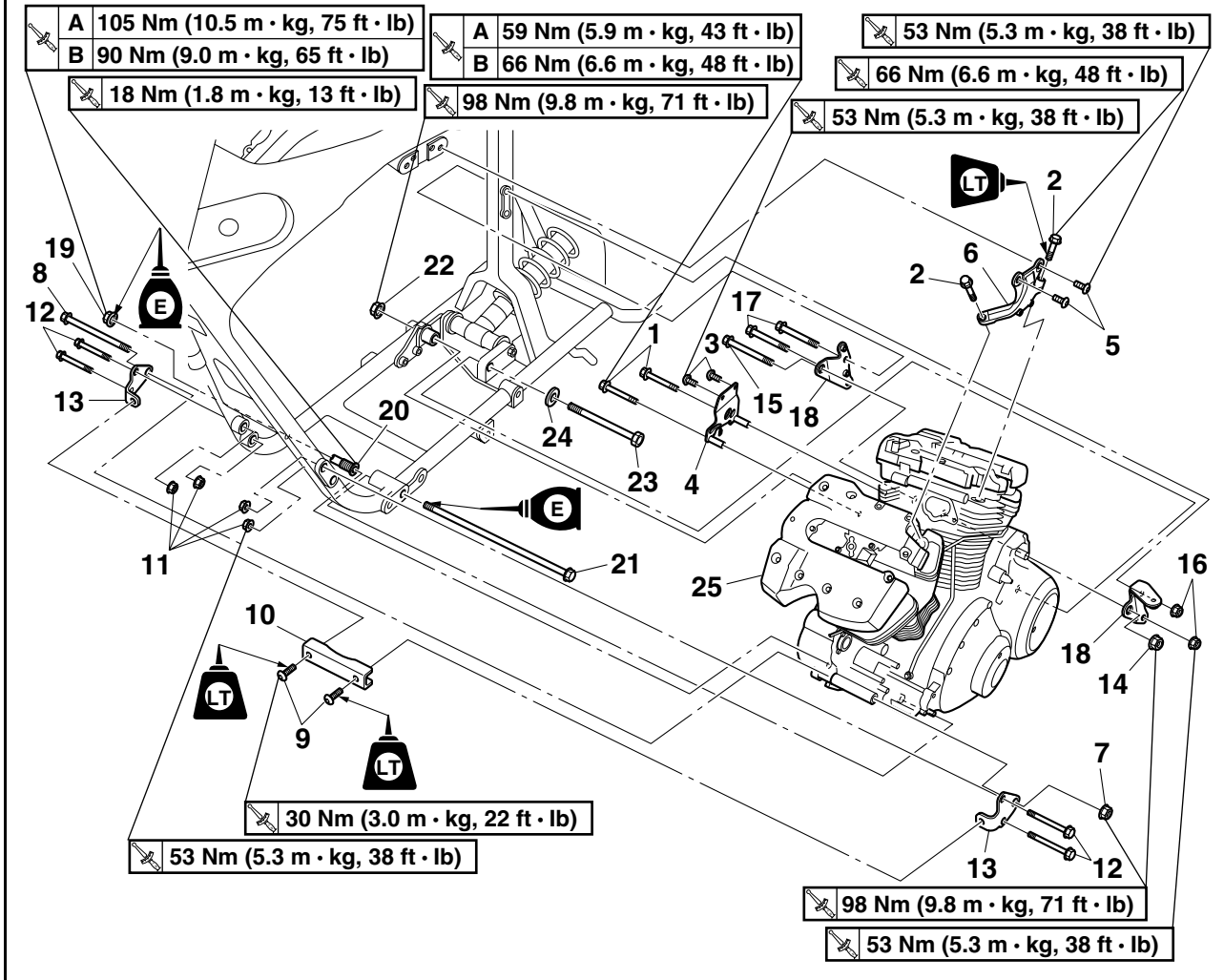

Order	Job/Parts to remove	Q'ty	Remarks
14	Engine mounting nut (rear upper side)	1	
15	Engine mounting bolt (rear upper side)	1	
16	Engine bracket nut (rear upper side)	2	
17	Engine bracket bolt (rear upper side)	2	
18	Engine bracket (rear upper side)	2	
19	Engine mounting nut (front lower side)	1	
20	Spacer bolt	1	Loosen.
21	Engine mounting bolt (front lower side)	1	
22	Engine mounting nut (rear lower side)	1	
23	Engine mounting bolt (rear lower side)	1	
24	Washer	1	
25	Engine	1	
			For installation, reverse the removal procedure.

A: For XV19S(C)/ XV19M(C)/ XV19CTS(C)/ XV19CTM(C)
 B: For XV19CS(C)/ XV19C(C)

ET1D71019

REMOVING THE ENGINE

1. Loosen:

- Spacer bolt "1"

NOTE:

Loosen the spacer bolt with the pivot shaft wrench "1".



Pivot shaft wrench
90890-01485
Frame mount insert wrench
YM-01485

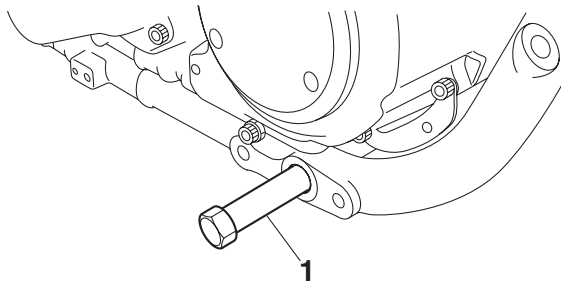

EAS23720

INSTALLING THE ENGINE

1. Install:

- Spacer bolt "1"
- Engine "2"
- Washer "3"
- Engine mounting bolt (rear lower side) "4"
- Engine mounting nut (rear lower side) "5"
- Engine mounting bolt (front lower side) "6"
- Engine mounting nut (front lower side) "7"
- Engine brackets (rear upper side) "8"
- Engine bracket bolts (rear upper side) "9"
- Engine bracket nuts (rear upper side) "10"
- Engine mounting bolt (rear upper side) "11"
- Engine mounting nut (rear upper side) "12"
- Engine bracket (left upper side) "13"
- Engine mounting bolts (left upper side) "14"
- Engine bracket bolts (left upper side) "15"
- Engine bracket (right upper side) "16"
- Engine mounting bolts (right upper side) "17"
- Engine bracket bolts (right upper side) "18"

NOTE:

- Lubricate the engine mounting bolt (front lower side) threads and nut with engine oil.
- Apply locking agent (LOCTITE®) to the threads of the engine mounting bolts (left upper side).
- Do not fully tighten the bolts and nuts.

2. Remove:

- Engine mounting nut (front lower side) "7"

3. Tighten:

- Spacer bolt "1"



Spacer bolt
18 Nm (1.8 m·kg, 13 ft·lb)

NOTE:

- Tighten the spacer bolt "1" to specification with a pivot shaft wrench.
- When tightened, the spacer bolt should be flat against the engine surface.



Pivot shaft wrench
90890-01485
Frame mount insert wrench
YM-01485

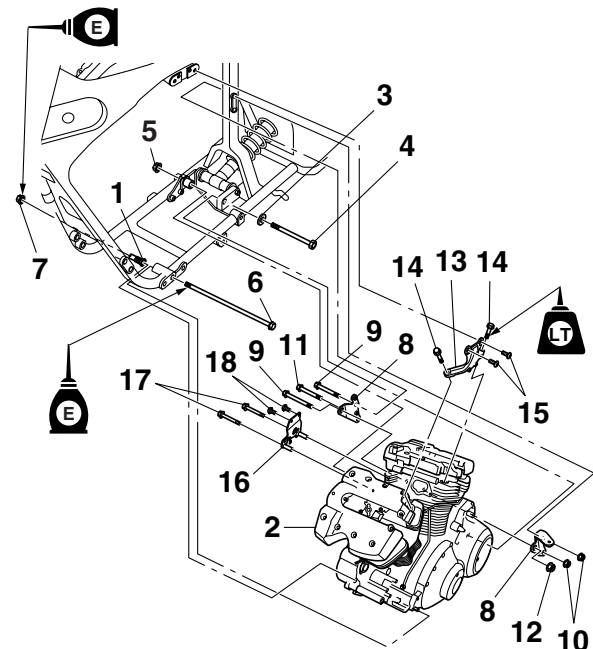

4. Tighten:

- Engine mounting nut (rear lower side) "5"
- Engine mounting nut (front lower side) "7"
- Engine bracket nuts (rear upper side) "10"
- Engine mounting nut (rear upper side) "12"
- Engine mounting bolts (left upper side) "14"
- Engine bracket bolts (left upper side) "15"
- Engine mounting bolts (right upper side) "17"
- Engine bracket bolts (right upper side) "18"



- Engine mounting nut (rear lower side)**
98 Nm (9.8 m·kg, 71 ft·lb)
- Engine mounting nut (front lower side)**
XV19S(C)/ XV19M(C)/
XV19CTS(C)/ XV19CTM(C):
105 Nm (10.5 m·kg, 75 ft·lb)
- XV19CS(C)/ XV19C(C):**
90 Nm (9.0 m·kg, 65 ft·lb)
- Engine bracket nut (rear upper side)**
53 Nm (5.3 m·kg, 38 ft·lb)
- Engine mounting nut (rear upper side)**
98 Nm (9.8 m·kg, 71 ft·lb)
- Engine mounting bolt (left upper side)**
66 Nm (6.6 m·kg, 48 ft·lb)
- LOCTITE®**
- Engine mounting bolt (right upper side)**
XV19S(C)/ XV19M(C)/
XV19CTS(C)/ XV19CTM(C):
59 Nm (5.9 m·kg, 43 ft·lb)
- XV19CS(C)/ XV19C(C):**
66 Nm (6.6 m·kg, 48 ft·lb)
- Engine bracket bolt (left upper side)**
53 Nm (5.3 m·kg, 38 ft·lb)
- Engine bracket bolt (right upper side)**
53 Nm (5.3 m·kg, 38 ft·lb)

NOTE:

To install and route the leads, refer to “CABLE ROUTING (for XV19S(C)/ XV19M(C)/ XV19CTS(C)/ XV19CTM(C))” on page 2-51 and “CABLE ROUTING (for XV19CS(C)/ XV19C(C))” on page 2-67.

- Refer to “ENGINE REMOVAL” on page 5-1.
- 7. Install:
 - Transfer gear case
 - Drive pulley case
 Refer to “TRANSFER GEAR CASE” on page 5-86.
- 8. Install:
 - Drive pulley
 - Transfer gear case bracket
 Refer to “BELT DRIVE” on page 4-90.
- 9. Tighten:
 - Engine bracket nuts (front upper side) “3”
 - Engine cross-member bracket bolts “5”
 - Engine mounting nut (front upper side) “7”



- Engine bracket nut (front upper side)**
53 Nm (5.3 m·kg, 38 ft·lb)
- Engine cross-member bracket bolt**
30 Nm (3.0 m·kg, 22 ft·lb)
- LOCTITE®**
- Engine mounting nut (front upper side)**
98 Nm (9.8 m·kg, 71 ft·lb)

- 5. Install:
 - Engine brackets (front upper side) “1”
 - Engine bracket bolts (front upper side) “2”
 - Engine bracket nuts (front upper side) “3”
 - Engine cross-member bracket “4”
 - Engine cross-member bracket bolts “5”
 - Engine mounting bolt (front upper side) “6”
 - Engine mounting nut (front upper side) “7”

NOTE:

Do not fully tighten the bolts and nuts.

- 6. Install:
 - Lead holder bracket
 - Lead
(removed during engine removal)

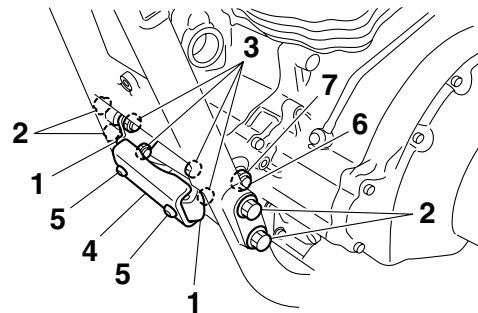

EAS23750

CAMSHAFTS

Removing the camshaft sprocket cover

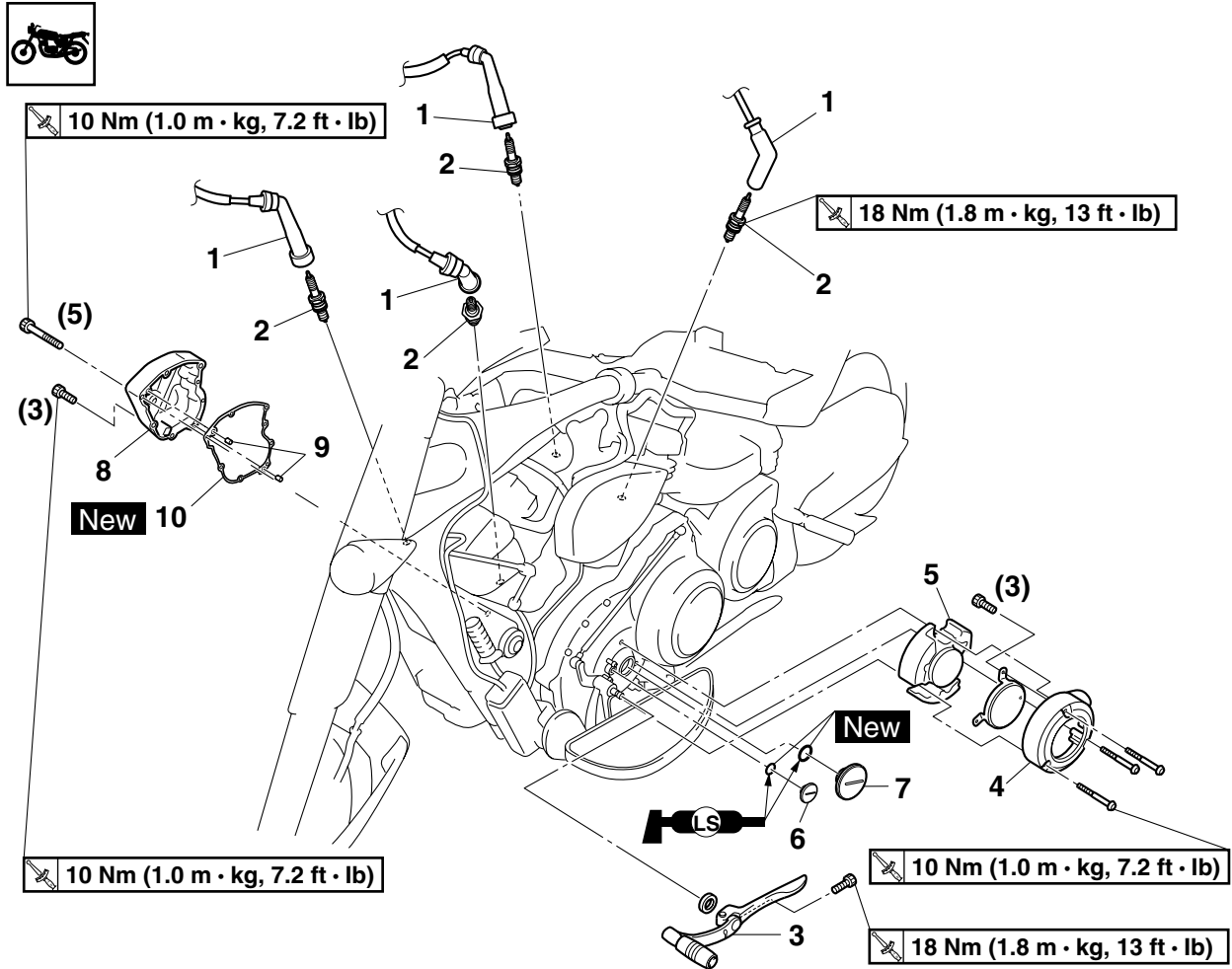

Order	Job/Parts to remove	Q'ty	Remarks
	Fuel tank		Refer to "FUEL TANK" on page 6-1.
	Air filter case		Refer to "GENERAL CHASSIS" on page 4-1.
	Muffler/Exhaust pipes		Refer to "ENGINE REMOVAL" on page 5-1.
1	Spark plug cap	4	Disconnect.
2	Spark plug	4	
3	Shift pedal assembly	1	For XV19S(C)/ XV19M(C)/ XV19CTS(C)/ XV19CTM(C)
4	Damper cover	1	
5	Damper	1	
6	Timing mark accessing screw	1	
7	Crankshaft end screw	1	
8	Camshaft sprocket cover	1	
9	Dowel pin	2	
10	Camshaft sprocket cover gasket	1	
			For installation, reverse the removal procedure.

Removing the cylinder head covers

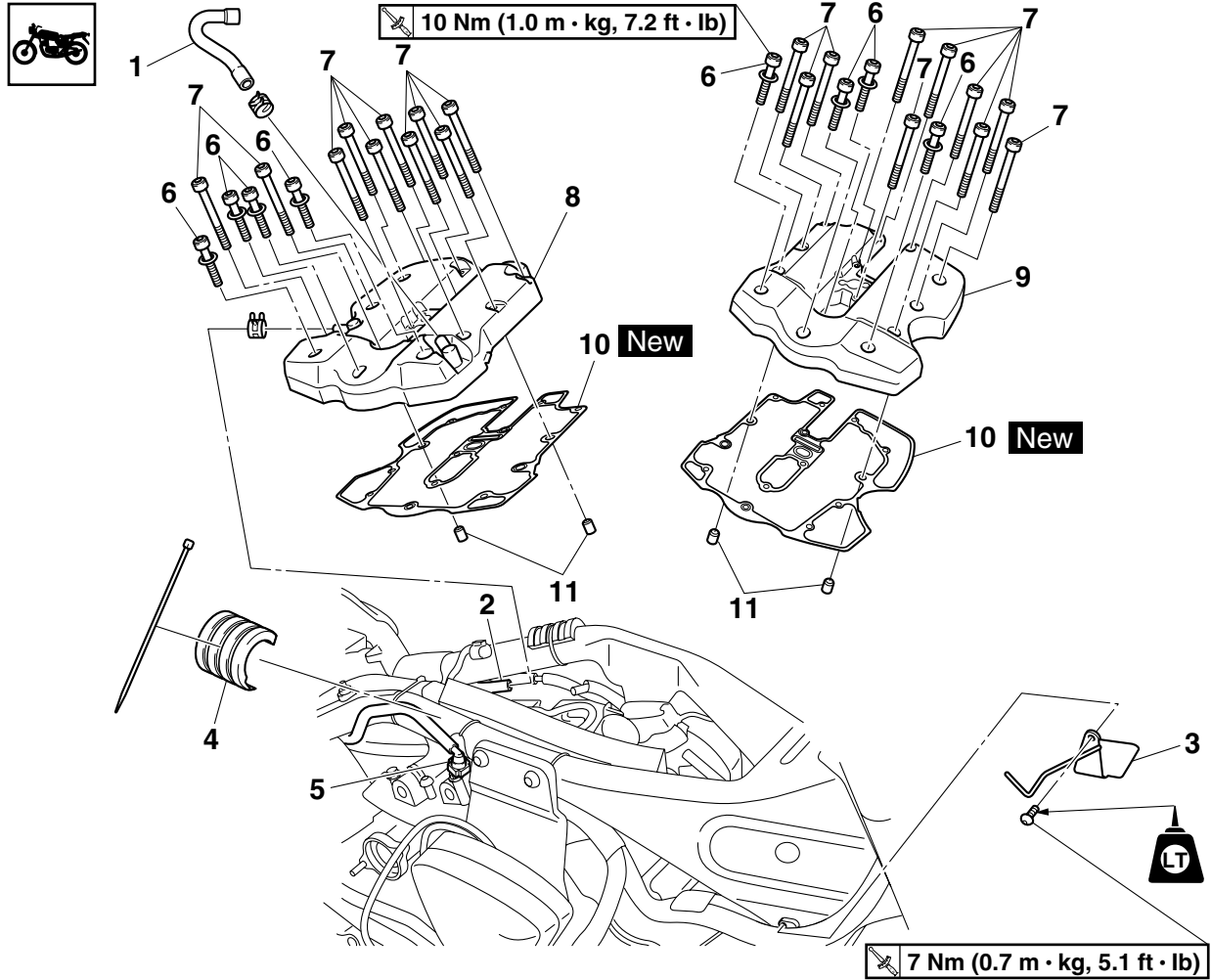

Order	Job/Parts to remove	Q'ty	Remarks
1	Cylinder head breather hose	1	
2	Oil tank breather hose	1	Disconnect.
3	Wire harness guide	1	
4	Fuel tank damper	1	
5	Fuel outlet hose	1	Disconnect.
6	Cylinder head cover bolt	8	l = 40 mm (1.57 in)
7	Cylinder head cover bolt	20	l = 60 mm (2.36 in)
8	Rear cylinder head cover	1	
9	Front cylinder head cover	1	
10	Cylinder head cover gasket	2	
11	Dowel pin	4	
			For installation, reverse the removal procedure.

Removing the push rods and rocker arms

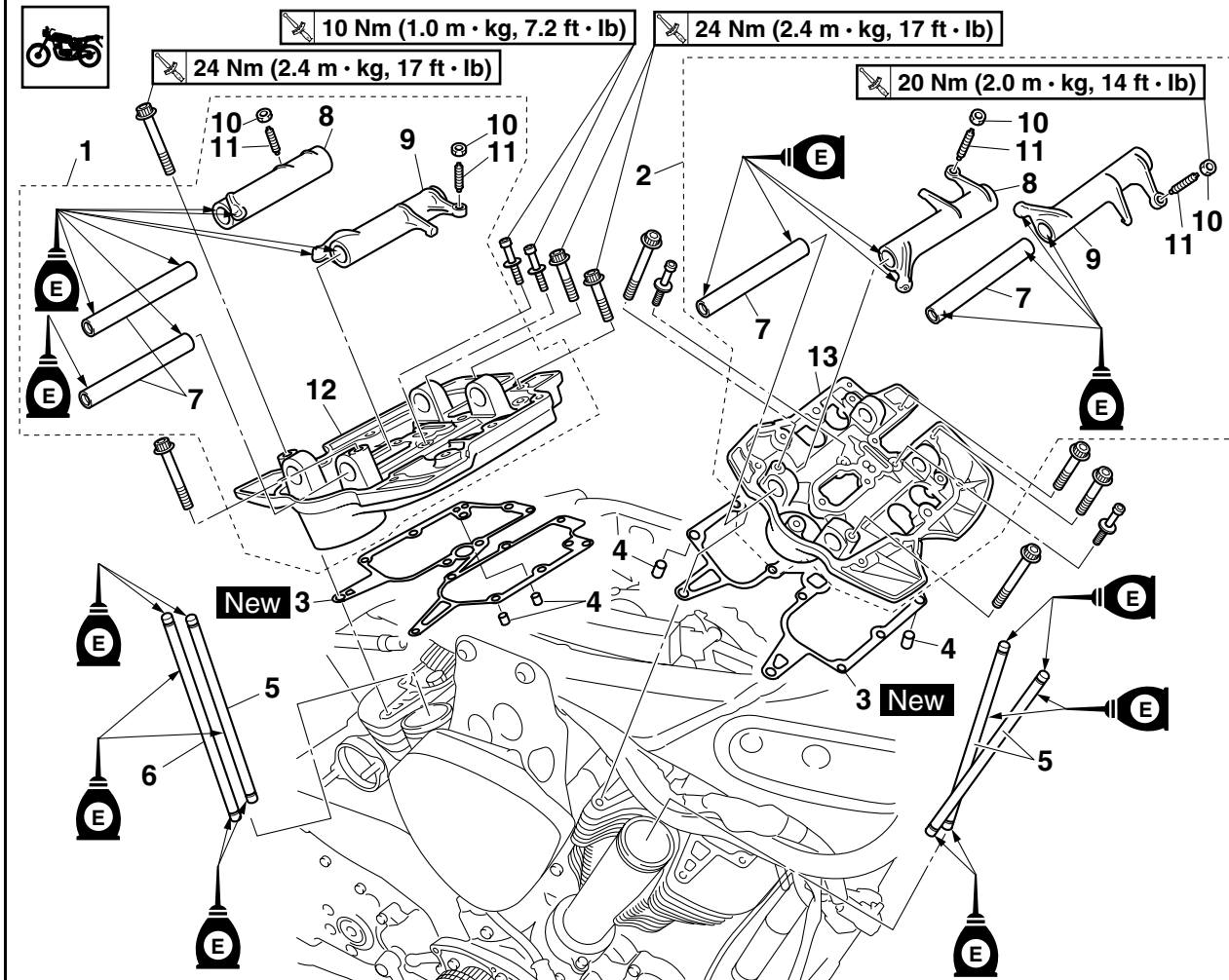

Order	Job/Parts to remove	Q'ty	Remarks
1	Rear rocker arm base assembly	1	
2	Front rocker arm base assembly	1	
3	Rocker arm base gasket	2	
4	Dowel pin	4	
5	Pull rod 1	3	l = 286.5 mm (11.280 in) pink painting
6	Pull rod 2	1	l = 288.5 mm (11.358 in) sky blue painting
7	Rocker arm shaft	4	
8	Rocker arm 1	2	
9	Rocker arm 2	2	
10	Locknut	4	
11	Adjusting screw	4	
12	Rear rocker arm base	1	
13	Front rocker arm base	1	
			For installation, reverse the removal procedure.

Removing the valve lifters

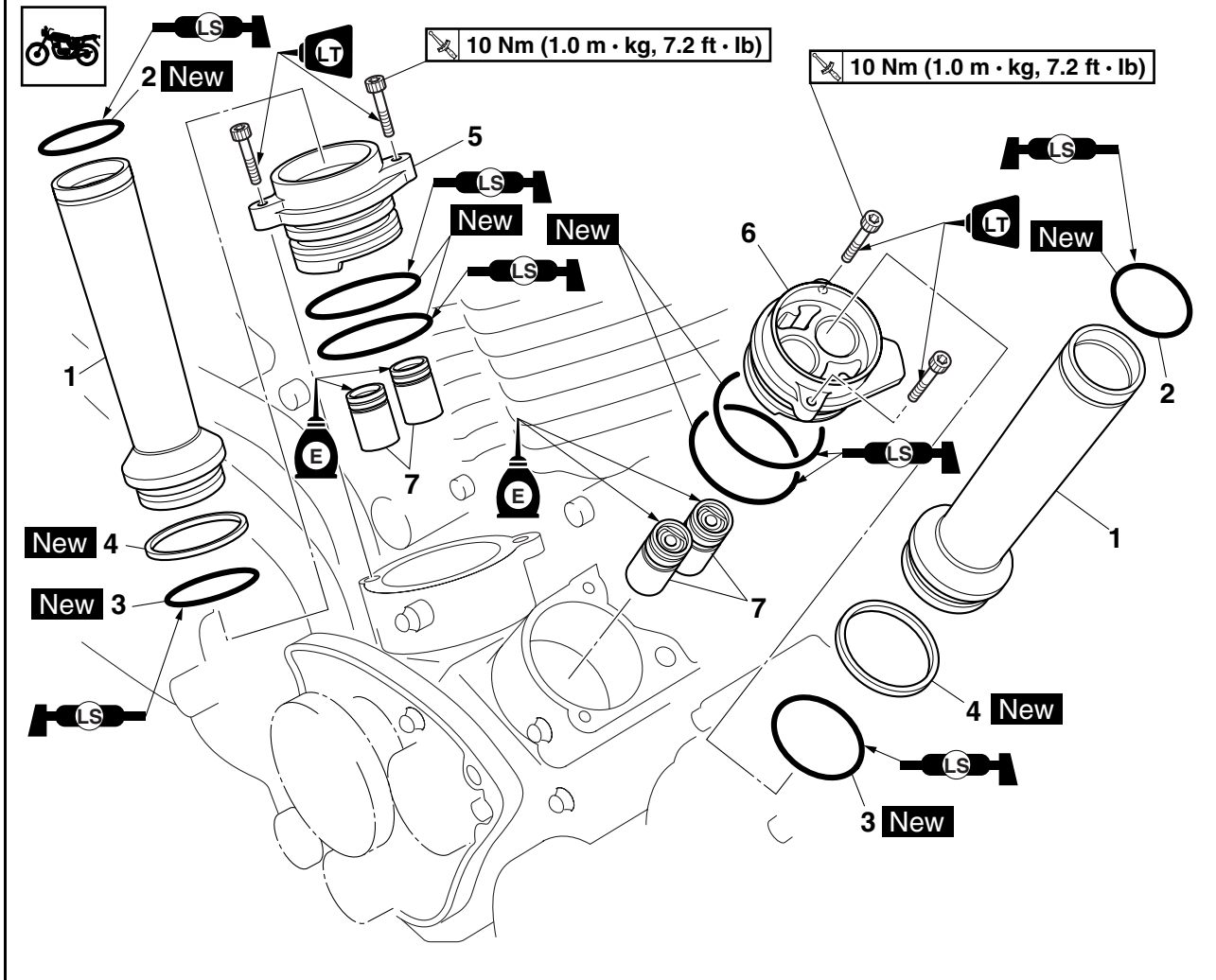

Order	Job/Parts to remove	Q'ty	Remarks
	Front cylinder		Refer to "CYLINDERS AND PISTONS" on page 5-48.
1	Push rod cover	2	
2	O-ring	2	
3	O-ring	2	
4	Seal	2	
5	Rear valve lifter case	1	
6	Front valve lifter case	1	
7	Valve lifter	4	
			For installation, reverse the removal procedure.

Removing the camshafts and right balancer

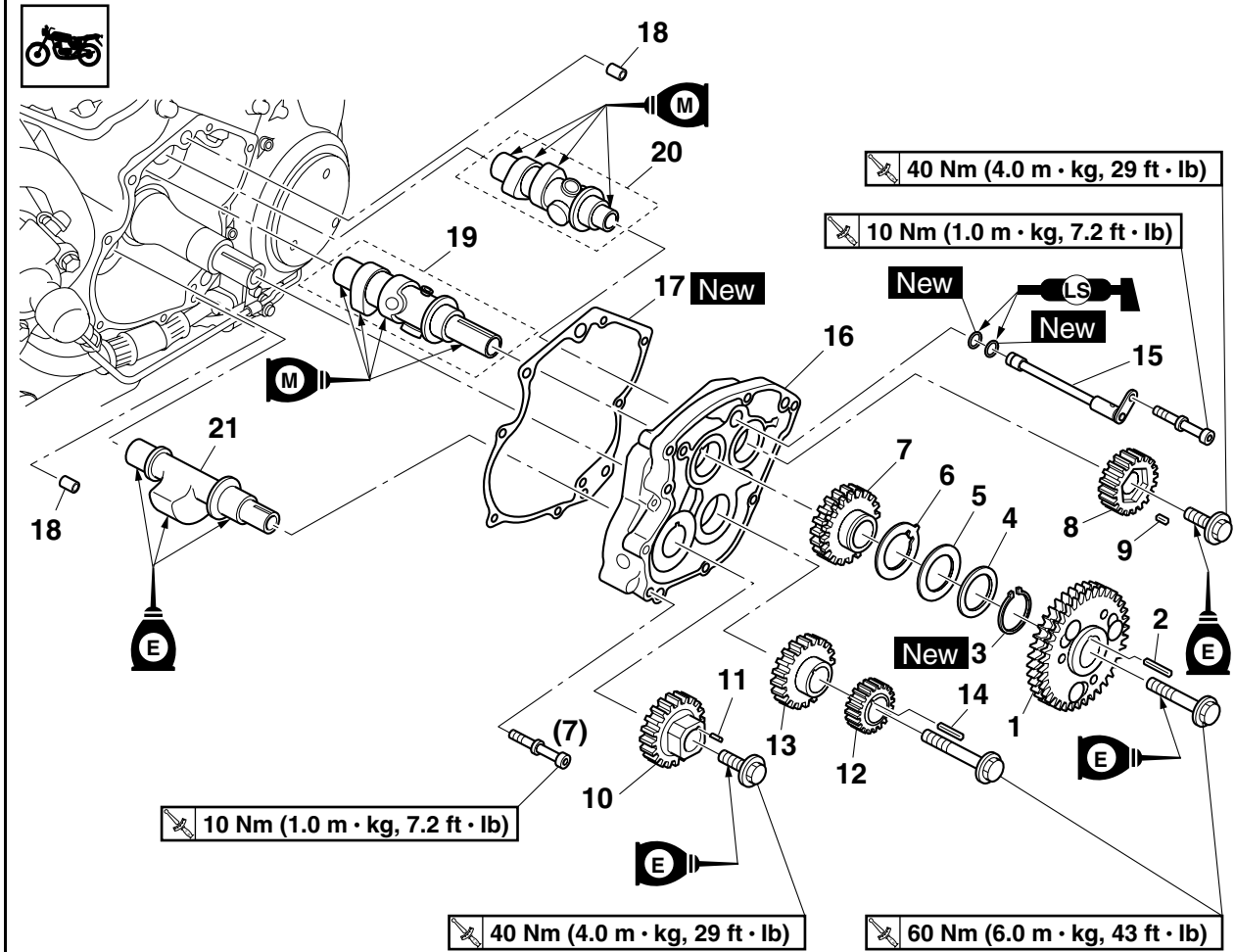

Order	Job/Parts to remove	Q'ty	Remarks
1	Camshaft driven gear	1	
2	Straight key	1	
3	Circlip	1	
4	Washer	1	
5	Conical spring washer	1	
6	Washer	1	
7	Rear cylinder camshaft gear	1	
8	Front cylinder camshaft gear	1	
9	Straight key	1	
10	Right balancer driven gear	1	
11	Straight key	1	
12	Camshaft drive gear	1	
13	Right balancer drive gear	1	
14	Straight key	1	
15	Oil delivery pipe 1	1	
16	Camshaft cover	1	
17	Camshaft cover gasket	1	

Removing the camshafts and right balancer

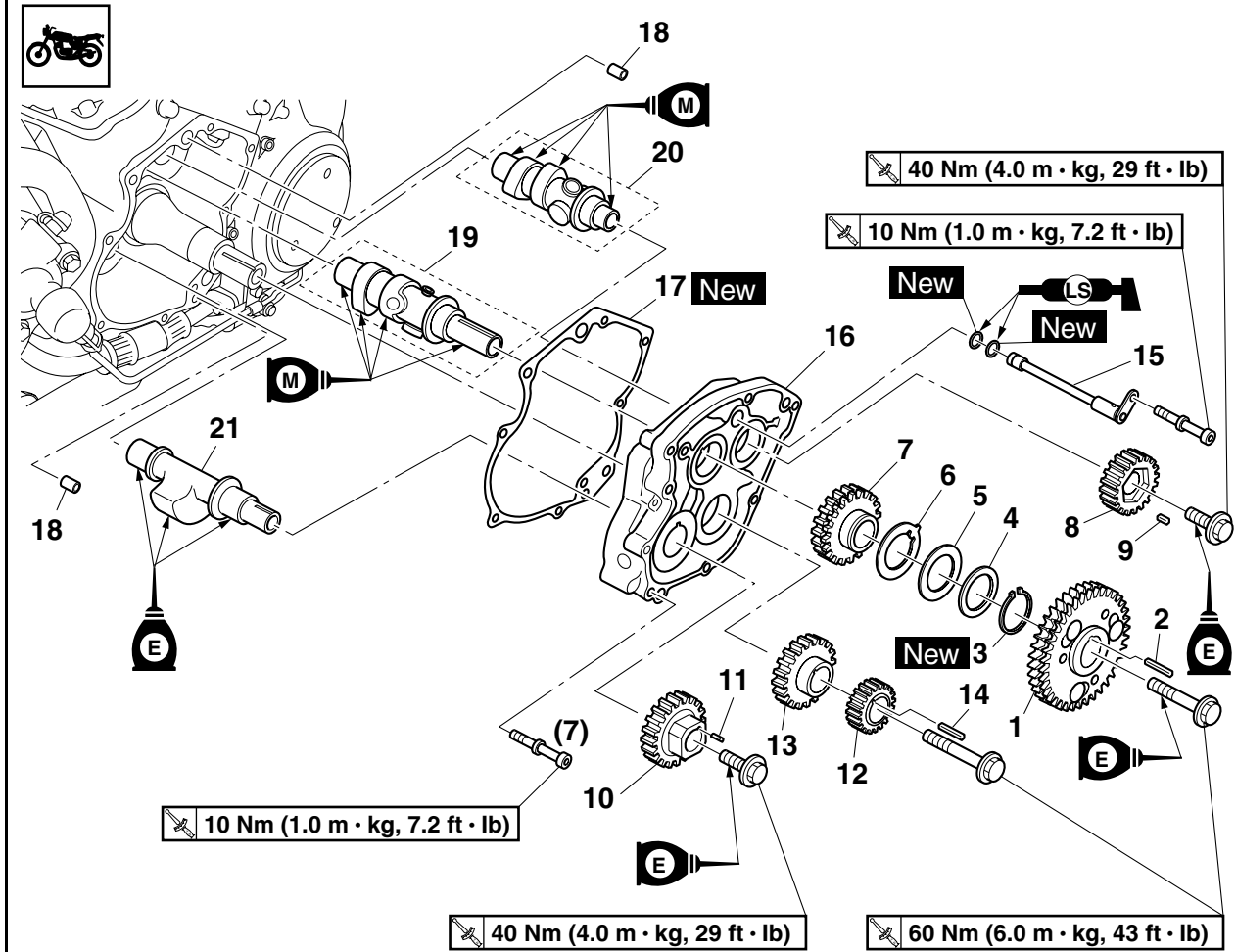

Order	Job/Parts to remove	Q'ty	Remarks
18	Dowel pin	2	
19	Rear cylinder camshaft	1	
20	Front cylinder camshaft	1	
21	Right balancer	1	
			For installation, reverse the removal procedure.

Disassembling the camshafts

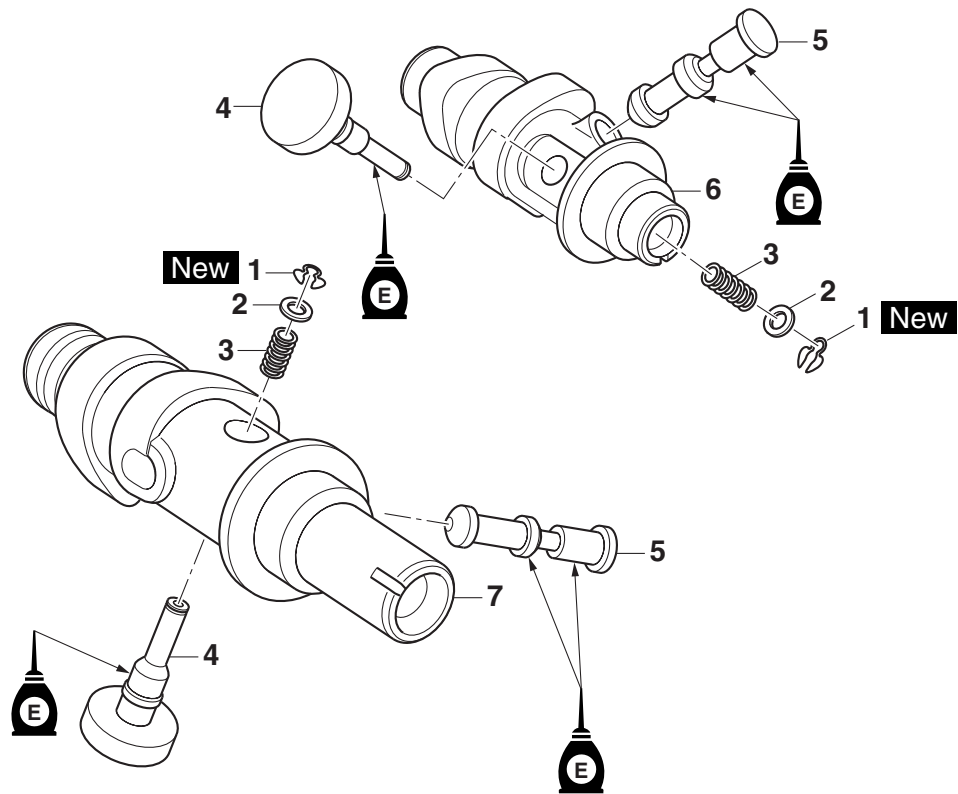

Order	Job/Parts to remove	Q'ty	Remarks
1	Circlip	2	
2	Washer	2	
3	Decompression cam spring	2	
4	Decompression cam	2	
5	Decompression pin	2	
6	Front cylinder camshaft	1	
7	Rear cylinder camshaft	1	
			For assembly, reverse the disassembly procedure.

ET1D71030

REMOVING THE CYLINDER HEAD COVERS

1. Remove:
 - Front cylinder
 - Rear cylinder "1"

NOTE:

Due to the small clearance between the frame and the rear cylinder head cover, the three bolts "2" cannot be removed when the cover is in place. Loosen the bolts, and then remove the cover from the right side of the vehicle, making sure that the bolts do not scratch the rocker arms or other engine parts.

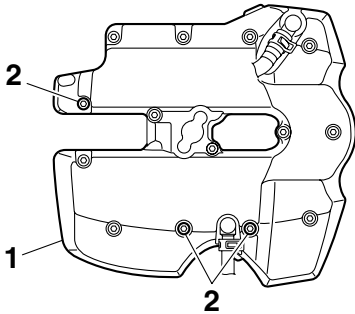

EAS23790

REMOVING THE ROCKER ARMS, PUSH RODS AND VALVE LIFTERS

1. Align:
 - TDC mark "a" on the crankshaft position sensor rotor (with the pointer "b" on the clutch cover)

- a. Turn the crankshaft counterclockwise.
- b. When piston #1 is at TDC on the compression stroke, align the TDC mark "a" on the crankshaft position sensor rotor with the pointer "b" on the clutch cover.

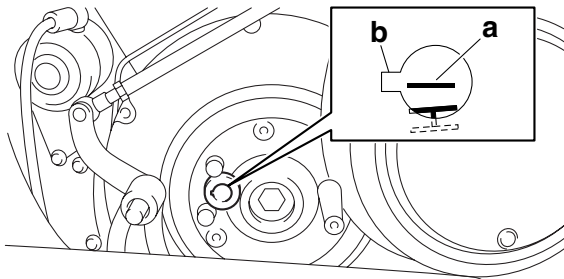

- c. Check the camshaft drive gear mark "c" position and camshaft driven gear mark "d" position as shown. If the marks are not aligned, turn the crankshaft counterclockwise 360 degrees and re-check step (b).

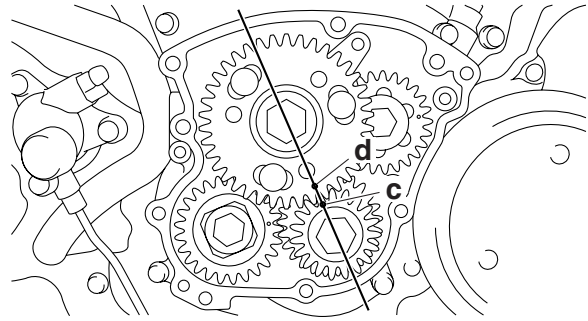

2. Remove:
 - Rocker arm bases (with the rocker arms)

3. Remove:
 - Valve lifters

NOTE:

Make a note of the position of each valve lifter so that they can be installed in the correct place.

	R	F
EX		
IN		

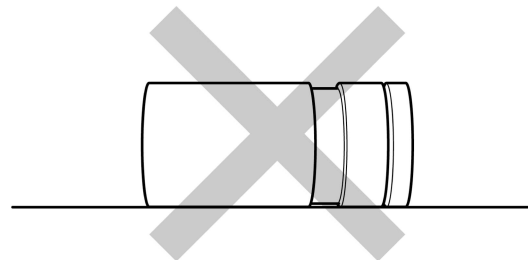

EAS23830

REMOVING THE CAMSHAFTS

1. Loosen:
 - Camshaft driven gear bolt "1"

NOTE:

- Place a folded copper washer "2" between the teeth of the camshaft drive gear and camshaft driven gear in order to lock them.
- Do not damage the teeth of the camshaft drive and camshaft driven gears.

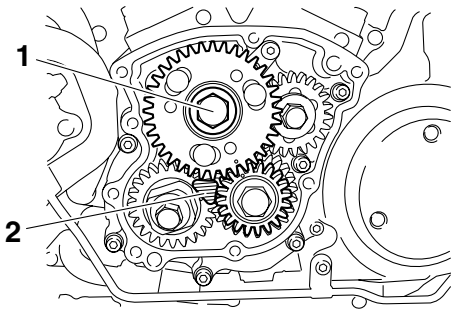

2. Remove:

- Camshaft driven gear
- Straight key

NOTE:

Cover the crankcase hole with a clean rag to prevent the straight key from falling into the crankcase.

3. Loosen:

- Front cylinder camshaft gear bolt "1"

NOTE:

- Place a folded copper washer "2" between the teeth of the front cylinder camshaft gear and rear cylinder camshaft gear in order to lock them.
- Do not damage the teeth of the front cylinder camshaft and rear cylinder camshaft gears.

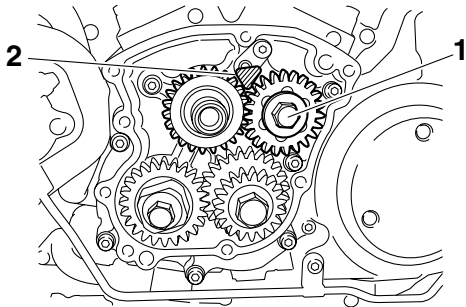

4. Remove:

- Rear cylinder camshaft gear
- Front cylinder camshaft gear
- Straight key

NOTE:

Cover the crankcase hole with a clean rag to prevent the straight key from falling into the crankcase.

5. Loosen:

- Camshaft drive gear bolt "1"
- Right balancer driven gear bolt "2"

NOTE:

- Place a folded copper washer "3" between the teeth of the right balancer drive gear and right balancer driven gear in order to lock them.
- Place a folded copper washer "4" between the teeth of the right balancer drive gear and right balancer driven gear in order to lock them.
- Do not damage the teeth of the right balancer drive and right balancer driven gears.

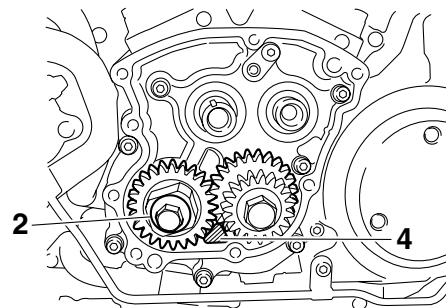
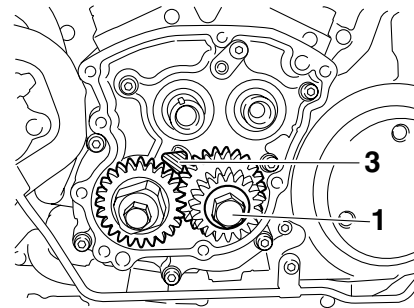

6. Remove:

- Right balancer driven gear
- Camshaft drive gear
- Right balancer drive gear
- Straight keys

NOTE:

Cover the crankcase hole with a clean rag to prevent the straight keys from falling into the crankcase.

7. Remove:

- Oil delivery pipe 1 "1"
- Camshaft cover "2"

NOTE:

Loosen each bolt 1/4 of a turn at a time, in stages and in a crisscross pattern. After all of the bolts are fully loosened, remove them.

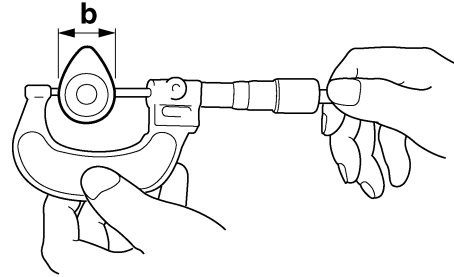
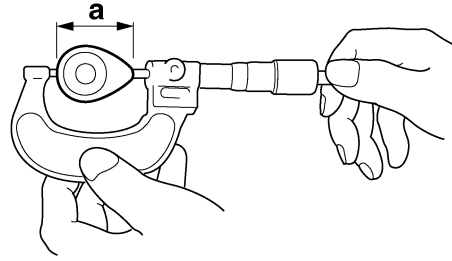
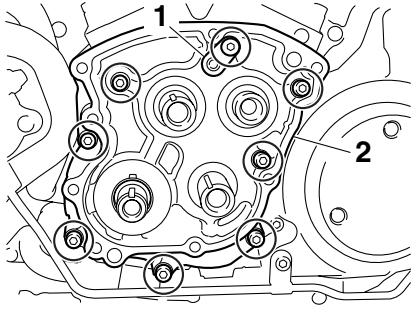

EAS23860

CHECKING THE CAMSHAFTS

1. Check:

- Cam
Blue discoloration/pitting/scratches → Replace the camshaft.

2. Measure:

- Cam dimensions A “a” and B “b”
Out of specification → Replace the camshaft.



Camshaft lobe dimensions

Intake A

42.532–42.632 mm (1.6745–1.6784 in)

Limit

42.432 mm (1.6705 in)

Intake B

35.950–36.050 mm (1.4154–1.4193 in)

Limit

35.850 mm (1.4114 in)

Exhaust A

42.530–42.630 mm (1.6744–1.6783 in) (cylinder #1)
42.531–42.631 mm (1.6744–1.6784 in) (cylinder #2)

Limit

42.430 mm (1.6705 in) (cylinder #1)
42.431 mm (1.6705 in) (cylinder #2)

Exhaust B

35.950–36.050 mm (1.4154–1.4193 in)

Limit

35.850 mm (1.4114 in)

3. Measure:

- Camshaft journal diameter (crankcase side) “a”
Out of specification → Replace the camshaft.



Camshaft journal diameter (crankcase side)

24.957–24.980 mm (0.9826–0.9835 in)

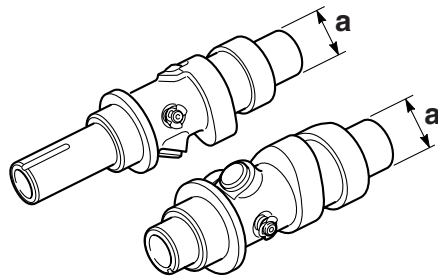

4. Measure:

- Camshaft journal diameter (camshaft cover side) “a”
Out of specification → Replace the camshaft.



Camshaft journal diameter (camshaft cover side)

27.957–27.980 mm (1.1007–1.1016 in)

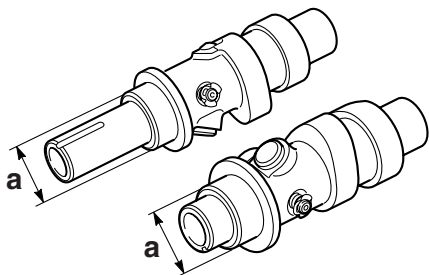

5. Measure:
- Crankcase hole inside diameter “a”
Out of specification → Replace the crankcase.



Crankcase hole inside diameter
25.000–25.021 mm (0.9843–0.9851 in)

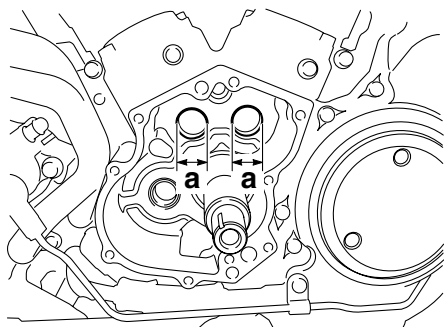

6. Measure:
- Camshaft cover hole inside diameter “a”
Out of specification → Replace the camshaft cover.



Camshaft cover hole inside diameter
28.000–28.021 mm (1.1024–1.1032 in)

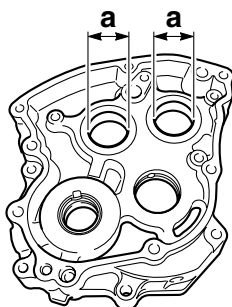

7. Calculate:
- Camshaft-to-crankcase clearance
Out of specification → Replace the defective part(s).

NOTE: _____

Calculate the clearance by subtracting the camshaft journal diameter (crankcase side) from the crankcase hole inside diameter.



Camshaft to crankcase clearance
0.020–0.064 mm (0.0008–0.0025 in)

8. Calculate:
- Camshaft to camshaft cover clearance
Out of specification → Replace the defective part(s).

NOTE: _____

Calculate the clearance by subtracting the camshaft journal diameter (camshaft cover side) from the camshaft cover hole inside diameter.



Camshaft to camshaft cover clearance
0.020–0.064 mm (0.0008–0.0025 in)

9. Check:
- Camshaft drive gears
 - Camshaft driven gears
 - Front cylinder camshaft gears
 - Rear cylinder camshaft gears
- Chips/pitting/roughness/wear → Replace the defective part(s).

EAS23890

CHECKING THE ROCKER ARMS AND ROCKER ARM SHAFTS

The following procedure applies to all of the rocker arms and rocker arm shafts.

1. Check:
 - Rocker arm
Damage/wear → Replace.
2. Check:
 - Rocker arm shaft
Blue discoloration/excessive wear/pitting/scratches → Replace or check the lubrication system.
3. Measure:
 - Rocker arm inside diameter “a”
Out of specification → Replace.



Rocker arm inside diameter
18.000–18.018 mm (0.7087–0.7094 in)

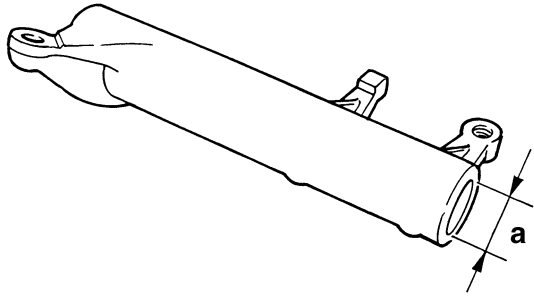

- Push rod end
Bends/damage → Replace.
2. Measure:
 - Push rod runout
Out of specification → Replace.



Valve push rod runout
0.3 mm (0.012 in)

4. Measure:

- Rocker arm shaft outside diameter “a”
Out of specification → Replace.



Rocker arm shaft outside diameter
17.976–17.991 mm (0.7077–0.7083 in)

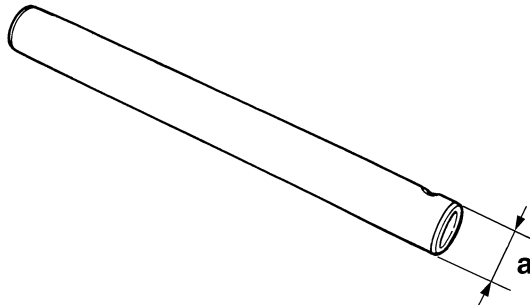
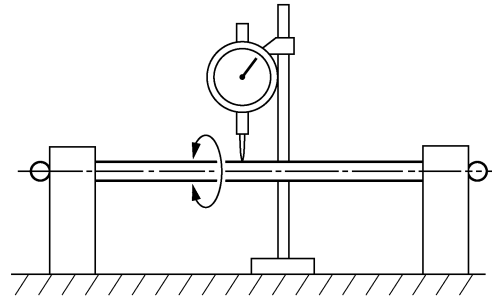

5. Calculate:

- Rocker arm to rocker arm shaft clearance

NOTE:

Calculate the clearance by subtracting the rocker arm shaft outside diameter from the rocker arm inside diameter.

Above 0.08 mm (0.003 in) → Replace the defective part(s).



Rocker-arm-to-rocker-arm-shaft clearance
0.009–0.042 mm (0.0004–0.0017 in)

EAS23920

CHECKING THE VALVE LIFTERS AND VALVE LIFTER CASES

1. Check:

- Valve lifter
Blue discoloration/excessive wear/pitting/scratches → Replace and check the lubrication system.

2. Check:

- Valve lifter case “1”
Damage/wear → Replace the valve lifter case.
- O-rings “2”
Damage/wear → Replace the O-ring.

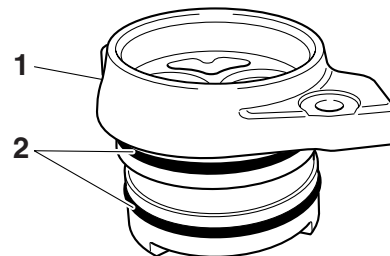

EAS23900

CHECKING THE ROCKER ARM BASES

1. Check:

- Rocker arm base
Cracks/damage → Replace.

EAS23910

CHECKING THE PUSH RODS

1. Check:

- Push rod

3. Measure:

- Valve lifter outside diameter “a”
Out of specification → Replace.



Valve lifter outside diameter (intake)
 22.962–22.974 mm (0.9040–0.9045 in)
Valve lifter outside diameter (exhaust)
 22.962–22.974 mm (0.9040–0.9045 in)

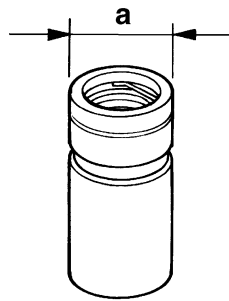

4. Measure:
- Valve lifter case inside diameter “a”
 Out of specification → Replace.



Valve lifter hole inside diameter (intake)
 23.000–23.021 mm (0.9055–0.9063 in)
Valve lifter hole inside diameter (exhaust)
 23.000–23.021 mm (0.9055–0.9063 in)

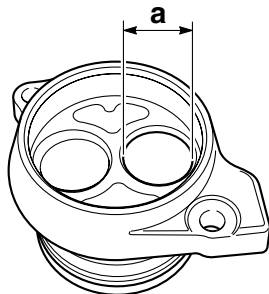

5. Calculate:
- Valve lifter-to-valve lifter case clearance

NOTE: _____
 Calculate the clearance by subtracting the valve lifter outside diameter from the valve lifter case inside diameter.

Above 0.072 mm (0.0028 in) → Replace the defective part(s).



Valve-lifter-to-valve-lifter-hole clearance
 0.026–0.059 mm (0.0010–0.0023 in)

EAS23930

CHECKING THE PUSH ROD COVER

1. Check:
 - Push rod cover
 Cranks/damage → Replace.
 - Seal
 Damage/wear → Replace the seal and O-ring as a set.

EAS23980

CHECKING THE DECOMPRESSION SYSTEM

1. Check:
 - Decompression system

NOTE:

- Check that the decompression pin “1” projects from the camshaft.
- Check that the decompression cam “2” and decompression pin “1” moves smoothly.

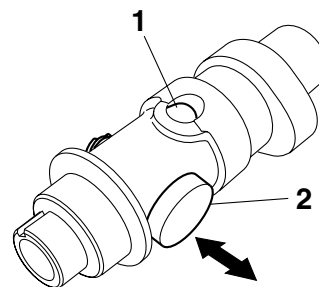

2. Check:
 - Decompression cam
 Damage/wear → Replace.

ET1D71031

CHECKING THE DECOMPRESSION CAM SPRING

The following procedure applies to all of the decompression cam springs.

1. Measure:
 - Decompression cam spring free length “a”
 Out of specification → Replace the decompression cam spring.



Decompression cam spring
Free length
 20.0 mm (0.79 in)
Limit
 19.0 mm (0.75 in)

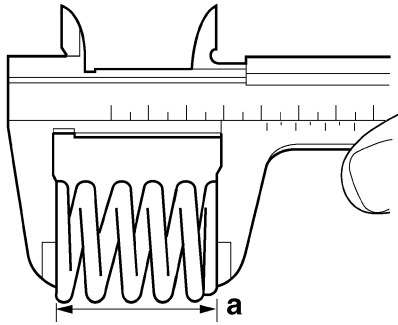

2. Measure:

- Compressed decompression cam spring force "a"
- Out of specification → Replace the decompression cam spring.



Decompression cam spring
Installed compression spring force
 0.1335–0.1631 N (0.0300–0.0367 lb) (0.0136–0.0166 kgf)
Installed length
 8.0 mm (0.31 in)

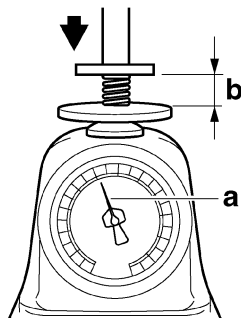

b. Installed length

EAS23990

CHECKING THE OIL DELIVERY PIPE

1. Check:

- Oil delivery pipe 1
 Damage → Replace.
 Obstruction → Wash and blow out with compressed air.
- O-rings
 Damage/wear → Replace.

EAS24030

INSTALLING THE CAMSHAFTS

1. Install:

- Camshafts

NOTE:

Lubricate molybdenum disulfide oil onto the camshaft journals and lobes.

2. Install:

- Camshaft cover 1 "1"
- Oil delivery pipe 1 "2"

NOTE:

Tighten the camshaft cover bolts in stages and in a crisscross pattern.

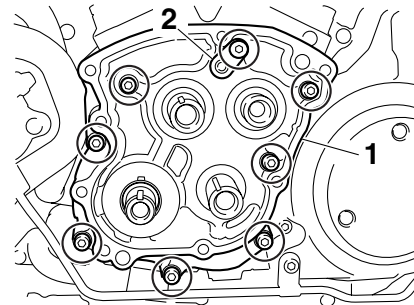

3. Install:

- Straight keys
- Right balancer drive gear "1"
- Right balancer driven gear "2"
- Camshaft driven gear

NOTE:

- Cover the crankcase hole with a clean rag to prevent the straight keys from falling into the crankcase.
- Align the punch mark "a" on the right balancer drive gear "1" with the punch mark "b" on the right balancer driven gear "2".

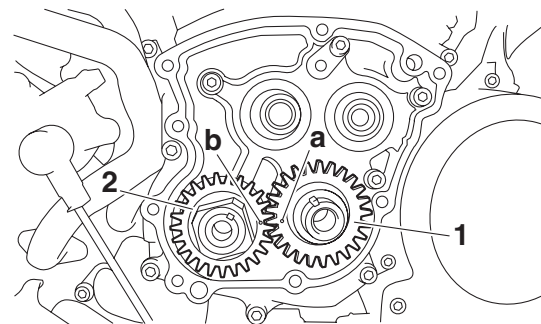

4. Tighten:

- Camshaft drive gear bolt "1"
- Right balancer driven gear bolt "2"



Camshaft drive gear bolt
 60 Nm (6.0 m·kg, 43 ft·lb)
Right balancer driven gear bolt
 40 Nm (4.0 m·kg, 29 ft·lb)

NOTE:

- Lubricate the camshaft drive gear bolt and right balancer driven gear bolt threads with engine oil.

- Place a folded copper washer “3” between the teeth of the right balancer drive gear and right balancer driven gear in order to lock them.
- Place a folded copper washer “4” between the teeth of the right balancer drive gear and right balancer driven gear in order to lock them.
- Do not damage the teeth of the right balancer drive and right balancer driven gears.
- After tightening the camshaft driven gear bolt, remove the copper washer to clean the teeth of the right balancer drive gear and right balancer driven gear.

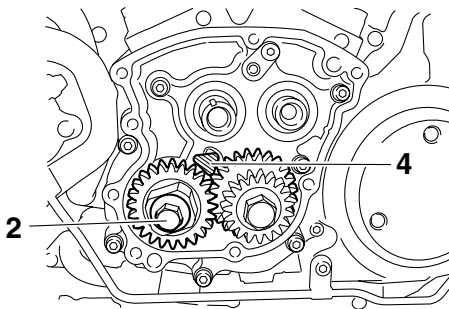
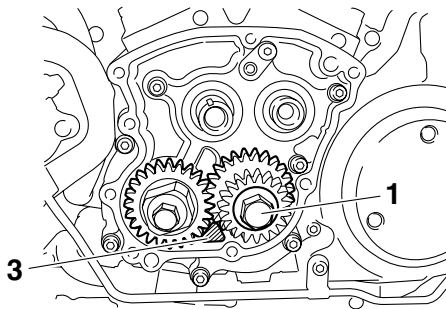

5. Install:

- Rear cylinder camshaft gear “1”
- Front cylinder camshaft gear “2”
- Washer “3”
- Conical spring washer “4”
- Washer “5”
- Circlip “6” **New**

NOTE:

- Align the projection “a” on the washer “3” with the punch mark “b” on the front cylinder camshaft gear.
- Install the conical spring washer “4” as shown in the illustration.
- Lubricate the front cylinder camshaft gear bolt threads with engine oil.

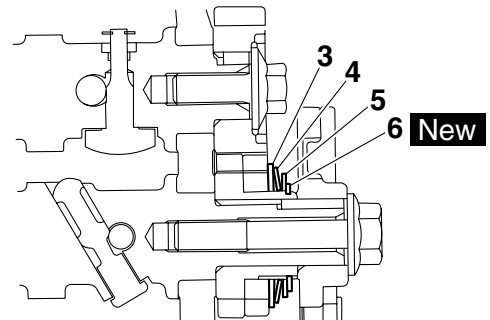
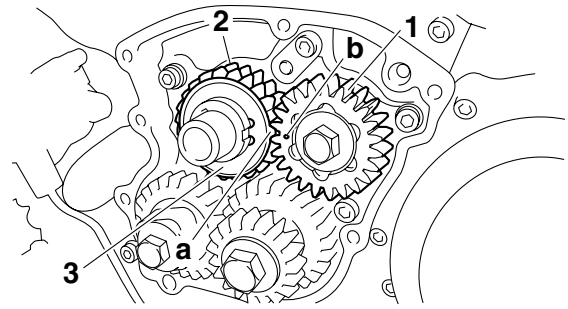

6. Tighten:

- Front cylinder camshaft gear bolt “1”

	Front cylinder camshaft gear bolt 40 Nm (4.0 m·kg, 29 ft·lb)
--	---

NOTE:

- Place a folded copper washer “2” between the teeth of the front cylinder camshaft gear and rear cylinder camshaft gear in order to lock them.
- Do not damage the teeth of the front cylinder camshaft and rear cylinder camshaft gears.
- After tightening the front cylinder camshaft gear bolt, remove the copper washer to clean the teeth of the front cylinder camshaft and rear cylinder camshaft gears.

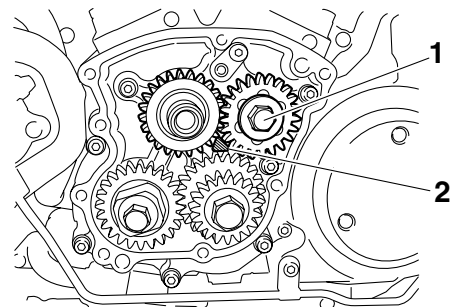

7. Install:

- Straight key
- Camshaft driven gear “1”

NOTE:

The crankshaft can be rotated smoothly when the spark plugs are removed.

EWA12880



WARNING

Be careful since the engine is hot.

- g. With piston #1 at TDC, count the indicated number of gear teeth and place marks “2” through “5” on the camshaft driven gear as shown. When these marks align between the centers of the camshaft drive and driven gears, the corresponding valve lifter is at its highest point.

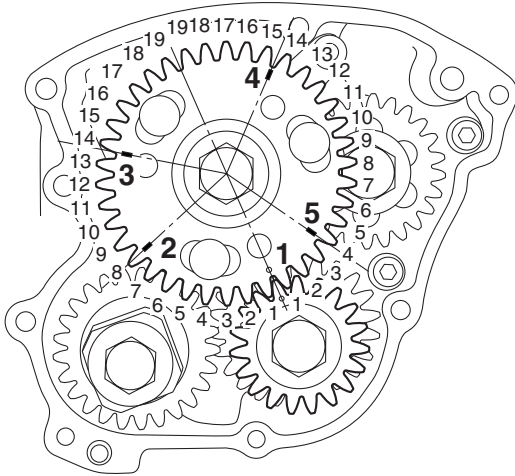
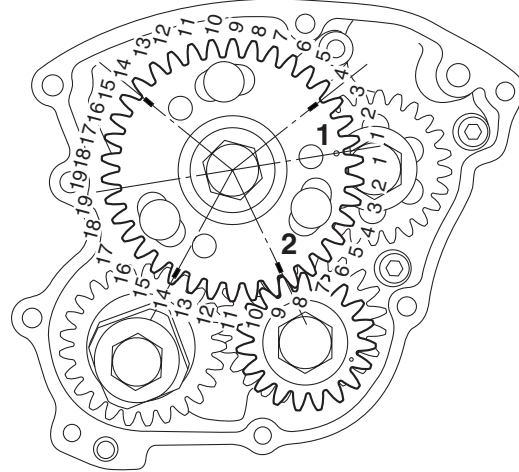

1. Piston #1 TDC punch mark
 2. Cylinder #2 intake valve at its highest point
 3. Cylinder #1 exhaust valve at its highest point
 4. Cylinder #1 intake valve at its highest point
 5. Cylinder #2 exhaust valve at its highest point
- h. Rotate the crankshaft until the mark (on the camshaft driven gear) for the valve lifter to be bled aligns with the camshaft drive gear as shown.
- Example:
For bleeding the cylinder #2 intake valve lifter, align mark “2” as shown.

1. Piston #1 TDC punch mark
2. Cylinder #2 intake valve at its highest point

- i. Leave the camshaft drive and driven gears aligned for five minutes to allow the valve lifter to bleed.
- j. If necessary, repeat steps (h) and (i) to bleed other valve lifters.



EAS24060

INSTALLING THE VALVE LIFTERS

1. Install:
 - Front valve lifter case
 - Rear valve lifter case
 - Valve lifters

	<p>Valve lifter case bolt 10 Nm (1.0 m·kg, 7.2 ft·lb) LOCTITE®</p>
--	---

NOTE:

- Install the valve lifter in the correct place.
- After installing the valve lifters, fill the tops of them with engine oil.

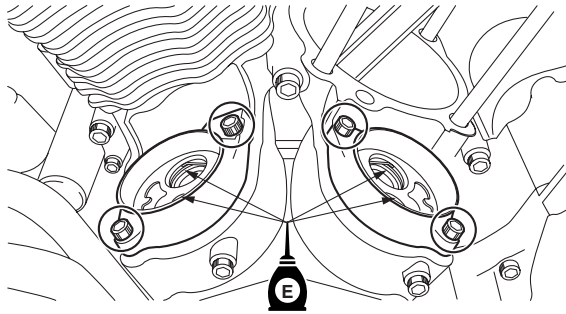

2. Install:

- Push rod covers “1”

NOTE:

Install the push rod covers so that their paint marks “a” are facing towards the cylinder heads.

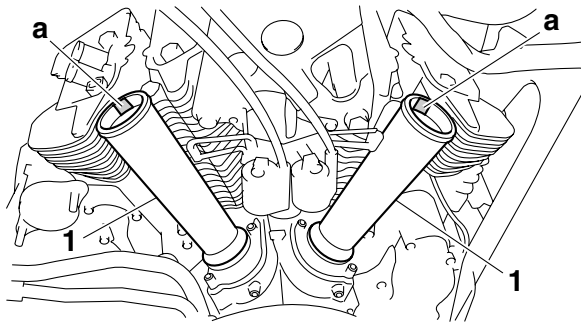

EAS24070

INSTALLING THE ROCKER ARMS AND PUSH RODS

The following procedure applies to both cylinders.

1. Install:

- Rocker arms “1”
- Rocker arm shafts “2”
(onto rocker arm base)

NOTE:

The thread hole “a” of the rocker arm shaft must face to the outside.

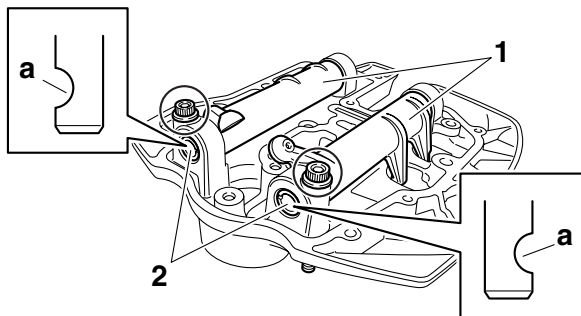

2. Install:

- Rocker arm base
(with rocker arms)
- Push rods

- Put the rocker arm base on the cylinder head.
- Install the push rods.

NOTE:

- Be sure to correctly install the push rods between the rocker arms and valve lifters as shown. The illustration is viewed from the right side of the vehicle.
- The lengths of push rod 1 and push rod 2 are different. Therefore, be sure to install them in the proper position.
- Lubricate the push rod end balls with engine oil.

A

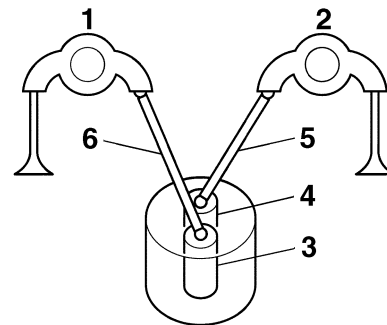

B

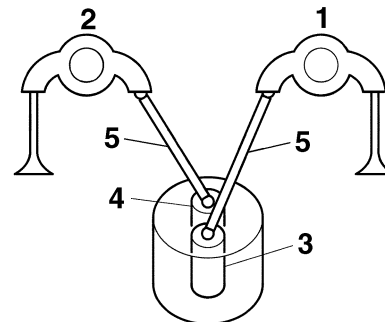

A. Rear cylinder

B. Front cylinder

1. Exhaust side rocker arm

2. Intake side rocker arm

3. Exhaust valve lifter

4. Intake valve lifter

5. Push rod 1 l = 286.5 mm (11.280 in)

6. Push rod 2 l = 288.5 mm (11.358 in)

- Install the rocker arm base bolts (M6) “1” and rocker arm base bolts (M8) “2” and “3”.

NOTE:

Tighten the rocker arm base bolts in stages and in a crisscross pattern.



Rocker arm base bolt (M6)
10 Nm (1.0 m·kg, 7.2 ft·lb)
Rocker arm base bolt (M8)
24 Nm (2.4 m·kg, 17ft·lb)

Bolts "2": l = 45 mm (1.77 in)

Bolts "3": l = 70 mm (2.76 in)

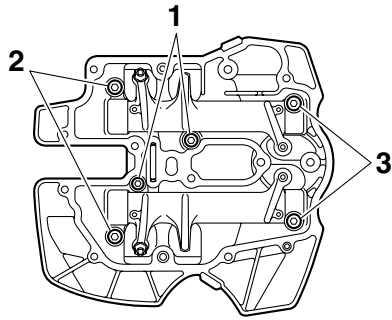

EAS24080

INSTALLING THE CYLINDER HEAD COVERS

1. Install:

- Rear cylinder head cover "1"
- Front cylinder head cover "2"

NOTE:

Due to the small clearance between the frame and the rear cylinder head cover, the three bolts "3" cannot be installed when the cover is in place. Set the bolts in the cylinder head cover, and then install the cover from the right side of the vehicle.



**Cylinder head cover bolt
10 Nm (1.0 m·kg, 7.2 ft·lb)**

Bolts "4": l = 40 mm (1.57 in)

Bolts "5": l = 60 mm (2.36 in)

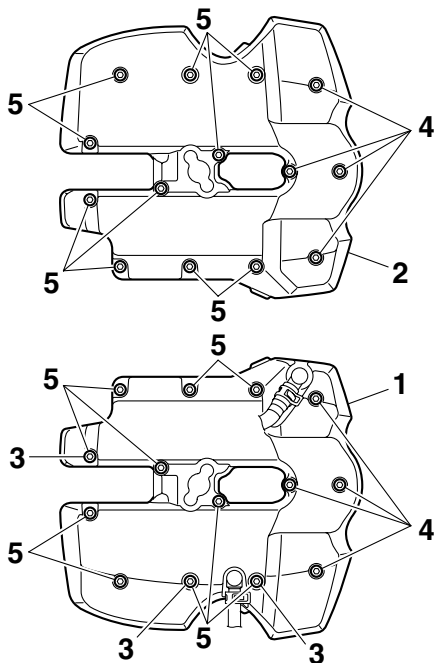

ET1D71032

INSTALLING THE SHIFT PEDAL ASSEMBLY (for XV19S(C)/ XV19M(C)/ XV19CTS(C)/ XV19CTM(C))

1. Install:

- Shift pedal assembly "1"

NOTE:

Align the mark "a" on the shift pedal shaft with the slot in the shift pedal.

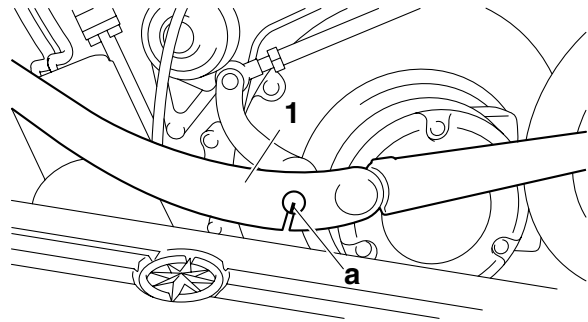

EAS24110

CYLINDER HEADS

Removing the cylinder heads

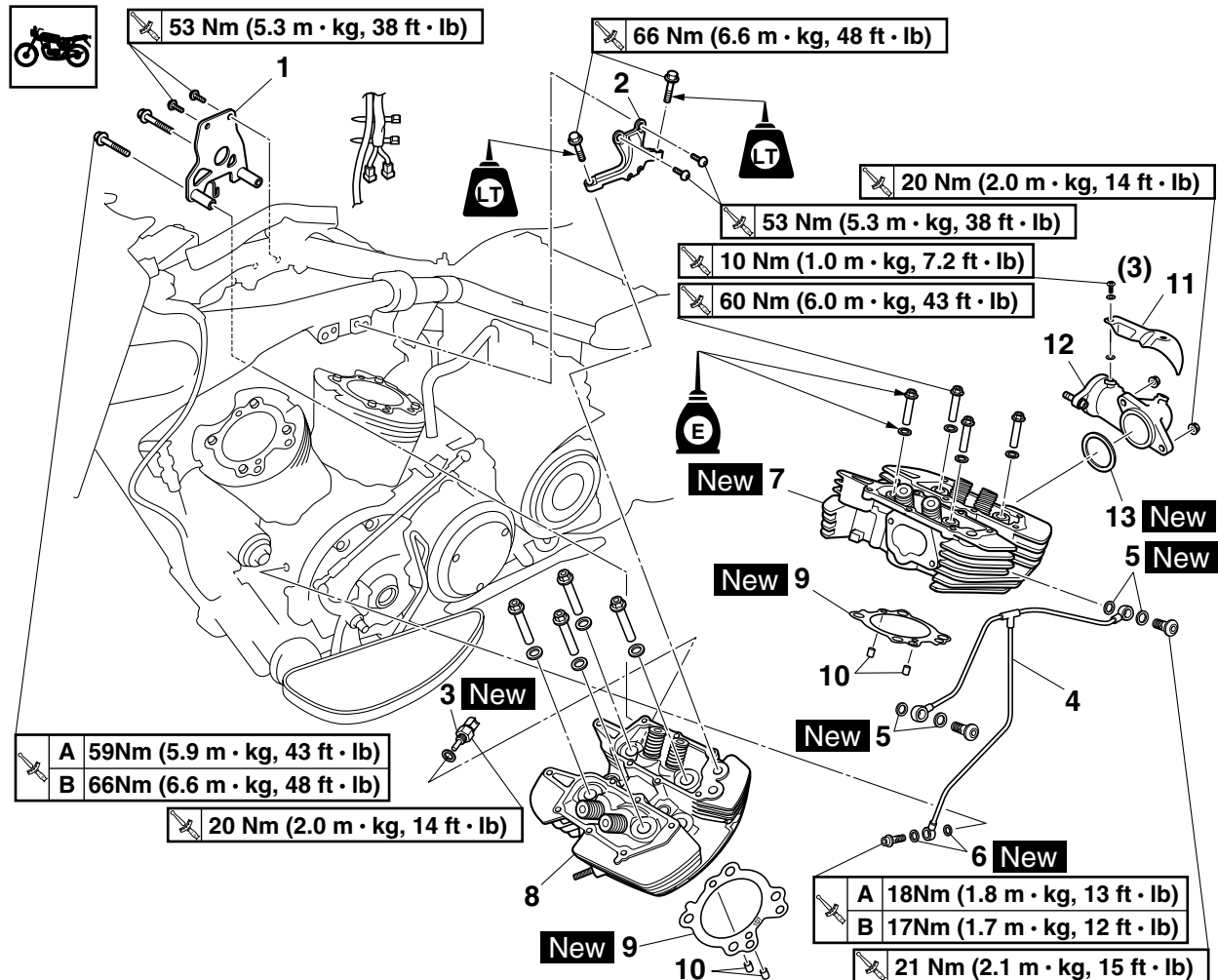

Order	Job/Parts to remove	Q'ty	Remarks
	Cylinder-#1 ignition coil bracket		Refer to "ENGINE REMOVAL" on page 5-1.
	Throttle bodies/Intake manifolds		Refer to "THROTTLE BODIES" on page 6-7.
	Cylinder head covers/Rocker arms		Refer to "CAMSHAFTS" on page 5-17.
1	Engine bracket (right upper side)	1	
2	Engine bracket (left upper side)	1	
3	Engine temperature sensor	1	
4	Oil pipe 1	1	
5	Copper washer	4	
6	Copper washer	2	
7	Rear cylinder head	1	
8	Front cylinder head	1	
9	Cylinder head gasket	2	
10	Dowel pin	4	
11	Rear exhaust pipe joint cover	1	
12	Rear exhaust pipe joint	1	

CYLINDER HEADS

Removing the cylinder heads

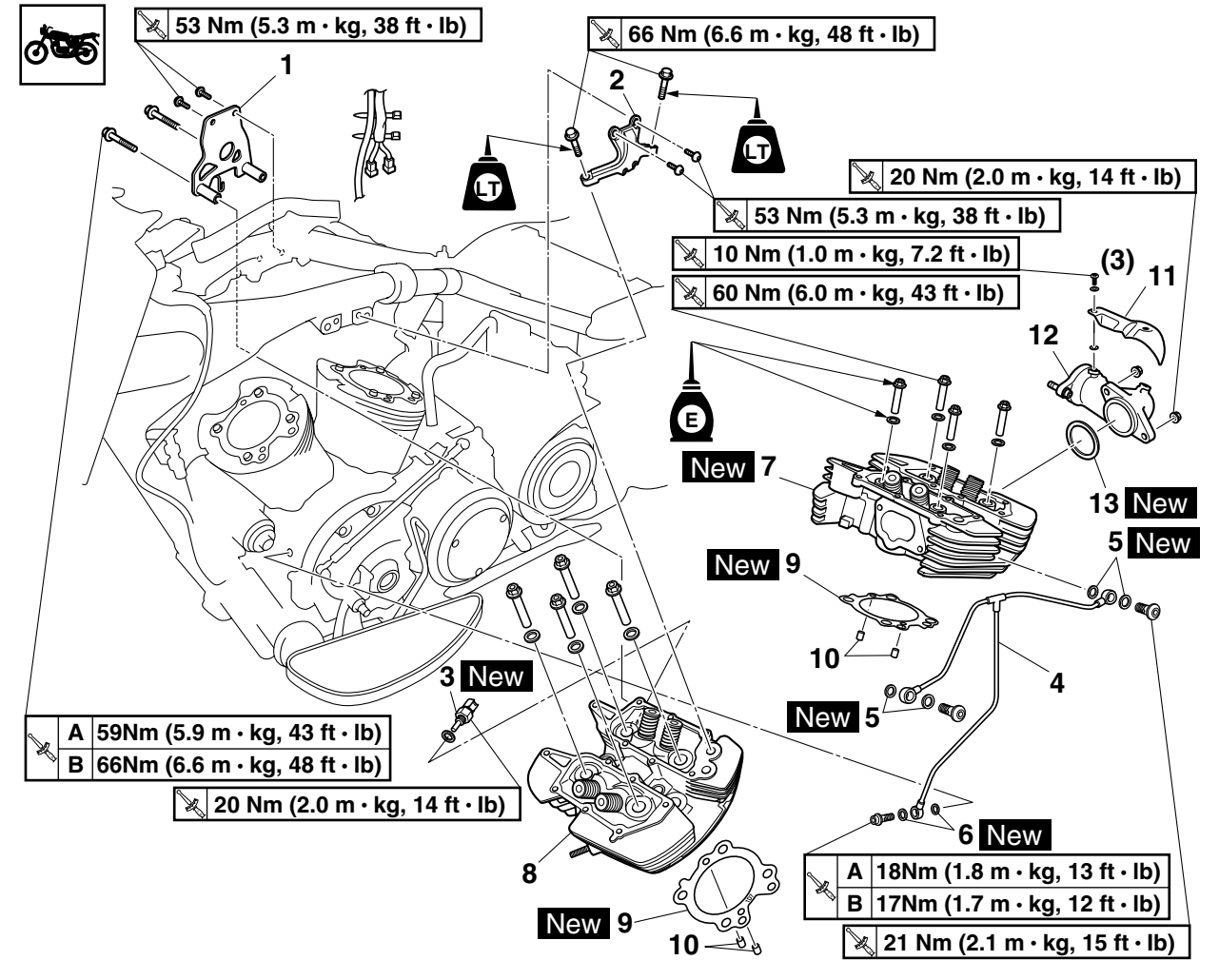

Order	Job/Parts to remove	Q'ty	Remarks
13	Rear exhaust pipe gasket	1	
			For installation, reverse the removal procedure.

A: For XV19S(C)/ XV19M(C)/ XV19CTS(C)/ XV19CTM(C)
 B: For XV19CS(C)/ XV19C(C)

EAS24140

REMOVING THE CYLINDER HEADS

1. Remove:
 - Cylinder head nuts

NOTE:

- Loosen the nuts in the proper sequence as shown.
- Loosen each nut 1/2 of a turn at a time. After all of the nuts are fully loosened, remove them.

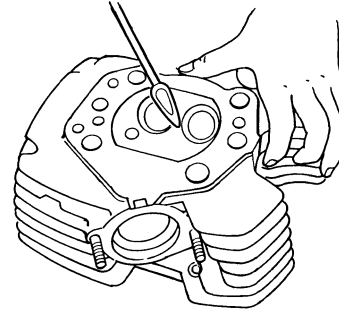

A

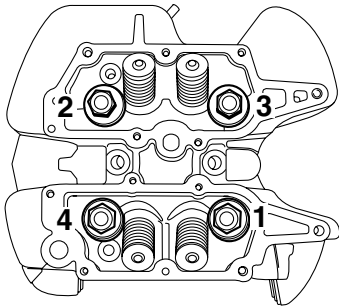

B

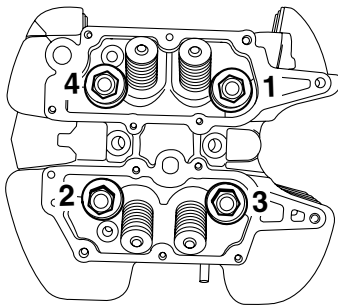

- A. Front cylinder
- B. Rear cylinder

EAS24170

CHECKING THE CYLINDER HEADS

The following procedure applies to all of the cylinder heads.

1. Eliminate:
 - Combustion chamber carbon deposits (with a rounded scraper)

NOTE:

Do not use a sharp instrument to avoid damaging or scratching:

- Spark plug bore threads
- Valve seats

2. Check:
 - Cylinder head
Damage/scratches → Replace.
3. Measure:
 - Cylinder head warpage
Out of specification → Resurface the cylinder head.



Warpage limit
0.03 mm (0.0012 in)

- a. Place a straightedge and a thickness gauge across the cylinder head.
- b. Measure the warpage.
- c. If the limit is exceeded, resurface the cylinder head as follows.
- d. Place a 400–600 grit wet sandpaper on the surface plate and resurface the cylinder head using a figure-eight sanding pattern.

NOTE:

To ensure an even surface, rotate the cylinder head several times.

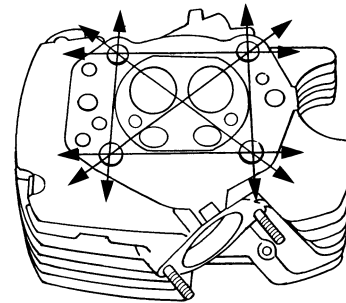

EAS24220

CHECKING THE OIL PIPE

1. Check:
 - Oil pipe 1
Damage → Replace.
Obstruction → Wash and blow out with compressed air.

EAS24250

INSTALLING THE CYLINDER HEADS

1. Install:

- Cylinder head gasket “1” **New**
- Dowel pins “2”

NOTE:

The “1D7” mark on the cylinder head gasket must face up and towards the left side of the cylinder.

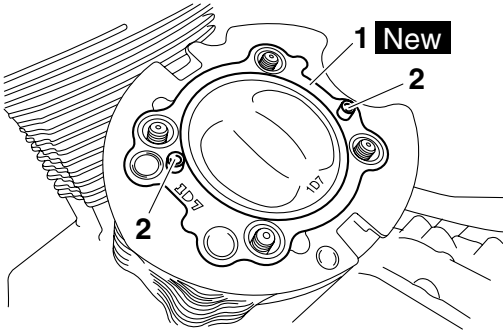

2. Install:

- Cylinder heads
- Washers
- Cylinder head nuts

NOTE:

Lubricate the cylinder head nuts and washers with engine oil.

3. Tighten:

- Cylinder head nuts



Cylinder head nut
60 Nm (6.0 m·kg, 43 ft·lb)

NOTE:

Tighten the cylinder head nuts in the proper tightening sequence as shown and torque them in two stages.

A

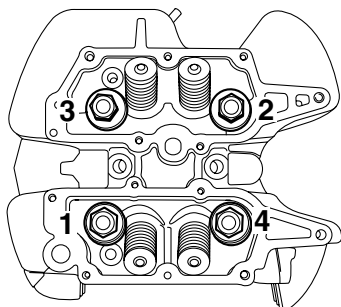

B

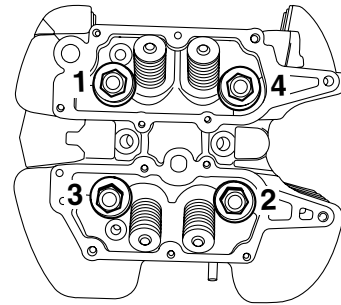

- A. Front cylinder
- B. Rear cylinder

4. Install:

- Copper washers **New**
- Oil pipe 1
- Oil pipe union bolt (M8)



Oil pipe union bolt (M8)
XV19S(C)/ XV19M(C)/
XV19CTS(C)/ XV19CTM(C):
18 Nm (1.8 m·kg, 13 ft·lb)
XV19CS(C)/ XV19C(C):
17 Nm (1.7 m·kg, 12 ft·lb)

- Oil pipe union bolts (M10)



Oil pipe union bolt (M10)
21 Nm (2.1 m·kg, 15 ft·lb)

NOTE:

Tighten the three union bolts evenly, and then torque them to specification.

5. Install:

- Engine bracket (right upper side)
- Engine bracket bolts (right upper side)
- Engine mounting bolts (right upper side)
- Engine bracket (left upper side)
- Engine bracket bolts (left upper side)
- Engine mounting bolts (left upper side)

NOTE:

- Apply locking agent (LOCTITE®) to the threads of the engine mounting bolts (left upper side).
- Do not fully tighten the bolts.

6. Tighten:

- Engine mounting bolts (right upper side)
- Engine mounting bolts (left upper side)
- Engine bracket bolts (right upper side)
- Engine bracket bolts (left upper side)



Engine mounting bolt (right upper side)

**XV19S(C)/ XV19M(C)/
XV19CTS(C)/ XV19CTM(C):**

59 Nm (5.9 m·kg, 43 ft·lb)

XV19CS(C)/ XV19C(C):

66 Nm (6.6 m·kg, 48 ft·lb)

Engine mounting bolt (left upper side)

66 Nm (6.6 m·kg, 48 ft·lb)

LOCTITE®

Engine bracket bolt (right upper side)

53 Nm (5.3 m·kg, 38 ft·lb)

Engine bracket bolt (left upper side)

53 Nm (5.3 m·kg, 38 ft·lb)

EAS24270

VALVES AND VALVE SPRINGS

Removing the valves and valve springs

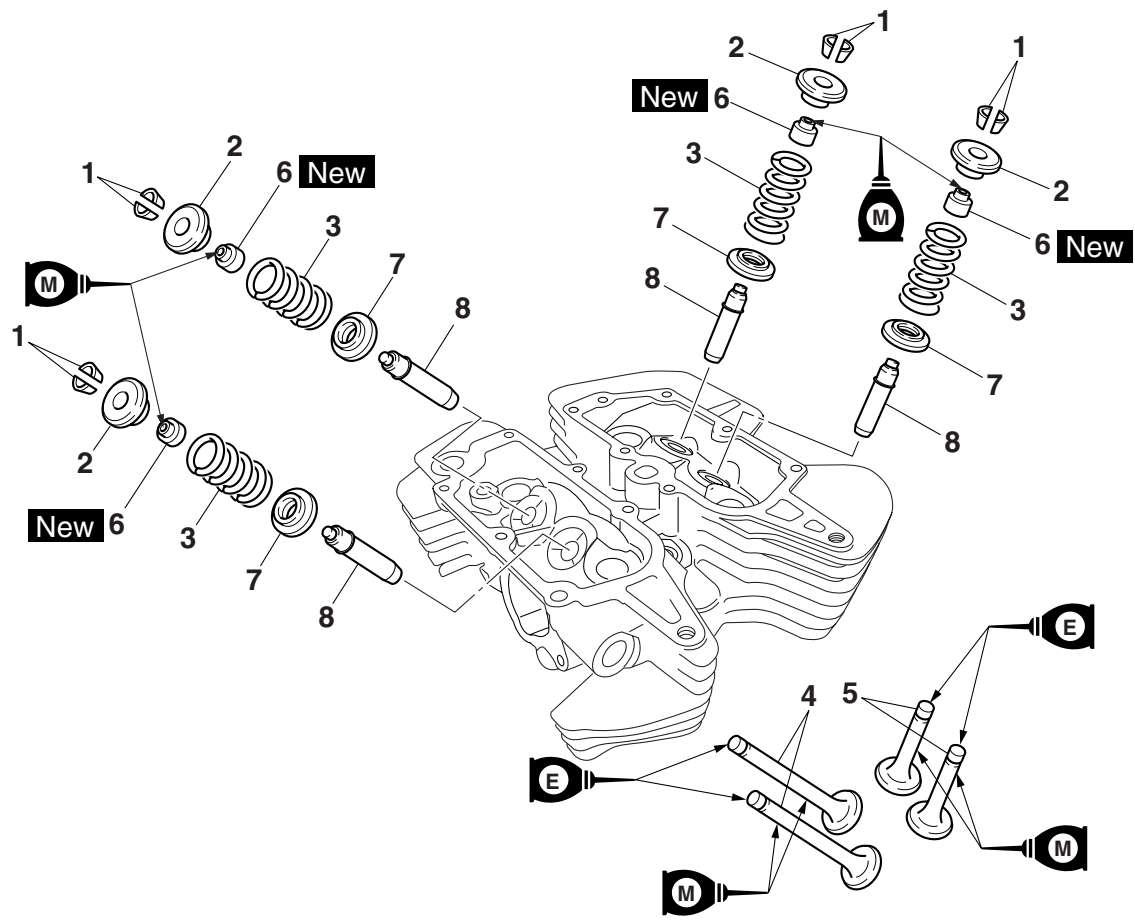

Order	Job/Parts to remove	Q'ty	Remarks
			The following procedure applies to both cylinders.
	Cylinder heads		Refer to "CYLINDER HEADS" on page 5-36.
1	Valve cotter	8	
2	Upper spring seat	4	
3	Valve spring	4	
4	Intake valve	2	
5	Exhaust valve	2	
6	Valve stem seal	4	
7	Lower spring seat	4	
8	Valve guide	4	
			For installation, reverse the removal procedure.

EAS24280

REMOVING THE VALVES

The following procedure applies to all of the valves and related components.

NOTE:

Before removing the internal parts of the cylinder head (e.g., valves, valve springs, valve seats), make sure the valves properly seal.

1. Check:

- Valve sealing

Leakage at the valve seat → Check the valve face, valve seat, and valve seat width.

Refer to “CHECKING THE VALVE SEATS” on page 5-44.

- Pour a clean solvent “a” into the intake and exhaust ports.
- Check that the valves properly seal.

NOTE:

There should be no leakage at the valve seat “1”.

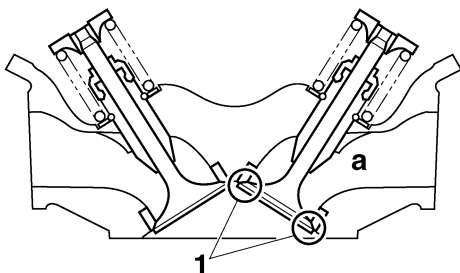

2. Remove:

- Valve cotters

NOTE:

Remove the valve cotters by compressing the valve springs with the valve spring compressor set “1”.



Valve spring compressor
90890-04019
YM-04019

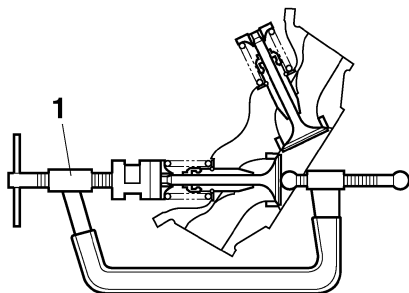

3. Remove:

- Upper spring seat “1”
- Valve spring “2”
- Valve “3”
- Valve stem seal “4”
- Lower spring seat “5”

NOTE:

Identify the position of each part very carefully so that it can be reinstalled in its original place.

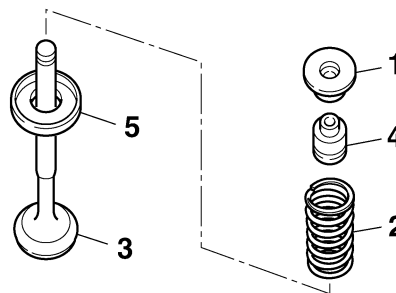

EAS24290

CHECKING THE VALVES AND VALVE GUIDES

The following procedure applies to all of the valves and valve guides.

1. Measure:

- Valve-stem-to-valve-guide clearance
Out of specification → Replace the valve guide.

$$\text{Valve-stem-to-valve-guide clearance} = \text{Valve guide inside diameter "a"} - \text{Valve stem diameter "b"}$$



Valve-stem-to-valve-guide clearance (intake)

0.010–0.037 mm (0.0004–0.0015 in)

Limit

0.080 mm (0.0032 in)

Valve-stem-to-valve-guide clearance (exhaust)

0.025–0.052 mm (0.0010–0.0020 in)

Limit

0.100 mm (0.0039 in)

VALVES AND VALVE SPRINGS

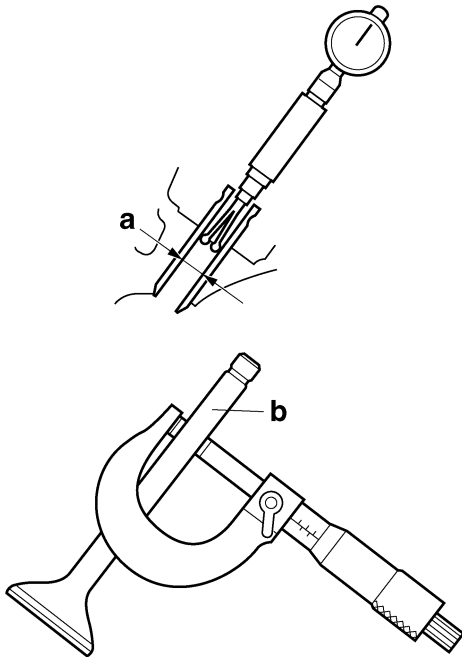

2. Replace:
- Valve guide

NOTE:

To ease valve guide removal and installation, and to maintain the correct fit, heat the cylinder head to 100 °C (212 °F) in an oven.

- a. Remove the valve guide with the valve guide remover "1".

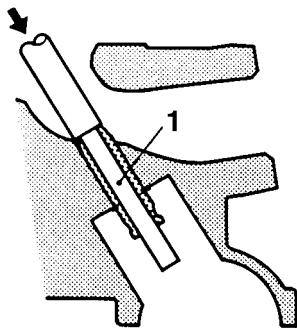

- b. Install the new valve guide with the valve guide installer "2" and valve guide remover "1".

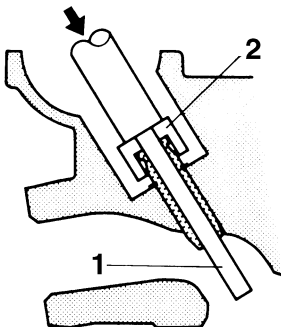

- c. After installing the valve guide, bore the valve guide with the valve guide reamer "3" to obtain the proper valve-stem-to-valve-guide clearance.

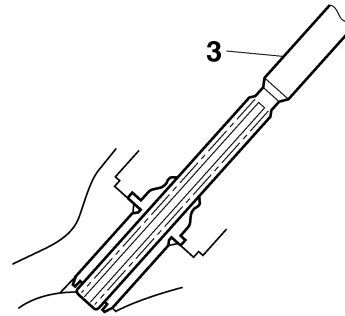

NOTE:

After replacing the valve guide, reface the valve seat.



Valve guide remover (ø6)
90890-04064
Valve guide remover (6.0 mm)
YM-04064-A
Valve guide installer (ø6)
90890-04065
Valve guide installer (6.0 mm)
YM-04065-A
Valve guide reamer (ø6)
90890-04066
Valve guide reamer (6.0 mm)
YM-04066

3. Eliminate:

- Carbon deposits
(from the valve face and valve seat)

4. Check:

- Valve face
Pitting/wear → Grind the valve face.
- Valve stem end
Mushroom shape or diameter larger than the body of the valve stem → Replace the valve.

5. Measure:

- Valve margin thickness D "a"
Out of specification → Replace the valve.



Valve margin thickness D (intake)
1.15–1.45 mm (0.0453–0.0571 in)
Limit
0.4 mm (0.02 in)
Valve margin thickness D (exhaust)
1.15–1.45 mm (0.0453–0.0571 in)
Limit
0.4 mm (0.02 in)

ECA13790

CAUTION:

Do not let the lapping compound enter the gap between the valve stem and the valve guide.

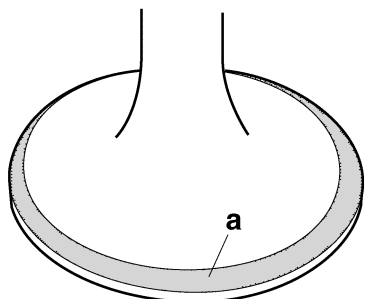

- b. Apply molybdenum disulfide oil onto the valve stem.

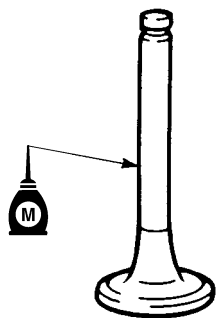

- c. Install the valve into the cylinder head.
 d. Turn the valve until the valve face and valve seat are evenly polished, then clean off all of the lapping compound.

NOTE:

For the best lapping results, lightly tap the valve seat while rotating the valve back and forth between your hands.

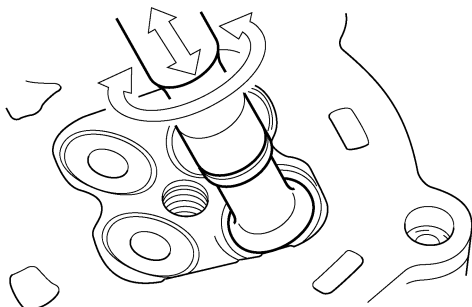

- e. Apply a fine lapping compound to the valve face and repeat the above steps.
 f. After every lapping procedure, be sure to clean off all of the lapping compound from the valve face and valve seat.

- g. Apply Mechanic's blueing dye (Dykem) "b" onto the valve face.

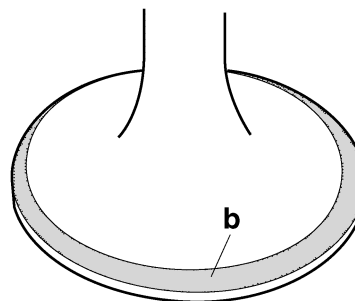

- h. Install the valve into the cylinder head.
 i. Press the valve through the valve guide and onto the valve seat to make a clear impression.
 j. Measure the valve seat width "c" again. If the valve seat width is out of specification, reface and lap the valve seat.

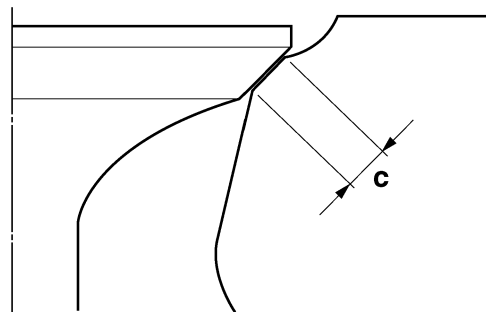

EAS24310

CHECKING THE VALVE SPRINGS

The following procedure applies to all of the valve springs.

1. Measure:
 - Valve spring free length "a"
 - Out of specification → Replace the valve spring.

	Free length (intake)	46.71 mm (1.84 in)
	Limit	44.71 mm (1.76 in)
	Free length (exhaust)	46.71 mm (1.84 in)
	Limit	44.71 mm (1.76 in)

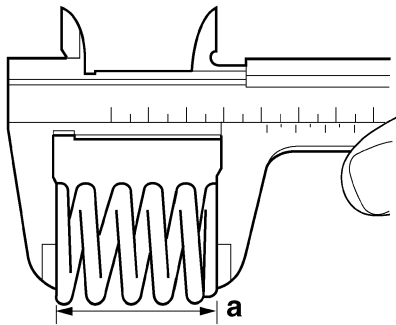

2. Measure:

- Compressed valve spring force "a"
Out of specification → Replace the valve spring.



Installed compression spring force (intake)
217.00–249.00 N (48.78–55.98 lb)
(22.13–25.39 kgf)
Installed compression spring force (exhaust)
217.00–249.00 N (48.78–55.98 lb)
(22.13–25.39 kgf)
Installed length (intake)
32.66 mm (1.29 in)
Installed length (exhaust)
32.66 mm (1.29 in)

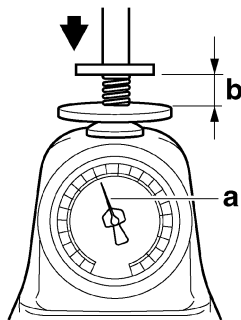

b. Installed length

3. Measure:

- Valve spring tilt "a"
Out of specification → Replace the valve spring.



Spring tilt (intake)
2.5 °/2.0 mm
Spring tilt (exhaust)
2.5 °/2.0 mm

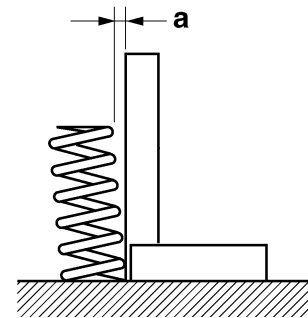

EAS24340

INSTALLING THE VALVES

The following procedure applies to all of the valves and related components.

1. Deburr:

- Valve stem end
(with an oil stone)

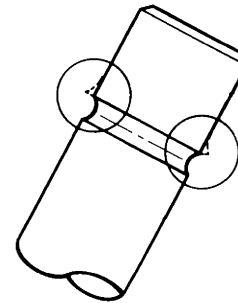

2. Lubricate:

- Valve stem "1"
- Valve stem seal "2"
(with the recommended lubricant)



Recommended lubricant
Molybdenum disulfide oil

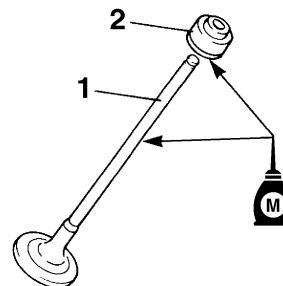

3. Install:

- Valve guide "1"
- Lower spring seat "2"
- Valve stem seal "3"
- Valve "4"
- Valve spring "5"
- Upper spring seat "6"
(into the cylinder head)

VALVES AND VALVE SPRINGS

NOTE:

- Make sure each valve is installed in its original place.
- Install the valve springs with the larger pitch “a” facing up.

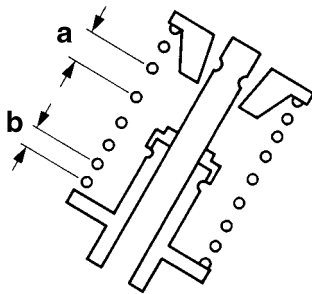
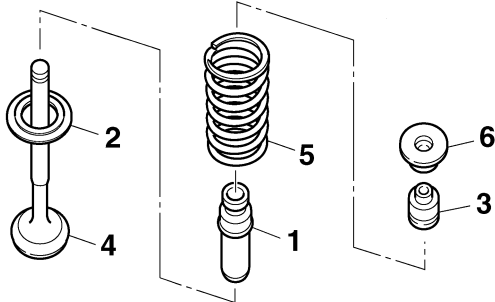

b. Smaller pitch

4. Install:

- Valve cotters

NOTE:

Install the valve cotters by compressing the valve springs with the valve spring compressor set “1”.



Valve spring compressor
90890-04019
YM-04019

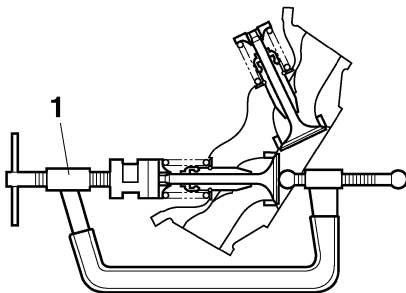

5. To secure the valve cotters onto the valve stem, lightly tap the valve tip with a soft-face hammer.

ECA13800

CAUTION:

Hitting the valve tip with excessive force could damage the valve.

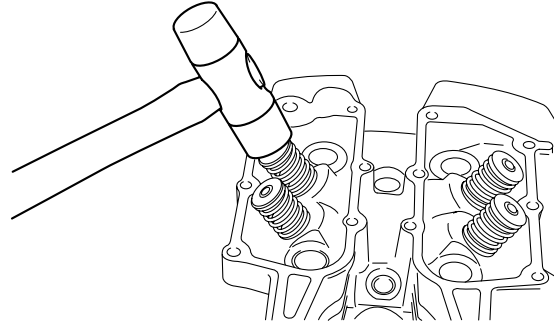

EAS24360

CYLINDERS AND PISTONS

Removing the cylinders and pistons

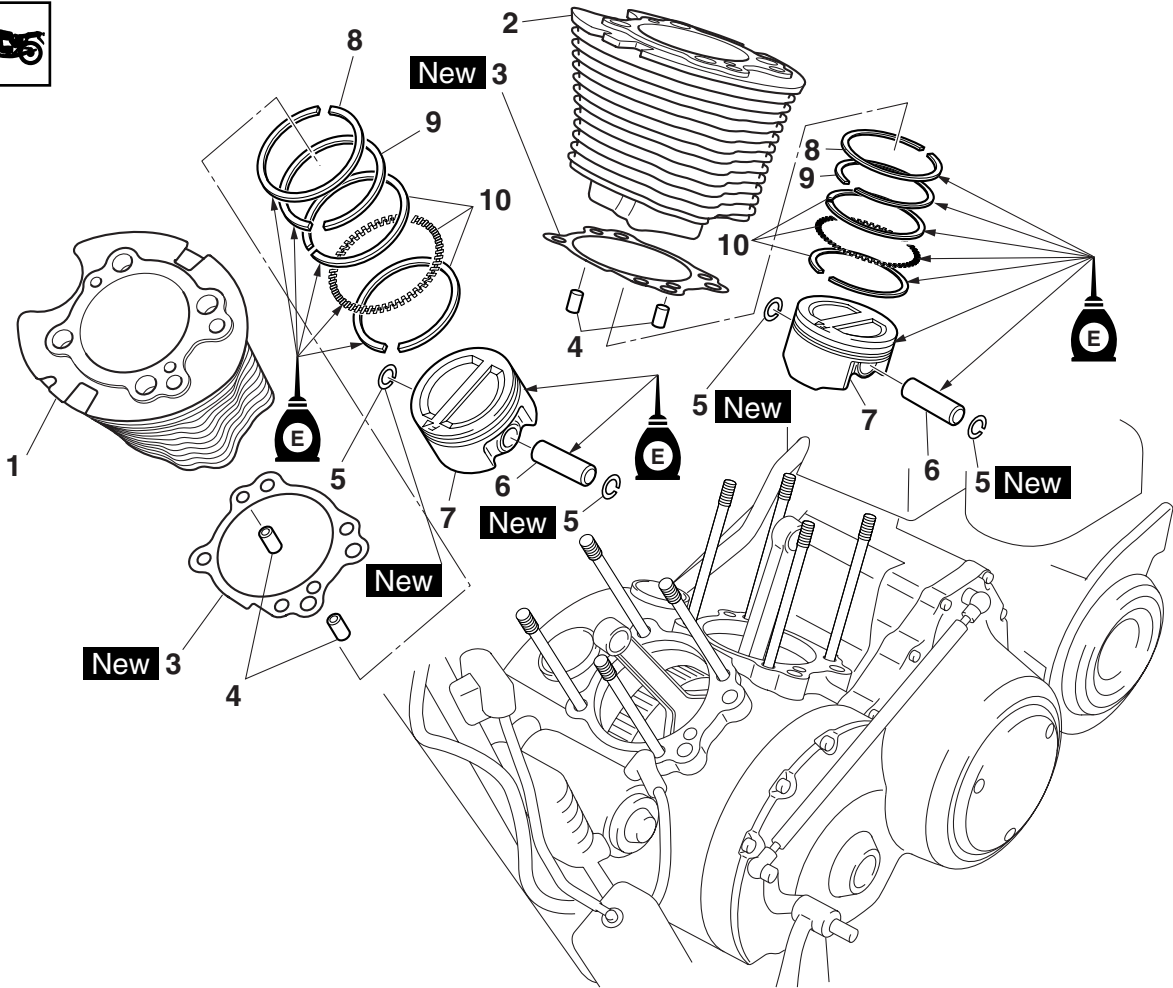

Order	Job/Parts to remove	Q'ty	Remarks
	Cylinder heads		Refer to "CYLINDER HEADS" on page 5-36.
1	Front cylinder	1	
2	Rear cylinder	1	
3	Cylinder gasket	2	
4	Dowel pin	4	
5	Circlip	4	
6	Piston pin	2	
7	Piston	2	
8	Top ring	2	
9	2nd ring	2	
10	Oil ring	2	
			For installation, reverse the removal procedure.

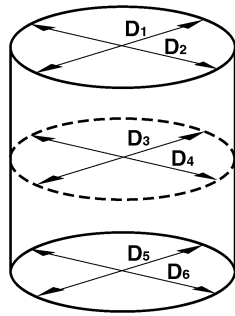

- b. If out of specification, rebore or replace the cylinder, and replace the piston and piston rings as a set.
- c. Measure piston skirt diameter D "a" with the micrometer.

Piston Diameter D
99.960–99.975 mm (3.9354–3.9360 in)

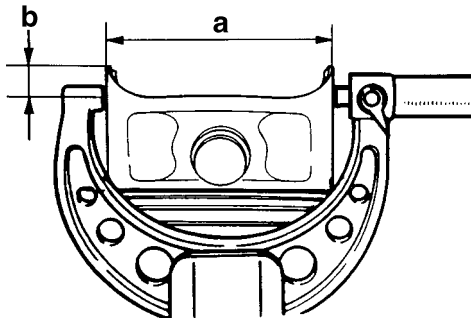

- b. 10 mm (0.39 in) from the bottom edge of the piston
- d. If out of specification, replace the piston and piston rings as a set.
- e. Calculate the piston-to-cylinder clearance with the following formula.

- Piston-to-cylinder clearance =
 Cylinder bore "C" -
 Piston skirt diameter "D"

Piston-to-cylinder clearance
0.025–0.050 mm (0.0010–0.0020 in)
Limit
0.15 mm (0.0059 in)

- f. If out of specification, rebore or replace the cylinder, and replace the piston and piston rings as a set.



EAS24430

CHECKING THE PISTON RINGS

1. Measure:
 - Piston ring side clearance
 Out of specification → Replace the piston and piston rings as a set.

NOTE:

Before measuring the piston ring side clearance, eliminate any carbon deposits from the piston ring grooves and piston rings.



Piston ring

Top ring
Ring side clearance
0.030–0.080 mm (0.0012–0.0032 in)
Limit
0.120 mm (0.0047 in)

2nd ring
Ring side clearance
0.030–0.070 mm (0.0012–0.0028 in)
Limit
0.120 mm (0.0047 in)

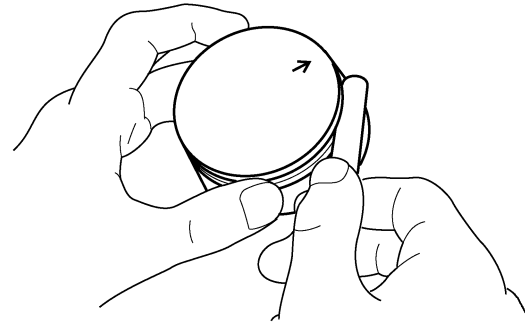

2. Install:
 - Piston ring
 (into the cylinder)

NOTE:

Level the piston ring into the cylinder with the piston crown.

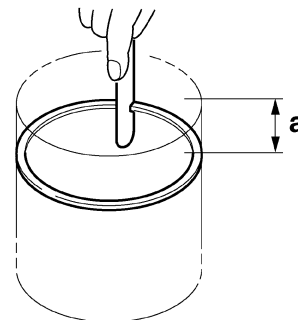

- a. 10 mm (0.39 in)

3. Measure:

- Piston ring end gap
Out of specification → Replace the piston ring.

NOTE:

The oil ring expander spacer's end gap cannot be measured. If the oil ring rail's gap is excessive, replace all three piston rings.

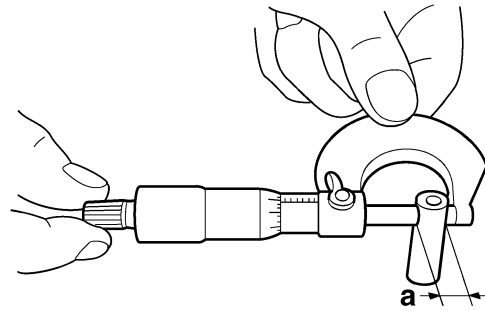

Piston ring

Top ring

End gap (installed)
0.20–0.35 mm (0.0079–0.0138 in)

Limit
0.55 mm (0.0217 in)

2nd ring

End gap (installed)
0.45–0.60 mm (0.0177–0.0236 in)

Limit
0.95 mm (0.0374 in)

Oil ring

End gap (installed)
0.20–0.70 mm (0.0079–0.0276 in)

3. Measure:

- Piston pin bore diameter “b”
Out of specification → Replace the piston.



Piston pin bore inside diameter
23.004–23.015 mm (0.9057–0.9061 in)

Limit
23.045 mm (0.9073 in)

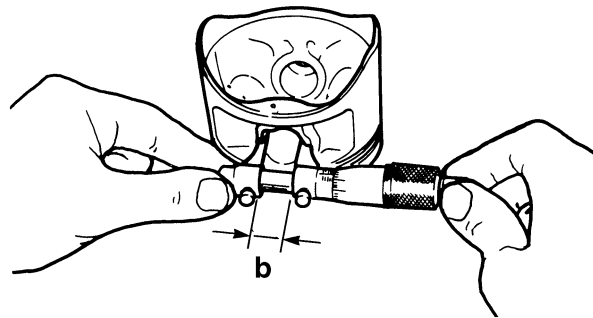

EAS24440

CHECKING THE PISTON PINS

The following procedure applies to all of the piston pins.

1. Check:

- Piston pin
Blue discoloration/grooves → Replace the piston pin and then check the lubrication system.

2. Measure:

- Piston pin outside diameter “a”
Out of specification → Replace the piston pin.



Piston pin outside diameter
22.991–23.000 mm (0.9052–0.9055 in)

Limit
22.971 mm (0.9044 in)

4. Calculate:

- Piston-pin-to-piston-pin-bore clearance
Out of specification → Replace the piston pin and piston as a set.

• Piston-pin-to-piston-pin-bore clearance =
Piston pin bore diameter “b” -
Piston pin outside diameter “a”



Piston-pin-to-piston-pin-bore clearance
0.004–0.024 mm (0.00016–0.00094 in)

EAS24460

INSTALLING THE PISTONS AND CYLINDERS

The following procedure applies to all of the pistons and cylinders.

1. Install:

- Top ring “1”
- 2nd ring “2”
- Lower oil ring rail “3”
- Upper oil ring rail “4”
- Oil ring expander “5”

CYLINDERS AND PISTONS

NOTE:

Be sure to install the piston rings so that the manufacturer's marks or numbers face up.

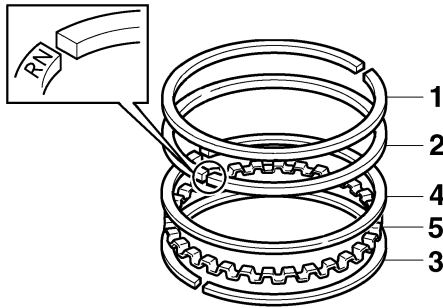

2. Install:

- Piston "1"
- Piston pin "2"
- Piston pin clips "3" **New**

NOTE:

- Apply engine oil onto the piston pin.
- Make sure the arrow mark "a" on the piston faces towards the front of the vehicle.
- Before installing the piston pin clips, cover the crankcase opening with a clean rag to prevent the clip from falling into the crankcase.
- Install the piston pin clips, so that the clip ends are 3 mm (0.12 in) "b" or more from the cutout in the piston.
- Reinstall each piston into its original cylinder (numbering order starting from the left: #1 to #2).

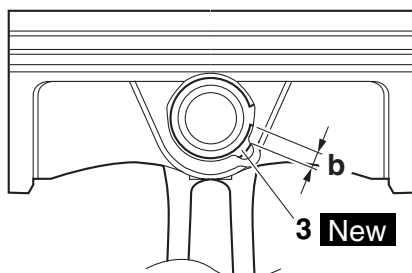
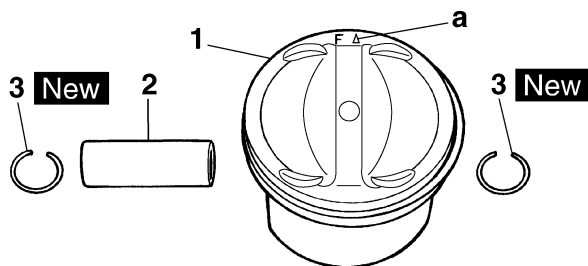

3. Lubricate:

- Piston
- Piston rings
- Cylinder
(with the recommended lubricant)



4. Offset:

- Piston ring end gaps

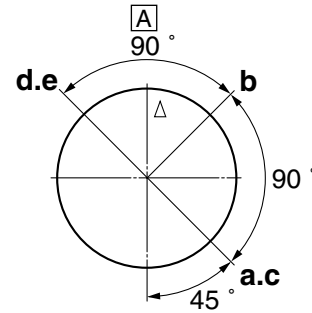

- a. Top ring
- b. Upper oil ring rail
- c. Oil ring expander
- d. Lower oil ring rail
- e. 2nd ring
- A. forward

5. Install:

- Cylinder "1"

NOTE:

While compressing the piston rings with one hand, install the cylinder with the other hand.

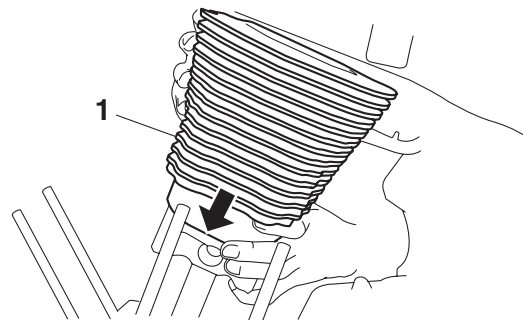

EAS25060

CLUTCH

Removing the clutch cover

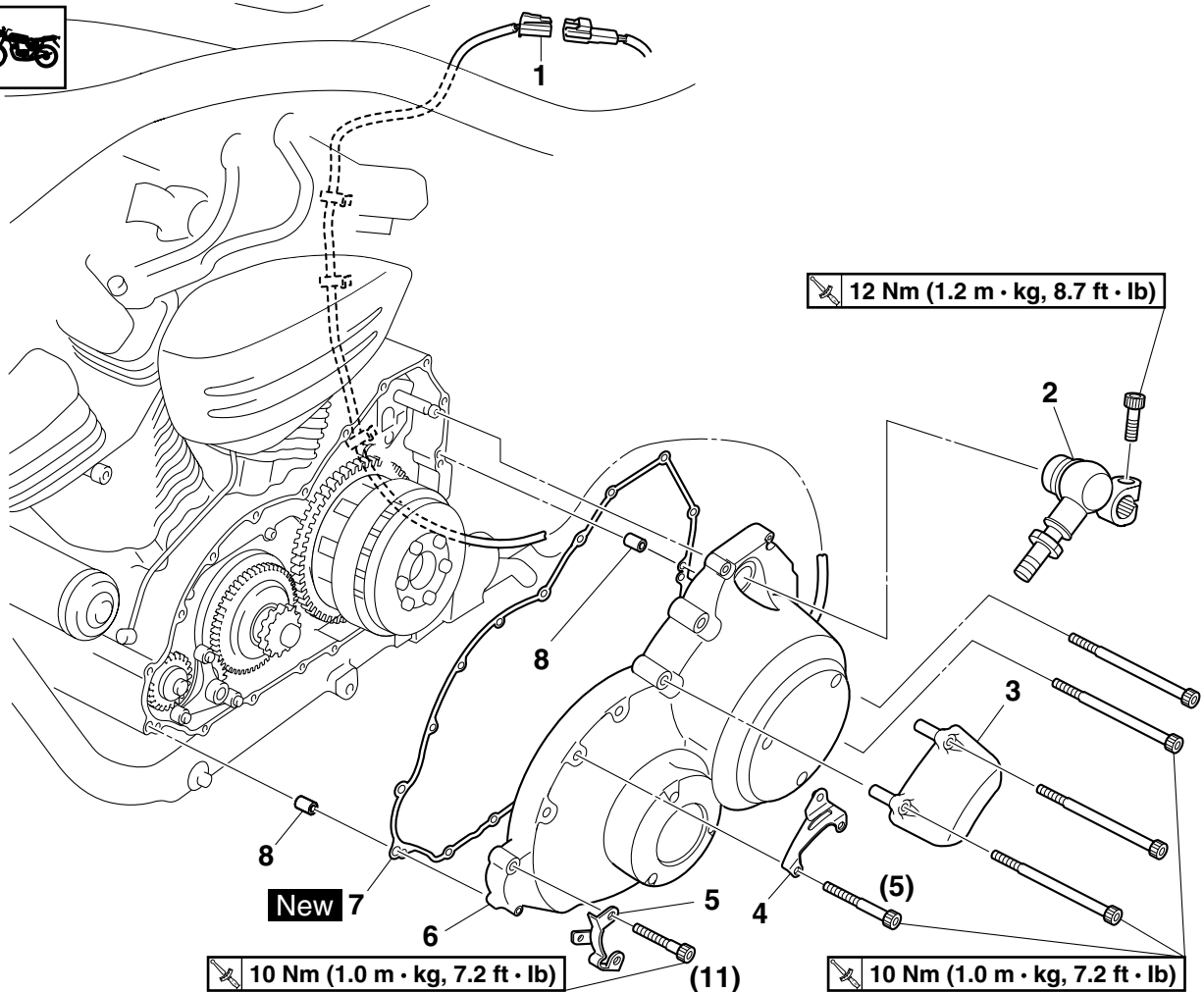

Order	Job/Parts to remove	Q'ty	Remarks
	Engine oil		Drain. Refer to "CHANGING THE ENGINE OIL" on page 3-11.
	Left side cover		Refer to "GENERAL CHASSIS" on page 4-1.
	Horn 1/Canister		Refer to "THROTTLE BODIES" on page 6-7. For California only
	Fuel tank/Sub-fuel tank		Refer to "FUEL TANK" on page 6-1.
	Left rider footrest assembly/Shift rod/Sidestand		Refer to "ENGINE REMOVAL" on page 5-1.
	Generator cover		Refer to "GENERATOR AND STARTER CLUTCH" on page 5-77.
	Drive pulley case		Refer to "TRANSFER GEAR CASE" on page 5-86.
1	Crankshaft position sensor coupler	1	Disconnect.
2	Shift arm	1	
3	Protector	1	For XV19CS(C)/ XV19C(C)
4	Fuel tank breather/overflow pipe bracket	1	For XV19CS(C)/ XV19C(C)
5	Fuel tank breather/overflow pipe holder bracket	1	For USA only For XV19CS(C)/ XV19C(C)

Removing the clutch cover

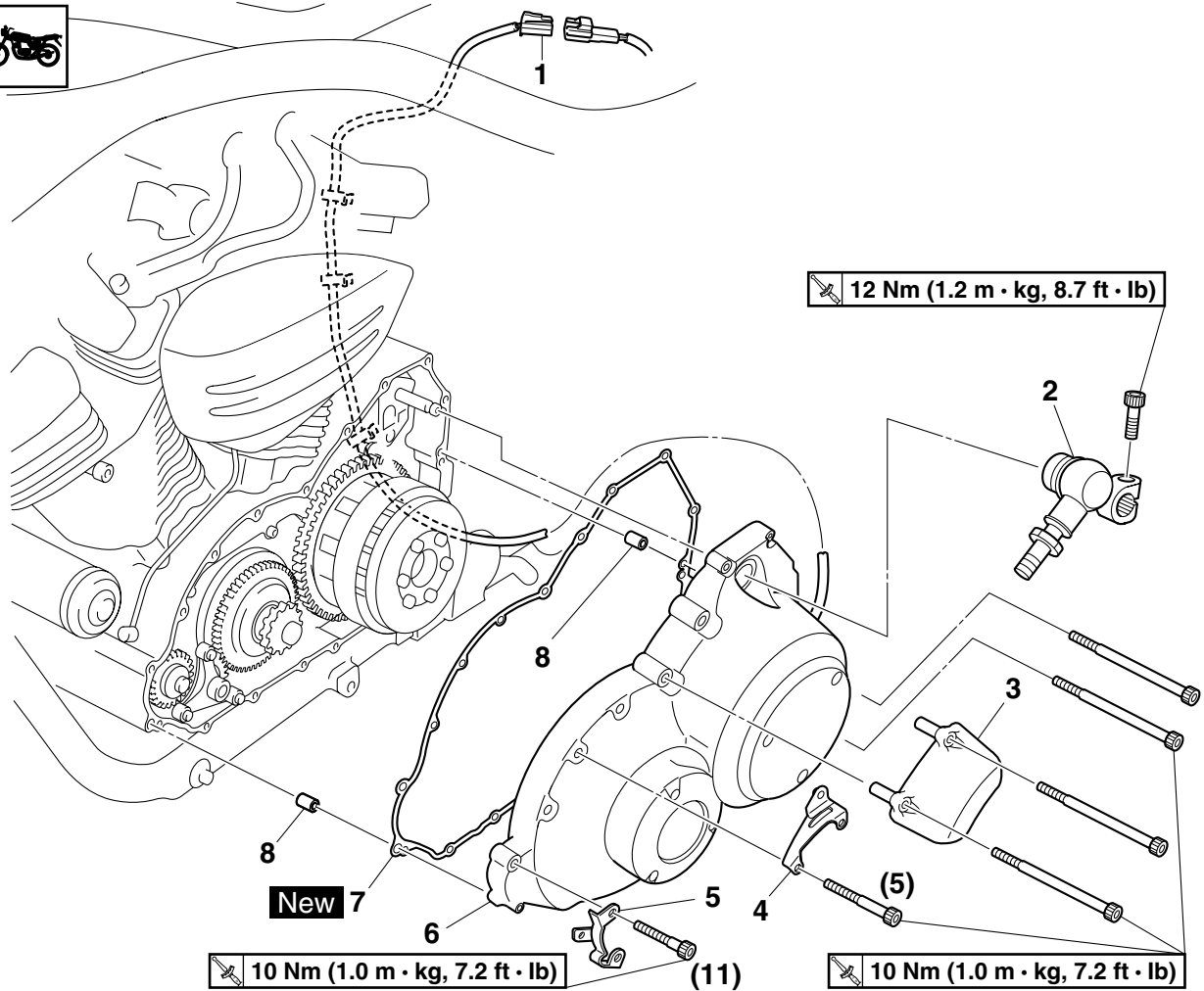

Order	Job/Parts to remove	Q'ty	Remarks
6	Clutch cover	1	
7	Clutch cover gasket	1	
8	Dowel pin	2	
			For installation, reverse the removal procedure.

Removing the crankshaft position sensor

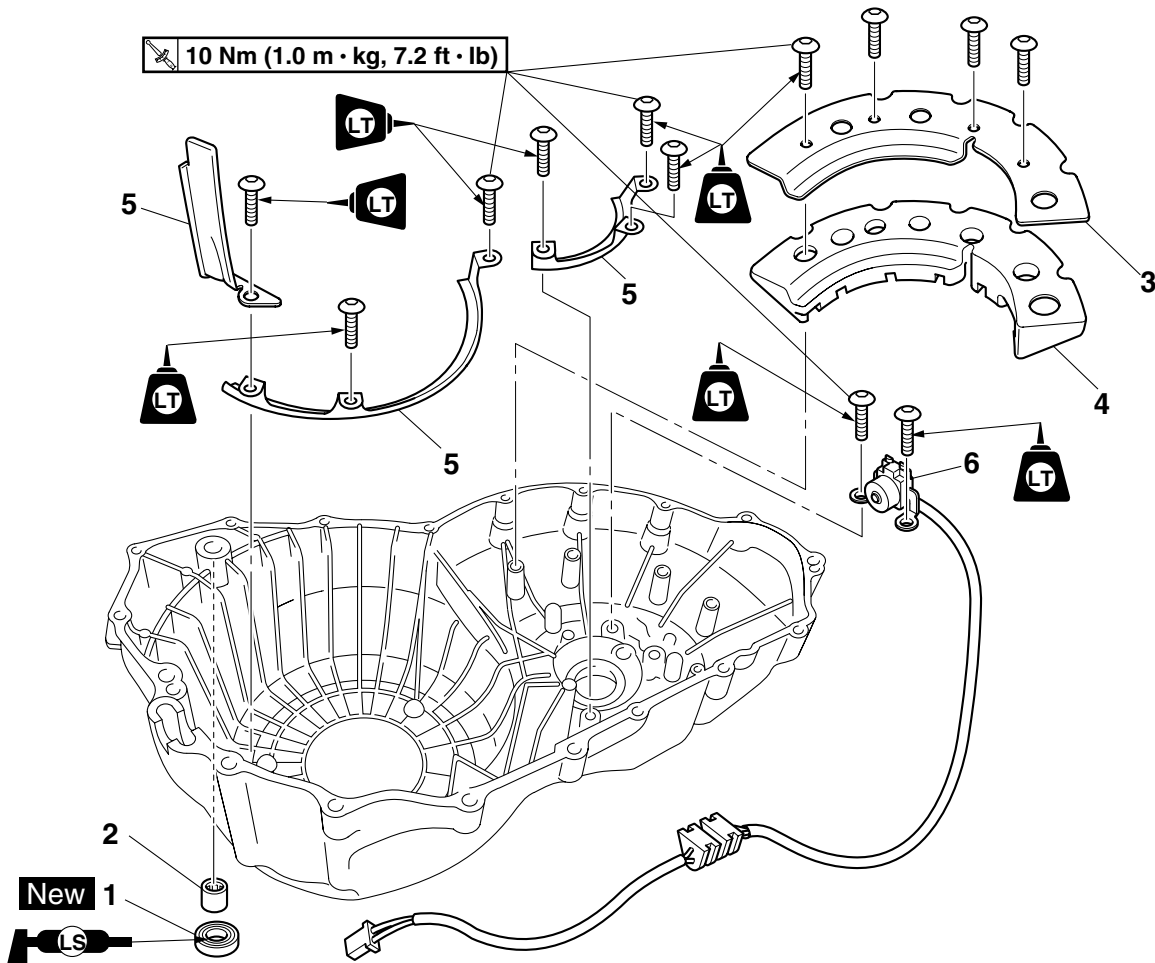

Order	Job/Parts to remove	Q'ty	Remarks
1	Oil seal	1	
2	Bearing	1	
3	Clutch cover damper plate	1	
4	Clutch cover damper	1	
5	Crankshaft position sensor lead holder	3	
6	Crankshaft position sensor	1	
			For installation, reverse the removal procedure.

Removing the clutch

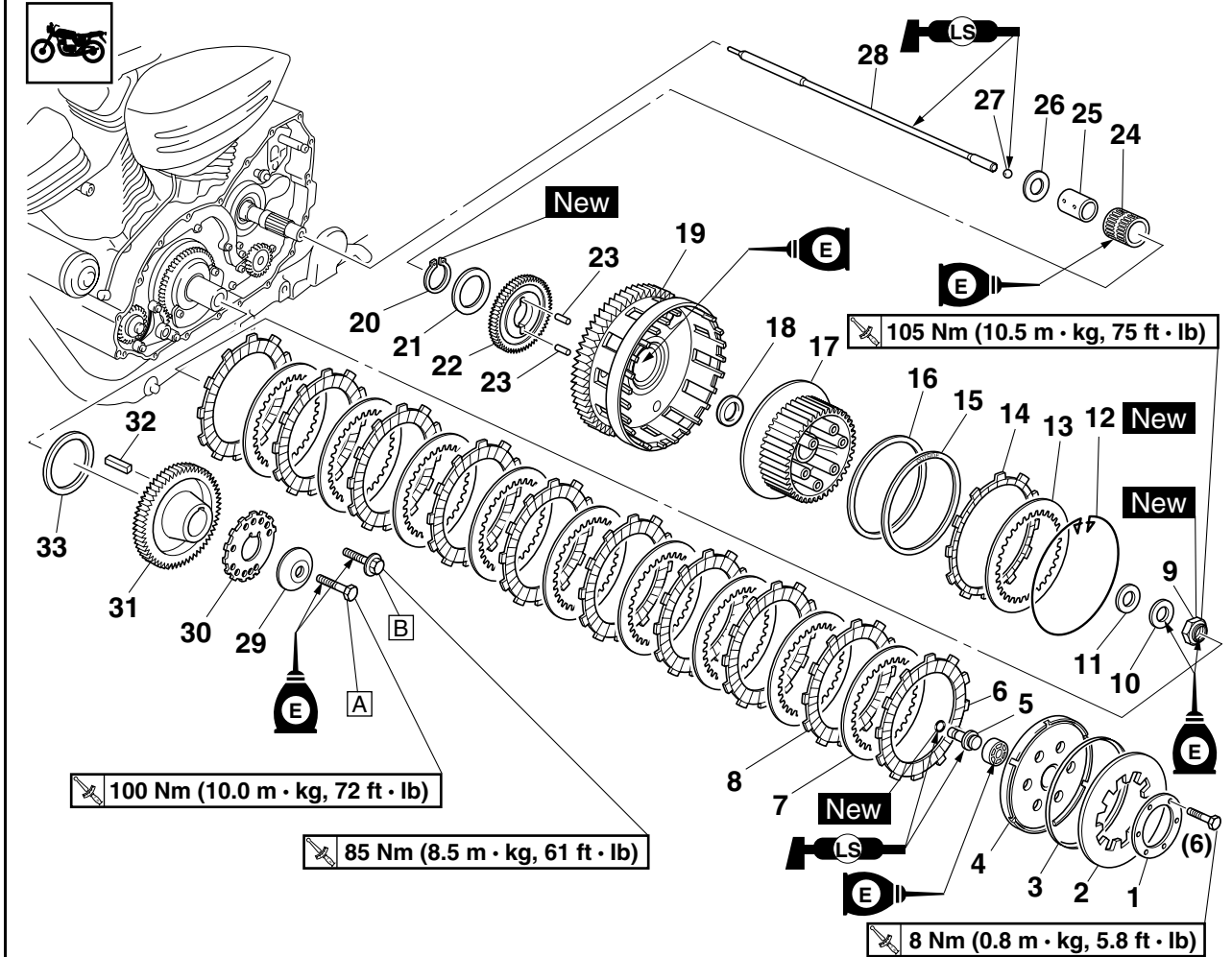

Order	Job/Parts to remove	Q'ty	Remarks
1	Clutch spring plate retainer	1	
2	Clutch spring plate	1	
3	Clutch spring plate seat	1	
4	Pressure plate	1	
5	Short clutch push rod	1	
6	Friction plate 1	1	Inside diameter: 124 mm (4.88 in)
7	Clutch plate	9	
8	Friction plate 2	9	
9	Clutch boss nut	1	
10	Conical spring washer	1	
11	Washer	1	
12	Wire circlip	1	
13	Clutch plate	1	
14	Friction plate 3	1	Inside diameter: 135 mm (5.31 in)
15	Clutch damper spring	1	
16	Clutch damper spring seat	1	
17	Clutch boss	1	

Removing the clutch

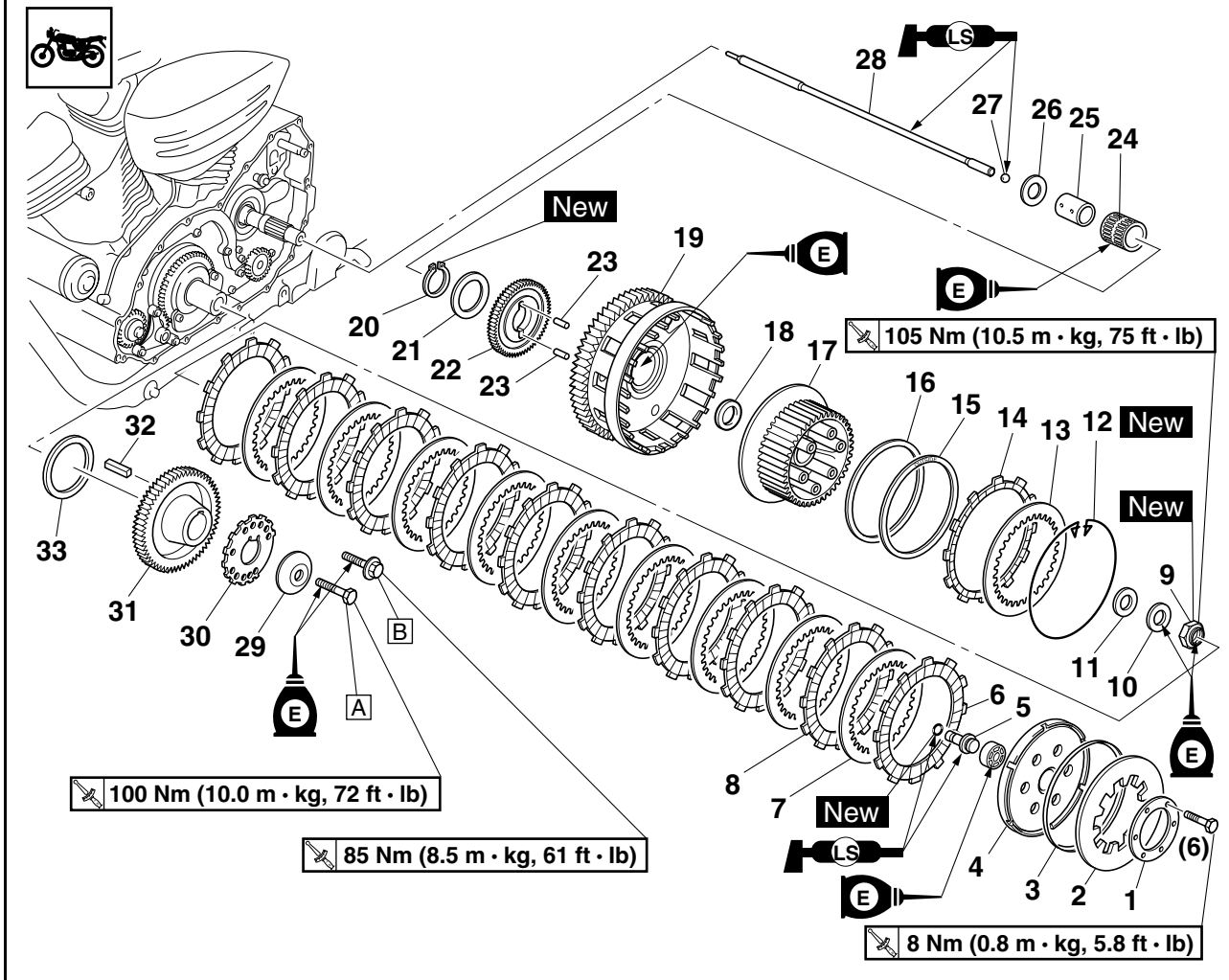

Order	Job/Parts to remove	Q'ty	Remarks
18	Thrust washer 1	1	
19	Clutch housing	1	
20	Circlip	1	
21	Washer	1	
22	Oil pump drive gear	1	
23	Dowel pin	2	
24	Bearing	1	
25	Collar	1	
26	Thrust washer 2	1	
27	Ball	1	
28	Long push rod	1	
29	Spacer	1	
30	Crankshaft position sensor rotor	1	
31	Primary drive gear	1	
32	Straight key	1	

Removing the clutch

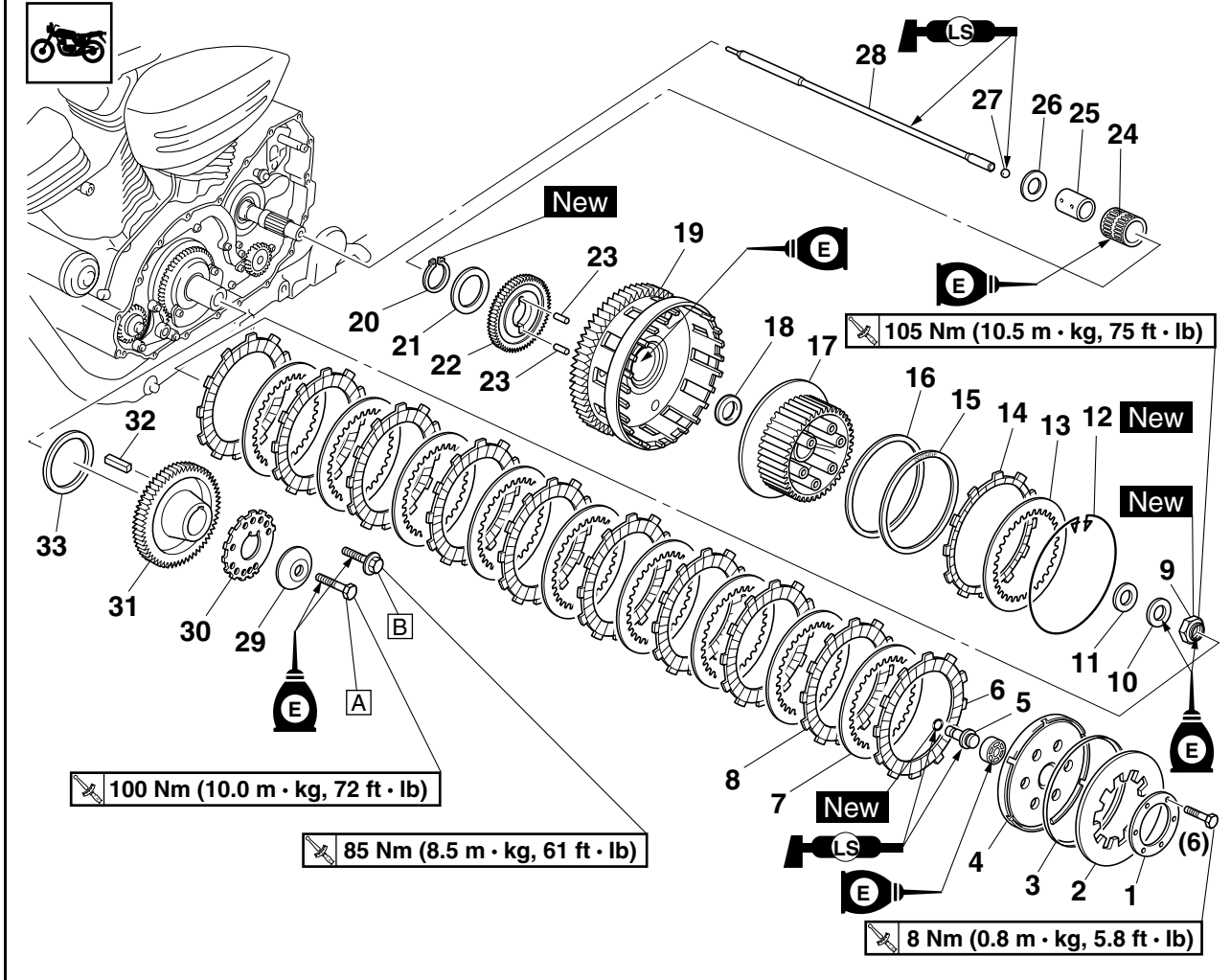

Order	Job/Parts to remove	Q'ty	Remarks
33	Washer	1	
			For installation, reverse the removal procedure.

A: For XV19S(C)/ XV19M(C)/ XV19CTS(C)/ XV19CTM(C)

B: For XV19CS(C)/ XV19C(C)

Removing the left balancer

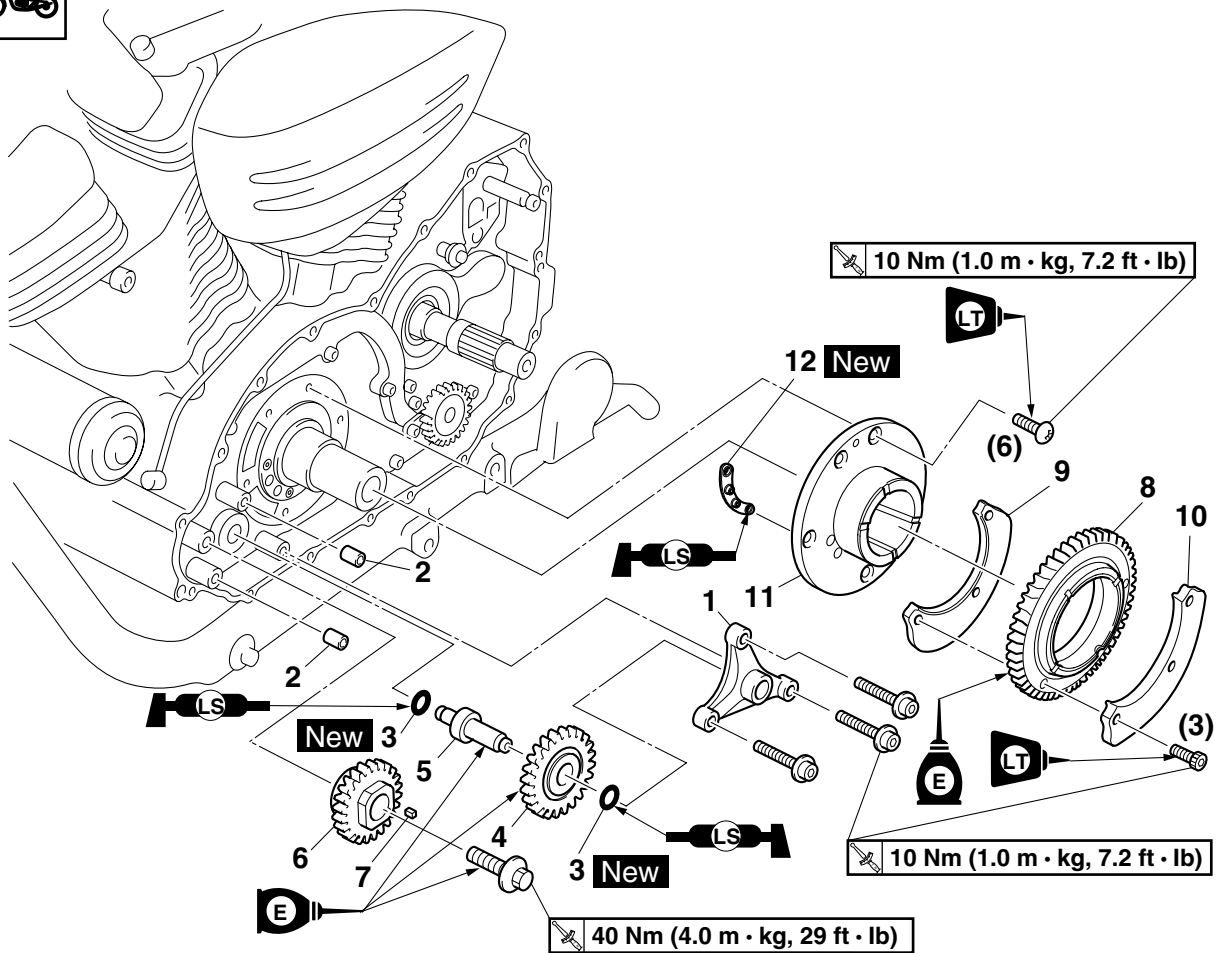

Order	Job/Parts to remove	Q'ty	Remarks
1	Left balancer idle gear shaft holder	1	
2	Dowel pin	2	
3	O-ring	2	
4	Left balancer idle gear	1	
5	Left balancer idle gear shaft	1	
6	Left balancer drive gear	1	
7	Straight key	1	
8	Left balancer driven gear	1	
9	Left balancer weight 1	1	
10	Left balancer weight 2	1	
11	Left balancer driven gear housing	1	
12	Gasket	1	
			For installation, reverse the removal procedure.

Removing the clutch master cylinder

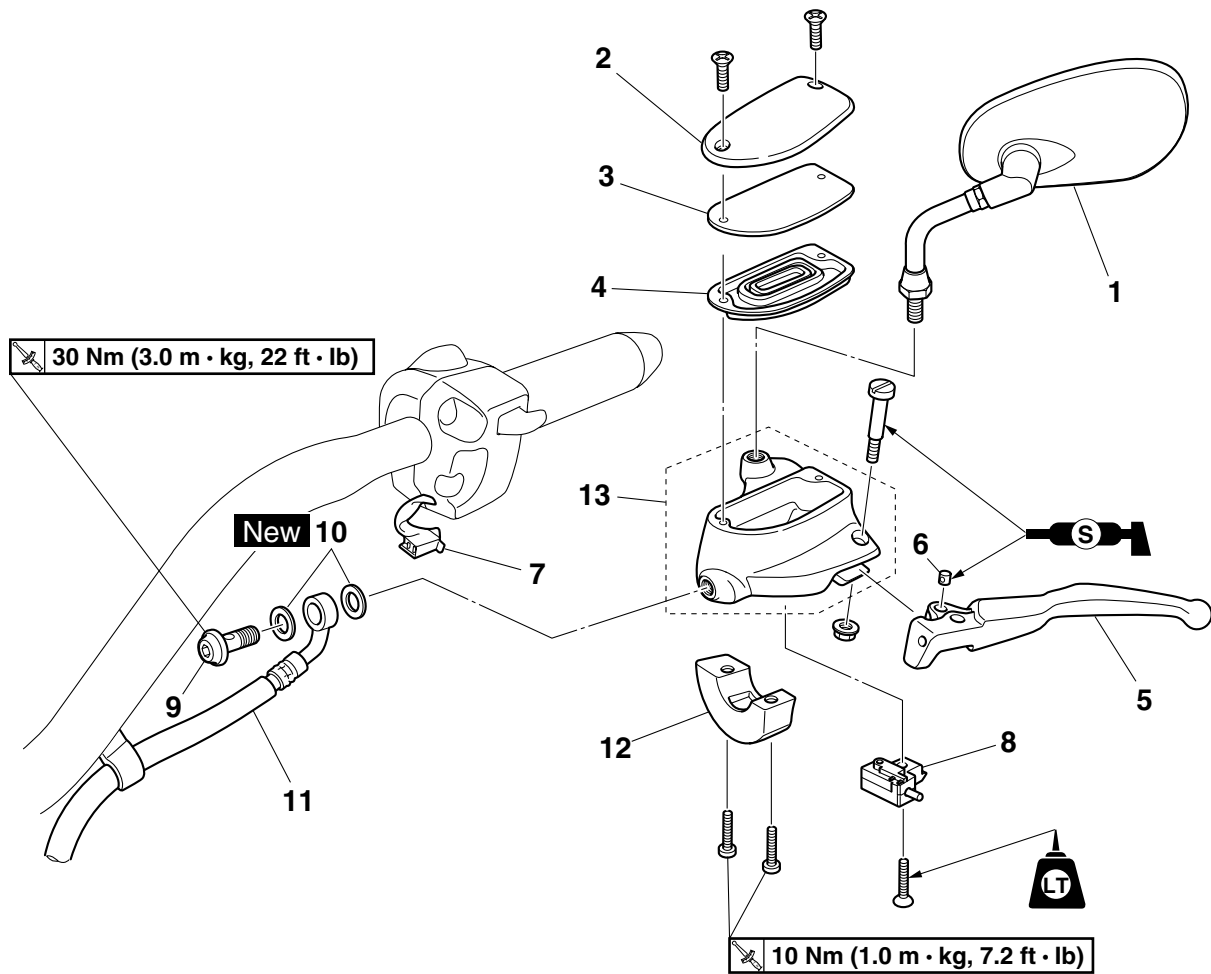

Order	Job/Parts to remove	Q'ty	Remarks
	Clutch fluid		Drain. Refer to "BLEEDING THE HYDRAULIC CLUTCH SYSTEM" on page 3-15.
1	Left rearview mirror	1	
2	Clutch master cylinder reservoir cap	1	
3	Clutch master cylinder reservoir diaphragm holder	1	
4	Clutch master cylinder reservoir diaphragm	1	
5	Clutch lever	1	
6	Clutch master cylinder push rod pin	1	
7	Clutch switch coupler	1	Disconnect.
8	Clutch switch	1	
9	Clutch hose union bolt	1	
10	Copper washer	2	
11	Clutch hose	1	
12	Clutch master cylinder holder	1	
13	Clutch master cylinder	1	
			For installation, reverse the removal procedure.

Disassembling the clutch master cylinder

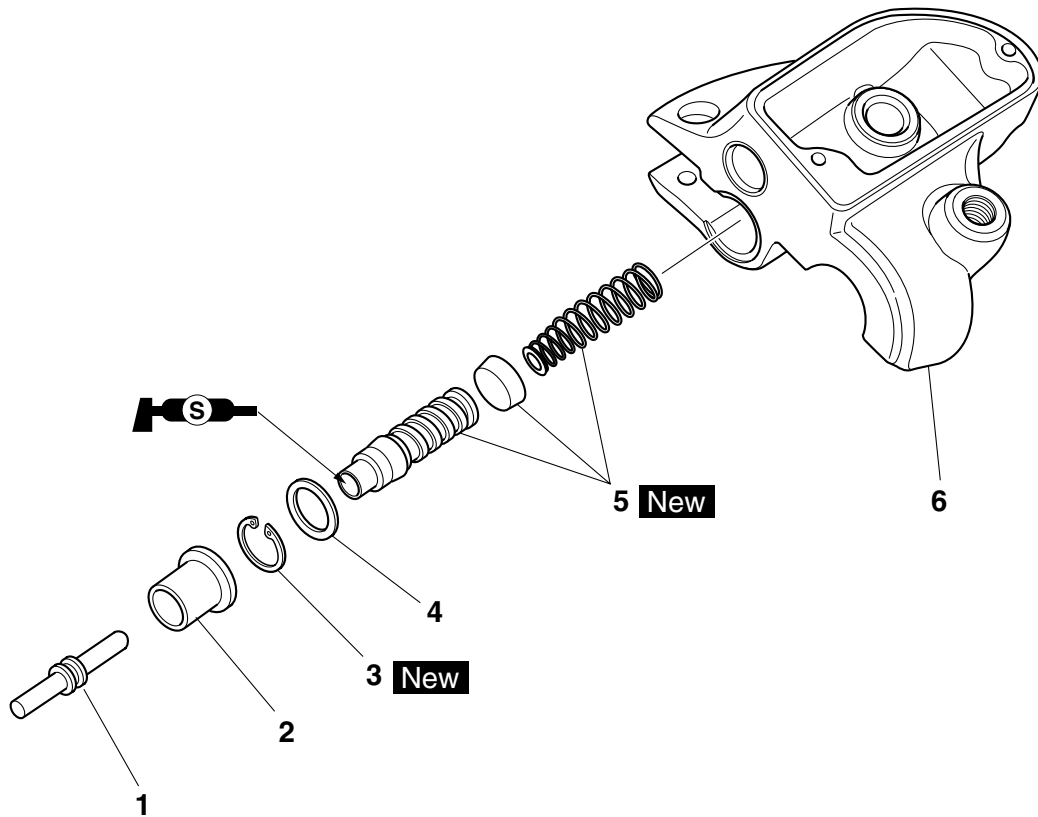

Order	Job/Parts to remove	Q'ty	Remarks
1	Clutch master cylinder push rod	1	
2	Dust boot	1	
3	Circlip	1	
4	Washer	1	
5	Clutch master cylinder kit	1	
6	Clutch master cylinder body	1	
			For assembly, reverse the disassembly procedure.

Removing the clutch release cylinder

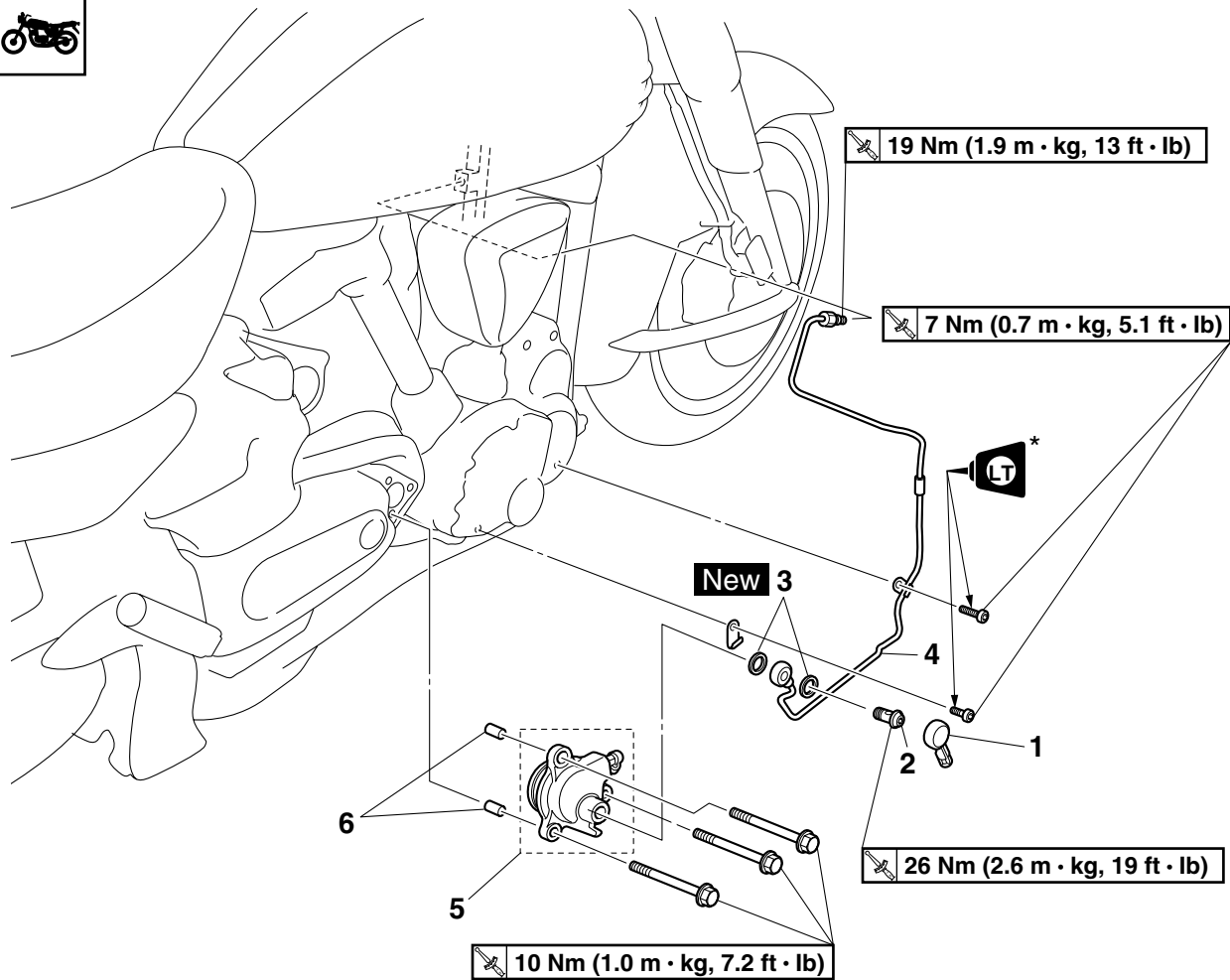

Order	Job/Parts to remove	Q'ty	Remarks
	Clutch fluid		Drain. Refer to "BLEEDING THE HYDRAULIC CLUTCH SYSTEM" on page 3-15.
	Muffler/Exhaust pipes		Refer to "ENGINE REMOVAL" on page 5-1.
1	Clutch pipe union bolt cap	1	
2	Clutch pipe union bolt	1	
3	Copper washer	2	
4	Clutch pipe	1	
5	Clutch release cylinder	1	
6	Dowel pin	2	
			For installation, reverse the removal procedure.

* XV19CS(C)/ XV19C(C)

Disassembling the clutch release cylinder

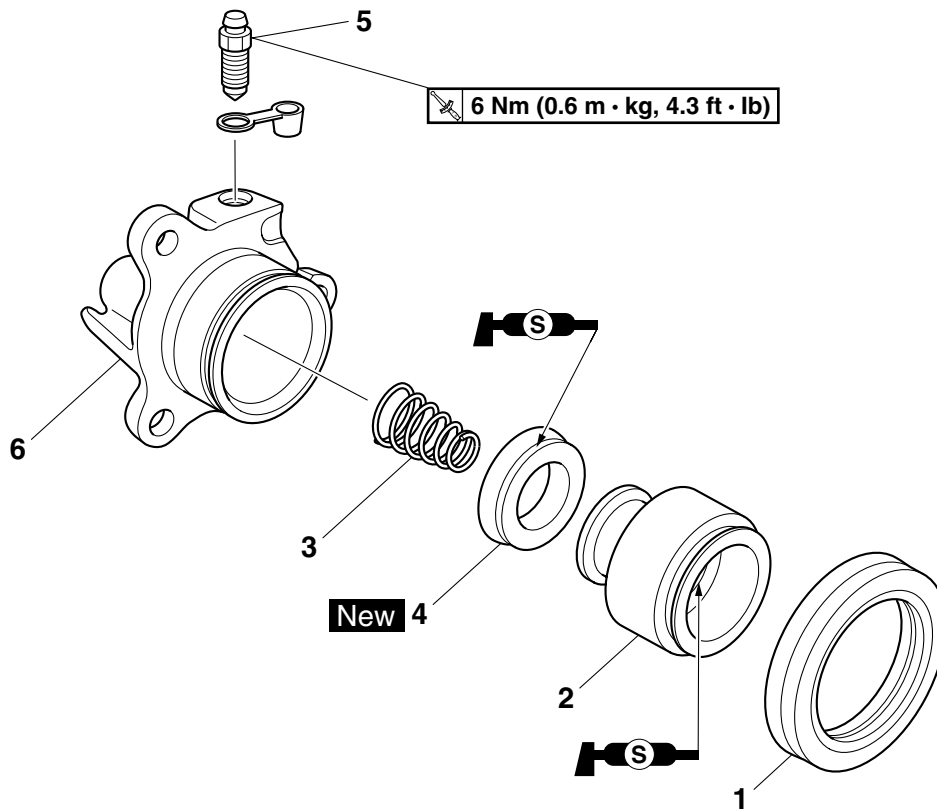

Order	Job/Parts to remove	Q'ty	Remarks
1	Boots	1	
2	Clutch release cylinder piston	1	
3	Clutch release cylinder spring	1	
4	Clutch release cylinder piston seal	1	
5	Bleed screw	1	
6	Clutch release cylinder body	1	
			For assembly, reverse the disassembly procedure.

EAS25080

REMOVING THE CLUTCH

1. Loosen:

- Clutch boss nut "1"

NOTE:

While holding the clutch boss "2" with the universal clutch holder "3", loosen the clutch boss nut.



Universal clutch holder
90890-04086
YM-91042

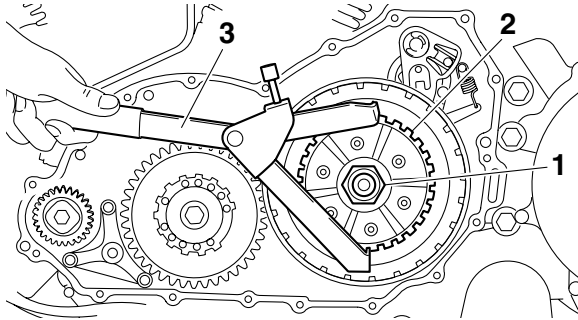

2. Remove:

- Clutch boss nut "1"
- Conical spring washer "2"
- Washer "3"
- Clutch boss assembly "4"

NOTE:

There is a built-in damper between the clutch boss and the clutch plate. It is not necessary to remove the wire circlip "5" and disassemble the built-in damper unless there is serious clutch chattering.

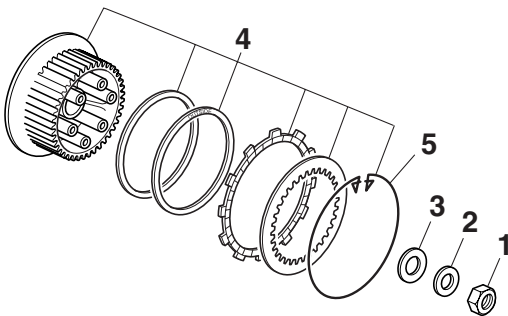

EAS25090

REMOVING THE PRIMARY DRIVE GEAR

1. Loosen:

- Primary drive gear bolt "1"

NOTE:

While holding the generator rotor "2" with the sheave holder "3", loosen the primary drive gear bolt.



Sheave holder
90890-01701
Primary clutch holder
YS-01880-A

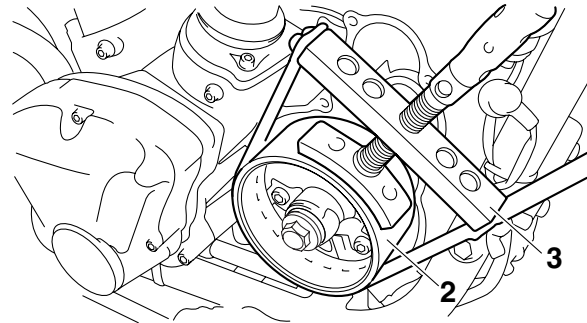
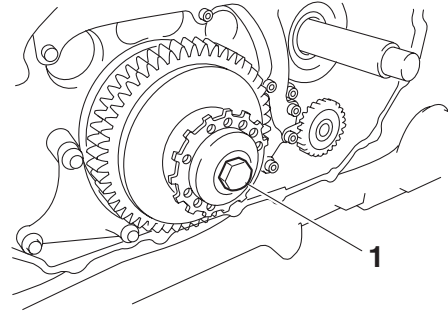

ET1D71021

REMOVING THE LEFT BALANCER DRIVE GEAR

1. Loosen:

- Left balancer drive gear bolt "1"

NOTE:

While the holding the generator rotor "2" with the primary sheave holder "3", loosen the left balancer drive gear bolt.



Sheave holder
90890-01701
Primary clutch holder
YS-01880-A

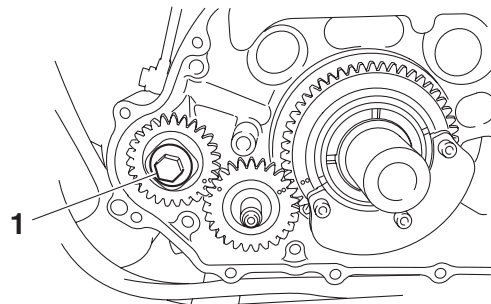

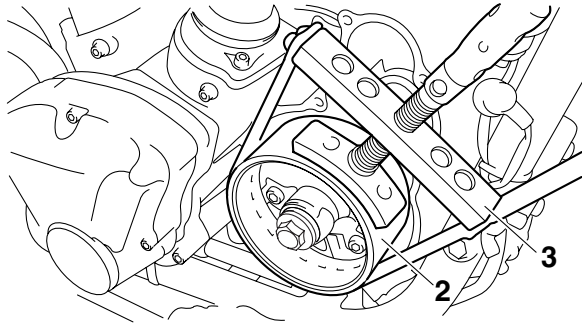

EAS25100

CHECKING THE FRICTION PLATES

The following procedure applies to all of the friction plates.

1. Check:
 - Friction plate
Damage/wear → Replace the friction plates as a set.
2. Measure:
 - Friction plate thickness
Out of specification → Replace the friction plates as a set.

NOTE:

Measure the friction plate at four places.



Friction plate 1, 3 thickness
2.90–3.10 mm (0.114–0.122 in)
Wear limit
2.80 mm (0.110 in)
Friction plate 2 thickness
2.92–3.08 mm (0.115–0.121 in)
Wear limit
2.82 mm (0.111 in)

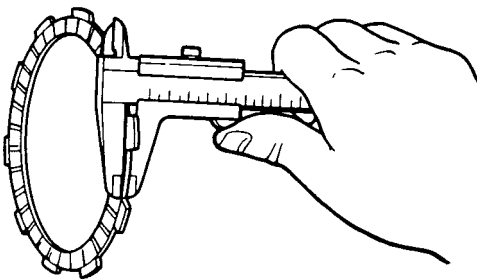

A

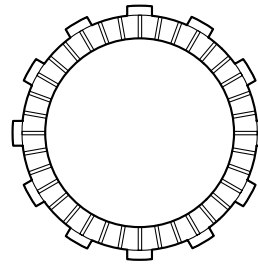

B

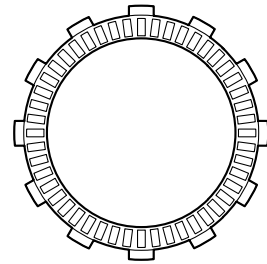

- A. Friction plate 1, 3
- B. Friction plate 2

EAS25110

CHECKING THE CLUTCH PLATES

The following procedure applies to all of the clutch plates.

1. Check:
 - Clutch plate
Damage → Replace the clutch plates as a set.
2. Measure:
 - Clutch plate warpage
(with a surface plate and thickness gauge “1”)
Out of specification → Replace the clutch plates as a set.



Thickness gauge
90890-03180
Feeler gauge set
YU-26900-9



Clutch plate thickness
1.90–2.10 mm (0.075–0.083 in)
Warpage limit
0.20 mm (0.0079 in)

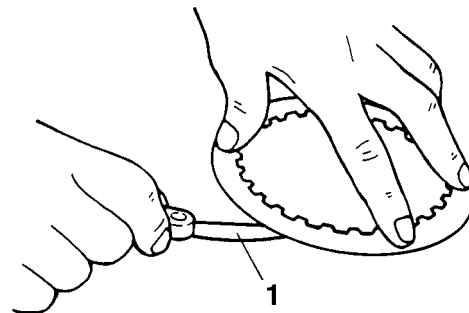

EAS25130

CHECKING THE CLUTCH SPRING PLATE

1. Check:
 - Clutch spring plate
Damage → Replace.

2. Check:

- Clutch spring plate seat
Damage → Replace.

EAS25150

CHECKING THE CLUTCH HOUSING

1. Check:

- Clutch housing dogs
Damage/pitting/wear → Deburr the clutch housing dogs or replace the clutch housing.

NOTE:

Pitting on the clutch housing dogs will cause erratic clutch operation.

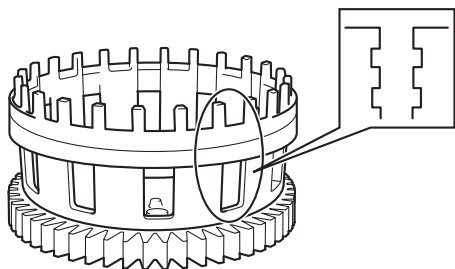

2. Check:

- Bearing
Damage/wear → Replace the bearing and clutch housing.

EAS25160

CHECKING THE CLUTCH BOSS

1. Check:

- Clutch boss splines
Damage/pitting/wear → Replace the clutch boss.

NOTE:

Pitting on the clutch boss splines will cause erratic clutch operation.

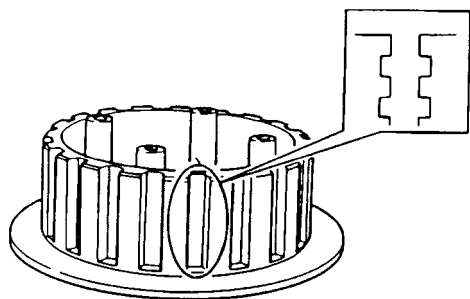

EAS25170

CHECKING THE PRESSURE PLATE

1. Check:

- Pressure plate
Cracks/damage → Replace.

- Bearing
Damage/wear → Replace.

EAS25190

CHECKING THE CLUTCH PUSH RODS

1. Check:

- O-ring
- Short clutch push rod
- Long clutch push rod
- Ball
Cracks/damage/wear → Replace the defective part(s).

2. Measure:

- Long clutch push rod bending limit
Out of specification → Replace the defective part(s).



Long clutch push rod bending limit
0.30 mm (0.0118 in)

EAS25200

CHECKING THE PRIMARY DRIVE GEAR

1. Check:

- Primary drive gear
Damage/wear → Replace the primary drive and primary driven gears as a set.
Excessive noise during operation → Replace the primary drive and primary driven gears as a set.

EAS25210

CHECKING THE PRIMARY DRIVEN GEAR

1. Check:

- Primary driven gear "1"
Damage/wear → Replace the primary drive and primary driven gears as a set.
Excessive noise during operation → Replace the primary drive and primary driven gears as a set.

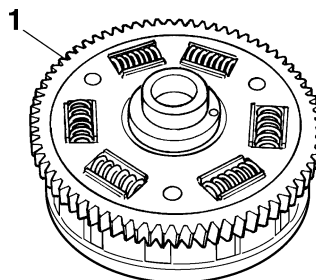

ET1D71033

CHECKING THE LEFT BALANCER GEARS

1. Check:

- Left balancer drive gear
- Left balancer driven gear

- Left balancer idle gear
Burr/chips/roughness/wear → Replace the defective part(s).
2. Measure:
- Left balancer driven gear inside diameter “a”
Out of specification → Replace.



Left balancer driven gear inside diameter “a”
59.010–59.028 mm (2.323–2.324 in)
Limit
59.100 mm (2.327 in)

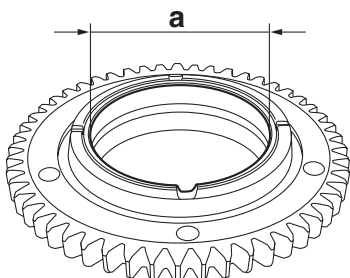

3. Measure:
- Left balancer driven gear housing outside diameter “a”
Out of specification → Replace.



Left balancer driven gear housing outside diameter “a”
58.925–58.960 mm (2.320–2.321 in)
Limit
58.900 mm (2.318 in)

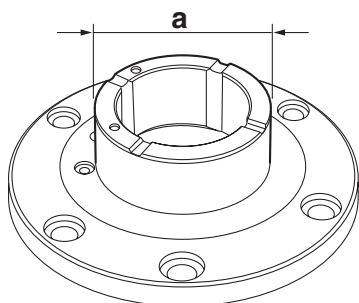

4. Calculate:
- Left-balancer-driven-gear-to-left-balancer-driven-gear-housing clearance
Out of specification → Replace the defective part(s).

NOTE:

Calculate the clearance by subtracting the left balancer driven gear housing outside diameter from the left balancer driven gear inside diameter.



Left-balancer-driven-gear-to-left-balancer-driven-gear-housing clearance
0.050–0.103 mm (0.0020–0.0041 in)

ET1D71022

INSTALLING THE LEFT BALANCER DRIVE GEAR

1. Install:
- Left balancer weight 1 “1”
 - Left balancer weight 2 “2”
 - Left balancer driven gear “3”

NOTE:

Make sure that the punch marks “a” on the left balancer driven gear are facing toward left balancer weight 2.



Left balancer weight bolt
10 Nm (1.0 m·kg, 7.2 ft·lb)
LOCTITE®

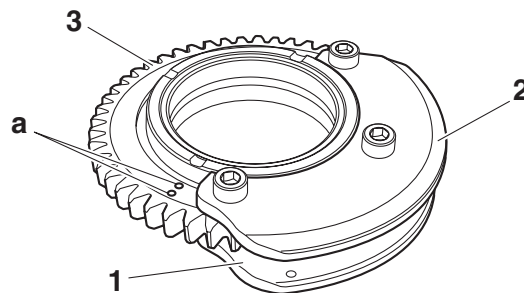

2. Remove:
- Generator rotor
Refer to “REMOVING THE GENERATOR” on page 5-79.
3. Align:
- Mark “a” on the generator drive gear of the crankshaft (with the mark “b” on the generator shaft driven gear)



- a. Turn the crankshaft.
- b. When the front and rear pistons are near TDC, align the mark “a” on the generator drive gear of the crankshaft with the mark “b” on the generator shaft driven gear.

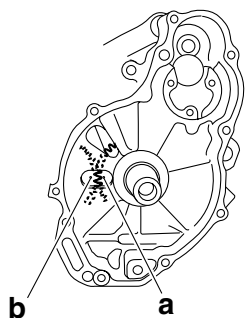

4. Install:

- Generator rotor
Refer to "INSTALLING THE GENERATOR" on page 5-80.

5. Install:

- Left balancer drive gear "1"
- Left balancer idle gear "2"
- Left balancer driven gear "3"

NOTE:

- Align the punch mark "a" on the left balancer drive gear with the punch mark "b" on the left balancer idle gear.
- Align the punch marks "c" on the left balancer idle gear with the punch marks "d" on the left balancer driven gear.

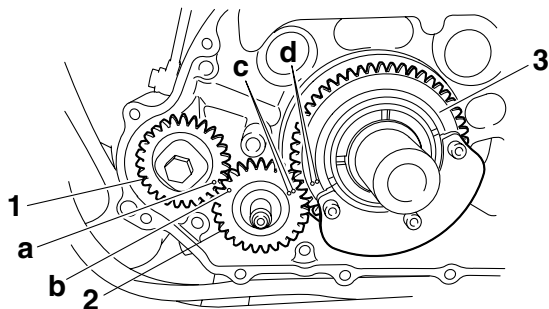

6. Tighten:

- Left balancer drive gear bolt "1"

	Left balancer drive gear bolt 40 Nm (4.0 m·kg, 29 ft·lb)
---	--

NOTE:

While holding the generator rotor "2" with the sheave holder "3", tighten the left balancer drive gear bolt.

	Sheave holder 90890-01701 Primary clutch holder YS-01880-A
---	---

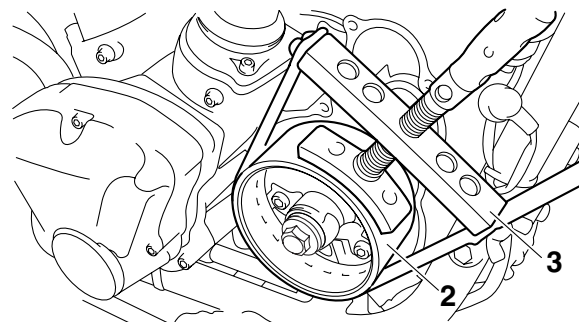
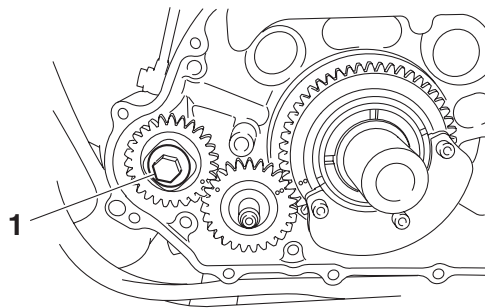

EAS25230

INSTALLING THE PRIMARY DRIVE GEAR

1. Install:

- Washer
- Straight key
- Primary drive gear
- Crankshaft position sensor rotor "1"
- Spacer
- Primary drive gear bolt "2"



Primary drive gear bolt
100 Nm (10.0 m·kg, 72 ft·lb)

EC1D71007

CAUTION:

The timing marks on the crankshaft position sensor rotor must face outside.

NOTE:

- Lubricate the primary drive gear bolt threads with engine oil.
- While holding the generator rotor "3" with the sheave holder "4", tighten the primary drive gear bolt.



Sheave holder
90890-01701
Primary clutch holder
YS-01880-A

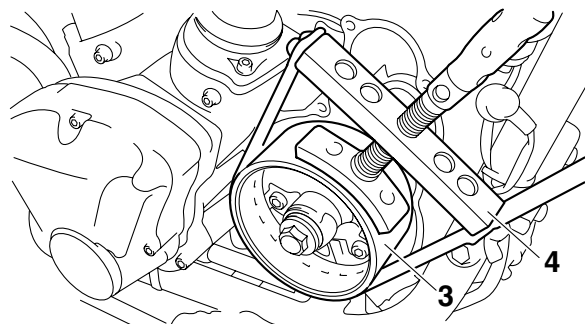
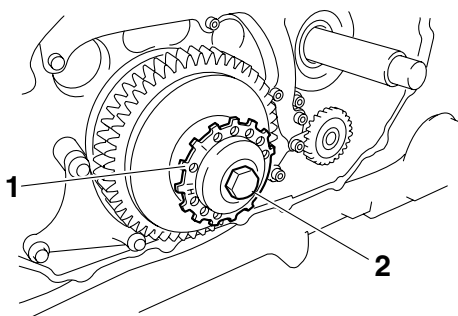

EAS25260

INSTALLING THE CLUTCH

1. Install:

- Clutch housing
- Thrust washer

NOTE:

- Lubricate the clutch housing bearings with engine oil.
- Make sure that the primary driven gear teeth and primary drive gear teeth mesh correctly.
- Make sure that the primary driven gear teeth and oil pump driven gear teeth mesh correctly.

2. Install:

- Clutch boss assembly "1"

NOTE:

- Install the clutch damper spring "2" with the "OUTSIDE" mark facing out.
- If the wire circlip "3" has been removed, carefully install a new one.

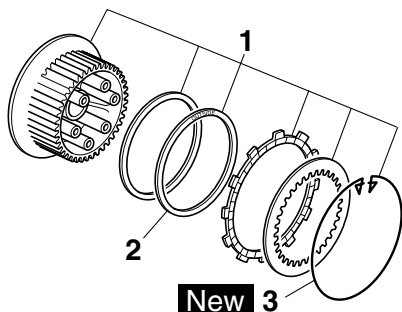

3. Install:

- Clutch boss "1"

- Washer
- Conical spring washer "2"
- Clutch boss nut "3"



Clutch boss nut
105 Nm (10.5 m·kg, 75 ft·lb)

NOTE:

- Lubricate the clutch boss nut threads and conical spring washer mating surfaces with engine oil.
- Install the conical spring washer "2" with the "OUT" mark "a" facing out.
- While holding the clutch boss with the universal clutch holder "4", tighten the clutch boss nut.
- Stake the clutch boss nut "3" at a cutout "b" in the main axle.



Universal clutch holder
90890-04086
YM-91042

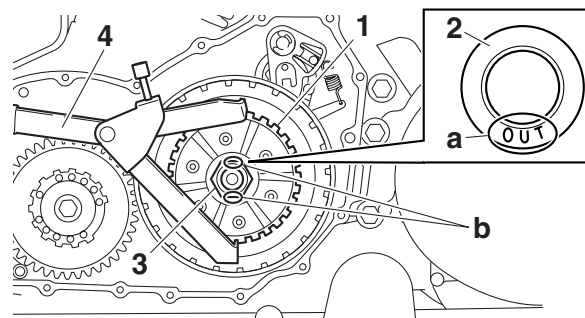

4. Lubricate:

- Friction plates
- Clutch plates
- (with the recommended lubricant)



Recommended lubricant
Engine oil

5. Install:

- Friction plates 2 "1"
- Clutch plates
- Friction plate 1 "2"

NOTE:

- First, install a friction plate and then alternate between a clutch plate and a friction plate.
- Align a projection on each friction plate 2 "1" with the "△" mark "a" on the clutch housing and align a projection on friction plate 1 "2" with the punch mark "b" on the housing.

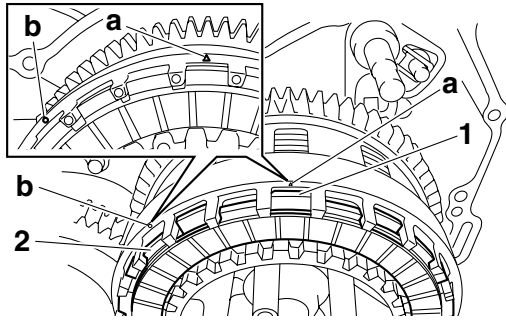

6. Install:

- Clutch spring plate
- Clutch spring plate retainer

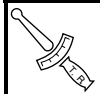

Clutch spring plate retainer bolt
8 Nm (0.8 m·kg, 5.8 ft·lb)

NOTE:

Tighten the clutch spring plate retainer bolts in stages and in a crisscross pattern.

7. Apply:

- Sealant
 (onto the crankshaft position sensor lead grommet)



Yamaha bond No. 1215
90890-85505
(Three Bond No.1215®)

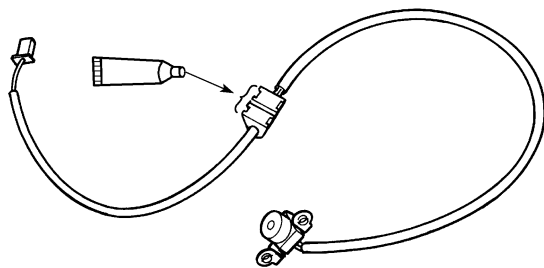

8. Install:

- Shift arm "1"



Shift arm bolt
12 Nm (1.2 m·kg, 8.7 ft·lb)

NOTE:

Install the shift arm "1" with its slot "a" aligned with the mark "b" in end of the shift shaft.

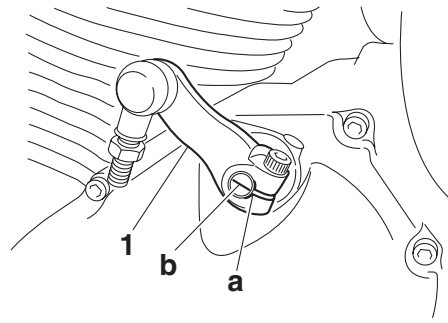

EAS25280

DISASSEMBLING THE CLUTCH MASTER CYLINDER

NOTE:

Before disassembling the clutch master cylinder, drain the clutch fluid from the entire clutch system.

1. Remove:

- Clutch hose union bolt "1"
- Copper washers "2"
- Clutch hose "3"

NOTE:

To collect any remaining clutch fluid, place a container under the master cylinder and the end of the clutch hose.

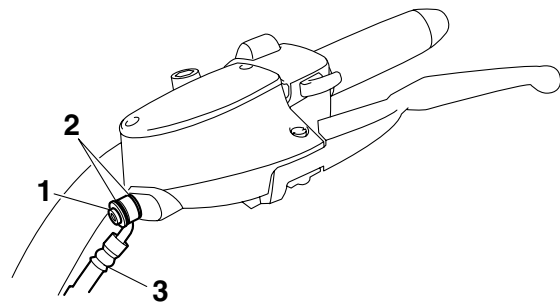

ET1D71037

CHECKING THE CLUTCH MASTER CYLINDER

1. Check:

- Clutch master cylinder
 Damage/scratches/wear → Replace.
- Clutch fluid delivery passage
 (clutch master cylinder body)
 Obstruction → Blow out with compressed air.

2. Check:

- Clutch master cylinder kit
 Damage/scratches/wear → Replace.

3. Check:

- Clutch master cylinder reservoir
 Cracks/damage → Replace.

- Clutch master cylinder reservoir diaphragm
Damage/wear → Replace.
4. Check:
- Clutch hose
Cracks/damage/wear → Replace.

EAS25300

ASSEMBLING THE CLUTCH MASTER CYLINDER

EW1D71010

WARNING

- Before installation, all internal clutch components must be cleaned and lubricated with clean or new clutch fluid.
- Never use solvents on internal clutch components.



Recommended clutch fluid
Brake fluid DOT 4

EAS25310

INSTALLING THE CLUTCH MASTER CYLINDER

1. Install:

- Clutch master cylinder “1”
- Clutch master cylinder holder “2”



Clutch master cylinder holder bolt
10 Nm (1.0 m·kg, 7.2 ft·lb)

NOTE:

- Align the end of the clutch lever holder with the punch mark “a” on the handlebar.
- First, tighten the rear bolt, then the front bolt.

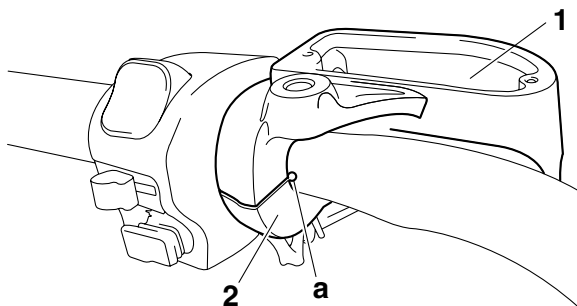

2. Install:

- Copper washers **New**
- Clutch hose “1”
- Clutch hose union bolt “2”



Clutch hose union bolt
30 Nm (3.0 m·kg, 22 ft·lb)

EWA1D77010

WARNING

Proper clutch hose routing is essential to insure safe vehicle operation. Refer to “CABLE ROUTING (for XV19S(C)/ XV19M(C)/ XV19CTS(C)/ XV19CTM(C))” on page 2-51 and “CABLE ROUTING (for XV19CS(C)/ XV19C(C))” on page 2-67.

NOTE:

- Install the clutch hose at a right angle to the clutch master cylinder as shown in the illustration.
- While holding the clutch hose, tighten the union bolt.
- Turn the handlebar to the left and right to make sure the clutch hose does not touch other parts (e.g., wire harness, cables, leads). Correct if necessary.

A

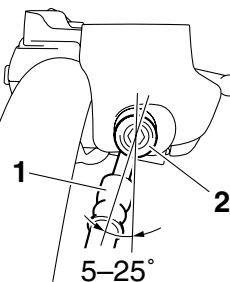

B

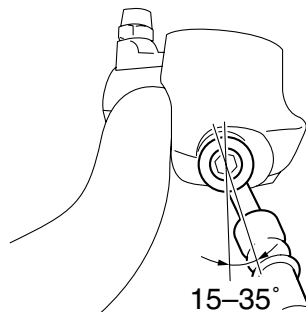

- A. For XV19S(C)/ XV19M(C)/ XV19CTS(C)/ XV19CTM(C)
- B. For XV19CS(C)/ XV19C(C)

3. Fill:

- Clutch master cylinder reservoir
(with the specified amount of the recommended clutch fluid)



Recommended clutch fluid
Brake fluid DOT 4

EWA13370

WARNING

- Use only the designated clutch fluid. Other clutch fluids may cause the rubber seals to deteriorate, causing leakage and poor clutch performance.
- Refill with the same type of clutch fluid that is already in the system. Mixing clutch fluids may result in a harmful chemical reaction, leading to poor clutch performance.
- When refilling, be careful that water does not enter the clutch fluid reservoir. Water will significantly lower the boiling point of the clutch fluid and could cause vapor lock.

ECA13420

CAUTION:

Clutch fluid may damage painted surfaces or plastic parts. Therefore, always clean up any spill clutch fluid immediately.

NOTE:

In order to ensure a correct reading of the clutch fluid level, make sure the top of the reservoir is horizontal.

4. Bleed:
 - Clutch system
Refer to "BLEEDING THE HYDRAULIC CLUTCH SYSTEM" on page 3-15.
5. Check:
 - Clutch fluid level
Below the minimum level mark "a" → Add the recommended clutch fluid to the proper level. Refer to "CHECKING THE CLUTCH FLUID LEVEL" on page 3-14.

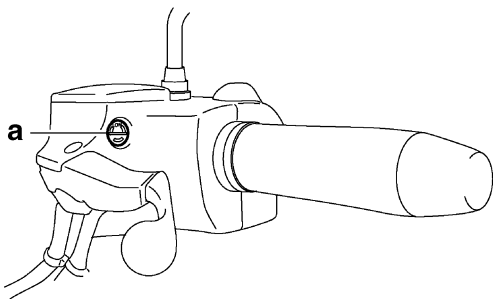

6. Check:
 - Clutch lever operation
Soft or spongy feeling → Bleed the clutch system. Refer to "BLEEDING THE HYDRAULIC CLUTCH SYSTEM" on page 3-15.

ET1D71004

REMOVING THE CLUTCH RELEASE CYLINDER

1. Remove:
 - Clutch pipe union bolt "1"
 - Copper washers "2"
 - Clutch pipe "3"

NOTE:

Put the end of the clutch pipe into a container and pump out the clutch fluid carefully.

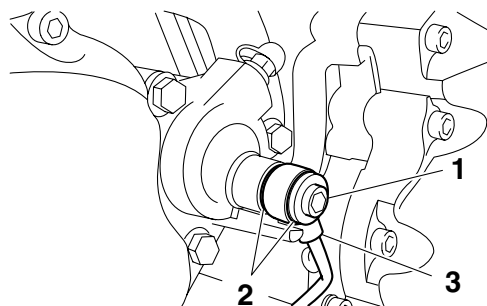

EAS25330

CHECKING THE CLUTCH RELEASE CYLINDER

Recommended clutch component replacement schedule	
Piston seal	Every two years
Clutch hose	Every four years
Clutch fluid	Every two years and whenever the clutch is disassembled

1. Install:
 - Clutch release cylinder body
Cracks/damage → Replace the clutch release cylinder.
2. Check:
 - Clutch release cylinder "1"
 - Clutch release cylinder piston "2"
Rust/scratches/wear → Replace the clutch release cylinder and clutch release cylinder piston as a set.

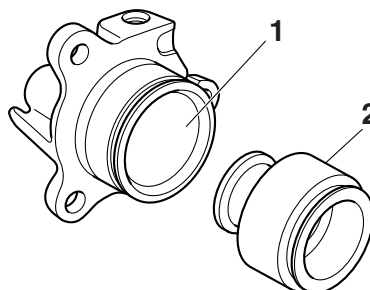

EAS25340

ASSEMBLING THE CLUTCH RELEASE CYLINDER

EW1D71006

WARNING

- Before installation, all internal clutch components must be cleaned and lubricated with clean or new clutch fluid.
- Never use solvents on internal clutch components as they will cause the piston seal to swell and distort.
- Whenever a clutch release cylinder is disassembled, replace the piston seal.



Recommended clutch fluid
Brake fluid DOT 4

EAS25350

INSTALLING THE CLUTCH RELEASE CYLINDER

1. Install:

- Copper washers **New**
- Clutch pipe “1”
- Clutch pipe union bolt “2”



Clutch pipe union bolt
26 Nm (2.6 m·kg, 19 ft·lb)

EWA1D77009

WARNING

Proper clutch pipe routing is essential to insure safe vehicle operation. Refer to “CABLE ROUTING (for XV19S(C)/ XV19M(C)/ XV19CTS(C)/ XV19CTM(C))” on page 2-51 and “CABLE ROUTING (for XV19CS(C)/ XV19C(C))” on page 2-67.

EC1D71005

CAUTION:

When installing the clutch pipe onto the clutch release cylinder, make sure the pipe “a” touches the projection “b” on the clutch release cylinder.

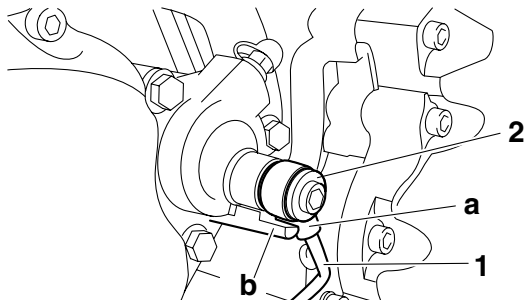

2. Fill:

- Clutch master cylinder reservoir (with the specified amount of the recommended clutch fluid)



Recommended clutch fluid
Brake fluid DOT 4

EWA13370

WARNING

- Use only the designated clutch fluid. Other clutch fluids may cause the rubber seals to deteriorate, causing leakage and poor clutch performance.
- Refill with the same type of clutch fluid that is already in the system. Mixing clutch fluids may result in a harmful chemical reaction, leading to poor clutch performance.
- When refilling, be careful that water does not enter the clutch fluid reservoir. Water will significantly lower the boiling point of the clutch fluid and could cause vapor lock.

ECA13420

CAUTION:

Clutch fluid may damage painted surfaces or plastic parts. Therefore, always clean up any spill clutch fluid immediately.

NOTE:

In order to ensure a correct reading of the clutch fluid level, make sure that the top of the reservoir is horizontal.

3. Bleed:

- Clutch system
Refer to “BLEEDING THE HYDRAULIC CLUTCH SYSTEM” on page 3-15.

4. Check:

- Clutch fluid level
Below the minimum level mark “a” → Add the recommended clutch fluid to the proper level. Refer to “CHECKING THE CLUTCH FLUID LEVEL” on page 3-14.

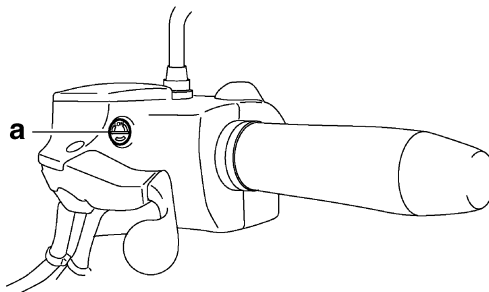

5. Check:

- Clutch lever operation

Soft or spongy feeling → Bleed the clutch system.

Refer to “BLEEDING THE HYDRAULIC CLUTCH SYSTEM” on page 3-15.

EAS25410

SHIFT SHAFT

Removing the shift shaft and stopper lever

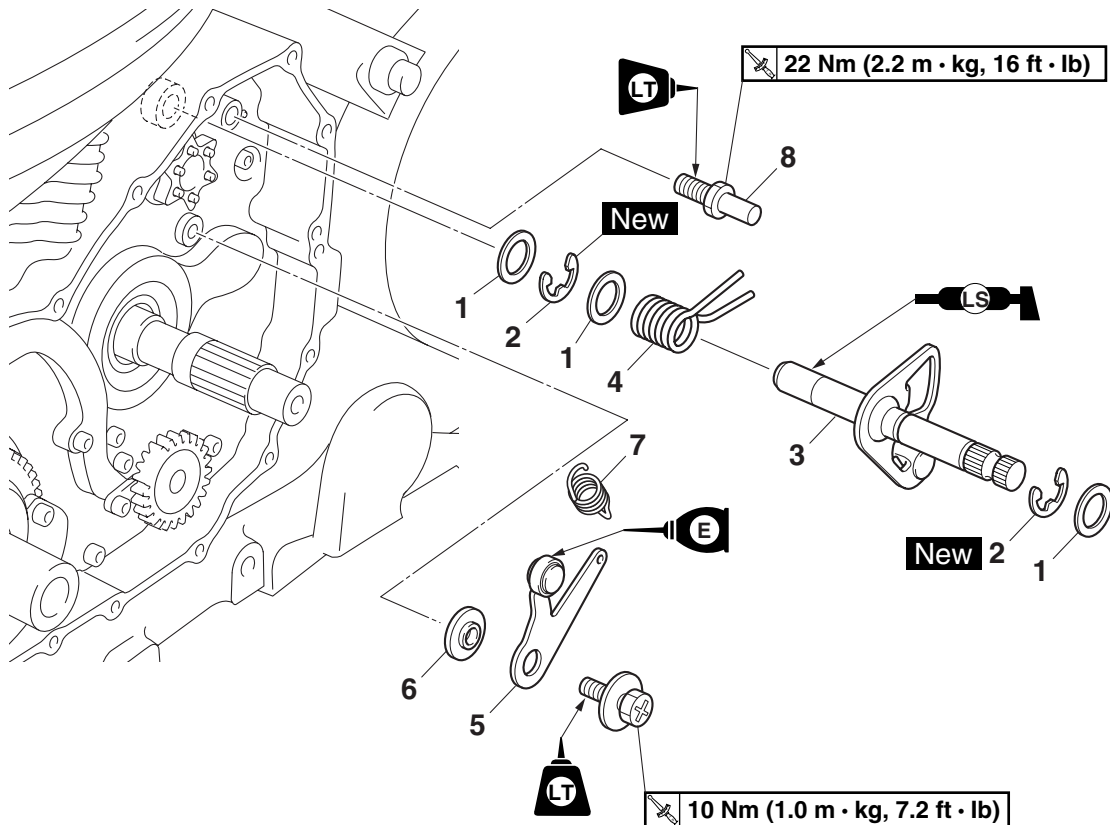

Order	Job/Parts to remove	Q'ty	Remarks
	Clutch housing		Refer to "CLUTCH" on page 5-53.
1	Washer	3	
2	Circlip	2	
3	Shift shaft	1	
4	Shift shaft spring	1	
5	Stopper lever	1	
6	Collar	1	
7	Stopper lever spring	1	
8	Shift shaft spring stopper	1	
			For installation, reverse the removal procedure.

EAS25420

CHECKING THE SHIFT SHAFT

1. Check:

- Shift shaft
Bends/damage/wear → Replace.
- Shift shaft spring
Damage/wear → Replace.

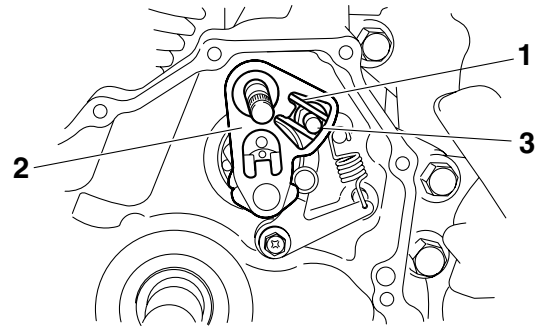

EAS25430

CHECKING THE STOPPER LEVER

1. Check:

- Stopper lever
Bends/damage → Replace.
Roller turns roughly → Replace the stopper lever.
- Stopper lever spring
Damage/wear → Replace.

EAS25450

INSTALLING THE SHIFT SHAFT

1. Install:

- Stopper lever “1”
- Collar
- Stopper lever bolt “2”
- Stopper lever spring “3”



Stopper lever bolt
10 Nm (1.0 m·kg, 7.2 ft·lb)
LOCTITE®

NOTE:

- Hook the ends of the stopper lever spring onto the stopper lever and the crankcase boss “4”.
- Mesh the stopper lever with the shift drum segment assembly.

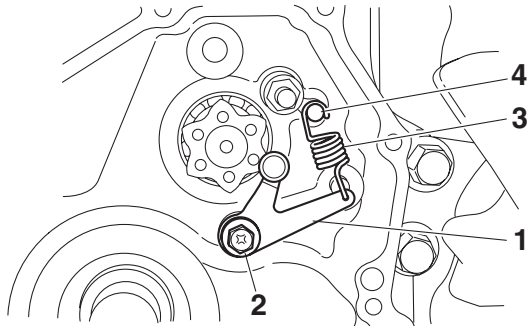

2. Install:

- Washers
- Circlips
- Shift shaft spring “1”
- Shift shaft “2”

NOTE:

Hook the end of the shift shaft spring onto the shift shaft spring stopper “3”.

GENERATOR AND STARTER CLUTCH

EAS24480

GENERATOR AND STARTER CLUTCH

Removing the stator coil

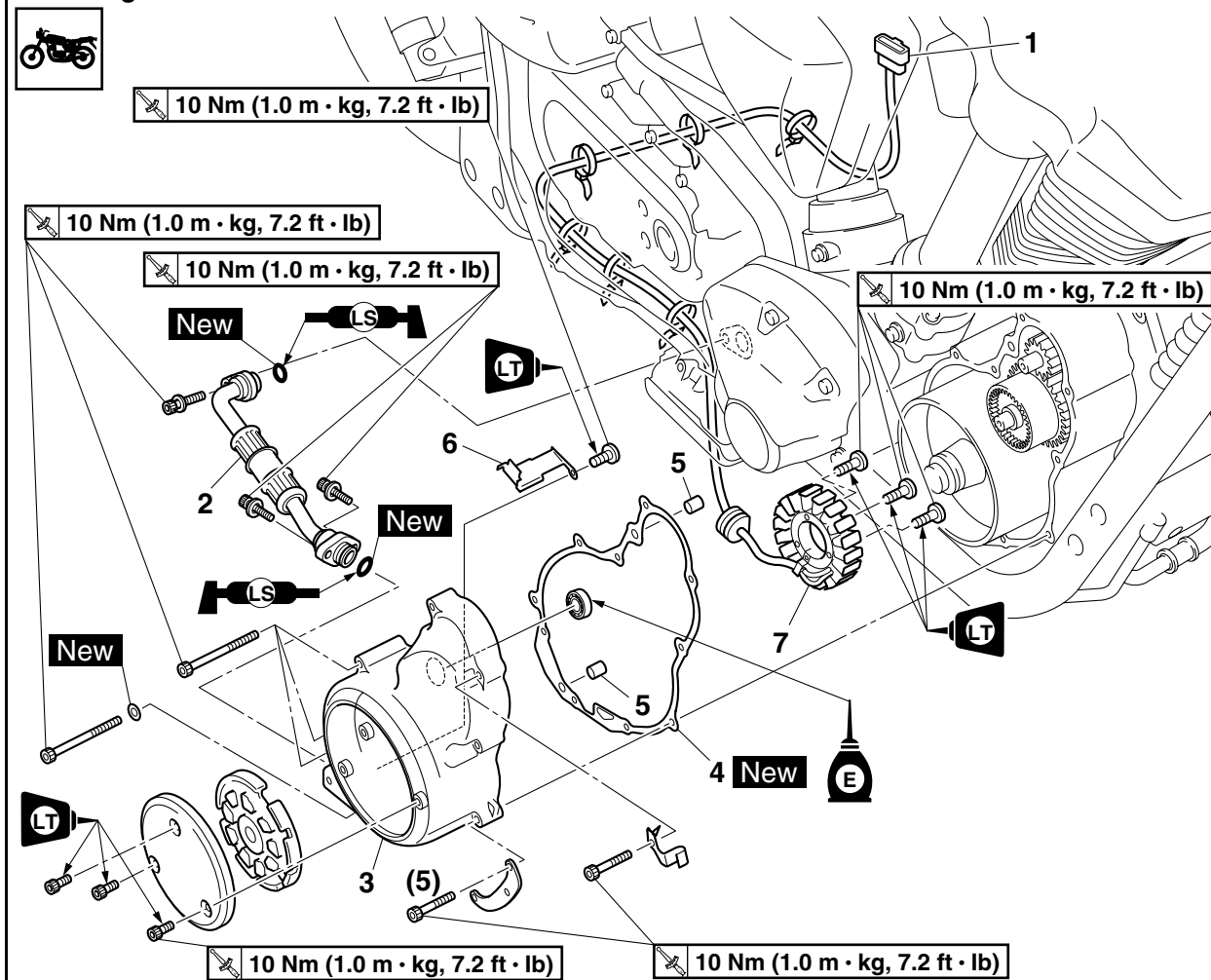

Order	Job/Parts to remove	Q'ty	Remarks
	Engine oil		Drain. Refer to "CHANGING THE ENGINE OIL" on page 3-11.
	Muffler/Exhaust pipes		Refer to "ENGINE REMOVAL" on page 5-1.
	Lead cover		Refer to "BELT DRIVE" on page 4-90.
	Clutch pipe		Refer to "CLUTCH" on page 5-53.
1	Stator coil coupler	1	Disconnect.
2	Oil delivery pipe 2	1	
3	Generator cover	1	
4	Generator cover gasket	1	
5	Dowel pin	2	
6	Stator coil lead holder	1	
7	Stator coil	1	
			For installation, reverse the removal procedure.

GENERATOR AND STARTER CLUTCH

Removing the generator rotor

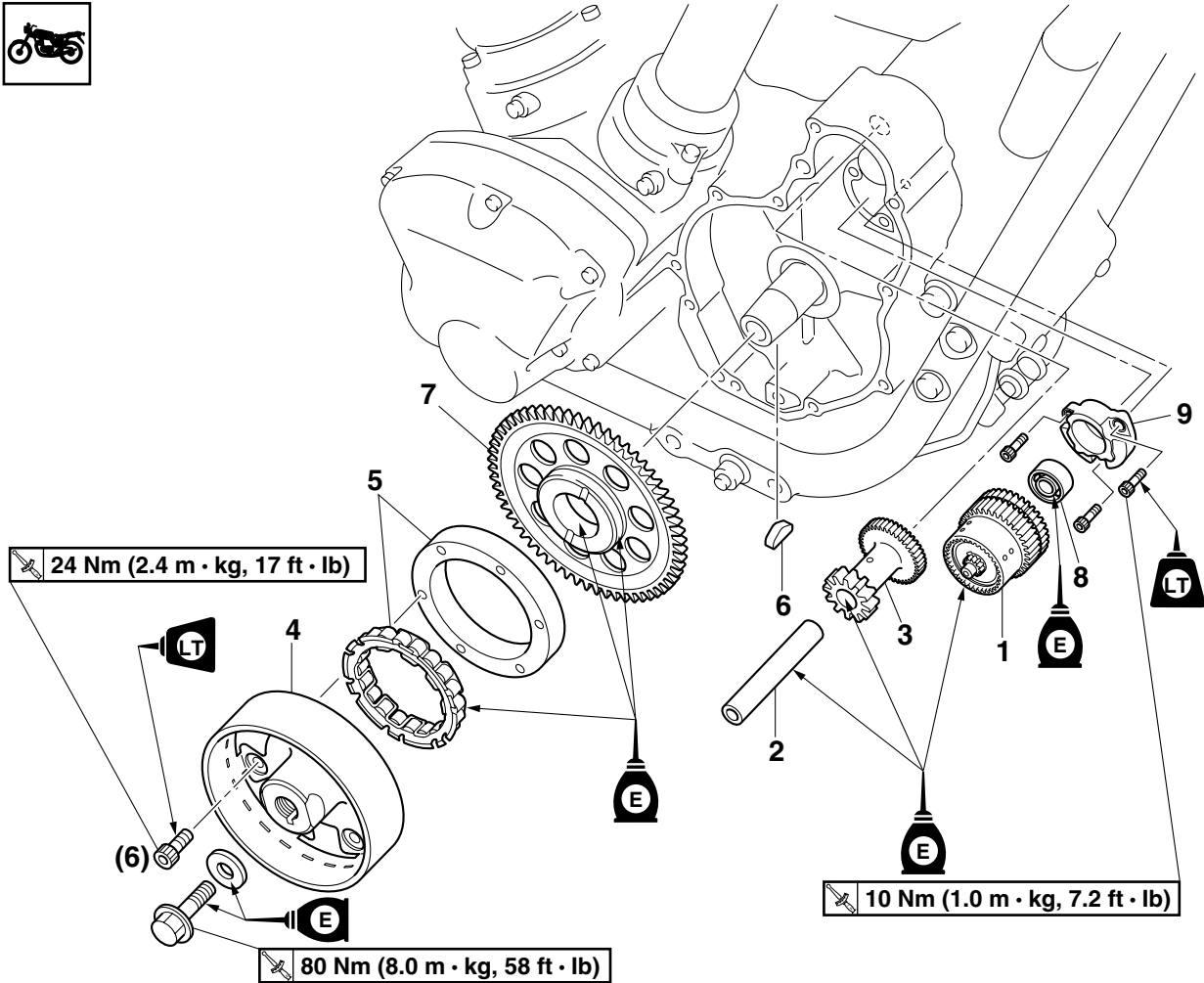

Order	Job/Parts to remove	Q'ty	Remarks
1	Torque limiter	1	
2	Starter clutch idle gear shaft	1	
3	Starter clutch idle gear	1	
4	Generator rotor	1	
5	Starter clutch	1	
6	Woodruff key	1	
7	Starter clutch gear	1	
8	Bearing	1	
9	Bearing housing	1	
			For installation, reverse the removal procedure.

GENERATOR AND STARTER CLUTCH

EAS24490

REMOVING THE GENERATOR

1. Remove:

- Generator rotor bolt "1"
- Washer

NOTE:

While holding the generator rotor "2" with the sheave holder "3", loosen the generator rotor bolt.

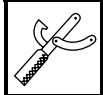

Sheave holder
90890-01701
Primary clutch holder
YS-01880-A

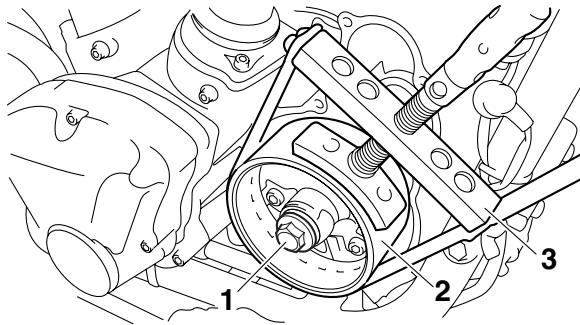

2. Remove:

- Generator rotor "1"
(with the rotor puller "2")
- Woodruff key



Rotor puller
90890-01080
Stator rotor puller
YM-01080-A

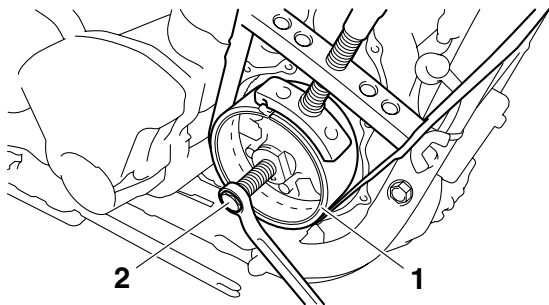

EAS24560

REMOVING THE STARTER CLUTCH

1. Remove:

- Starter clutch bolts
- Starter clutch

NOTE:

While holding the generator rotor "1" with the sheave holder "2", loosen the starter clutch bolts.



Sheave holder
90890-01701
Primary clutch holder
YS-01880-A

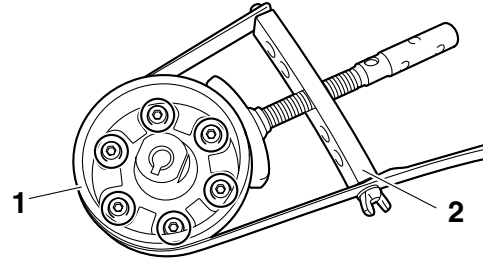

EAS24570

CHECKING THE STARTER CLUTCH

1. Check:

- Starter clutch rollers
Damage/wear → Replace.

2. Check:

- Starter clutch idle gear
- Starter clutch gear
Burrs/chips/roughness/wear → Replace the defective part(s).

3. Check:

- Starter clutch gear's contacting surfaces
Damage/pitting/wear → Replace the starter clutch gear.

4. Check:

- Starter clutch operation



- Install the starter clutch gear "1" onto the starter clutch and hold the generator rotor "2".
- When turning the starter clutch gear clockwise "A", the starter clutch and the starter clutch gear should engage, otherwise the starter clutch is faulty and must be replaced.
- When turning the starter clutch gear counter-clockwise "B", it should turn freely, otherwise the starter clutch is faulty and must be replaced.

GENERATOR AND STARTER CLUTCH

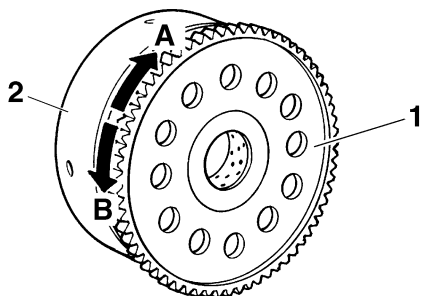

- Washer
- Generator rotor bolt "2"

NOTE:

- Clean the tapered portion of the generator shaft and the generator rotor hub.
- When installing the rotor, make sure the woodruff key is properly seated in the key way of the generator shaft.
- Lubricate the generator rotor bolt threads and washer mating surfaces with engine oil.



ET1D71020

CHECKING THE TORQUE LIMITER

1. Check:

- Torque limiter
Damage/wear → Replace.

NOTE:

Do not disassemble the torque limiter.

EAS24600

INSTALLING THE STARTER CLUTCH

1. Install:

- Starter clutch



Starter clutch bolt
24 Nm (2.4 m·kg, 17 ft·lb)
LOCTITE®

NOTE:

While holding the generator rotor "1" with the sheave holder "2", tighten the starter clutch bolts.

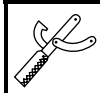

Sheave holder
90890-01701
Primary clutch holder
YS-01880-A

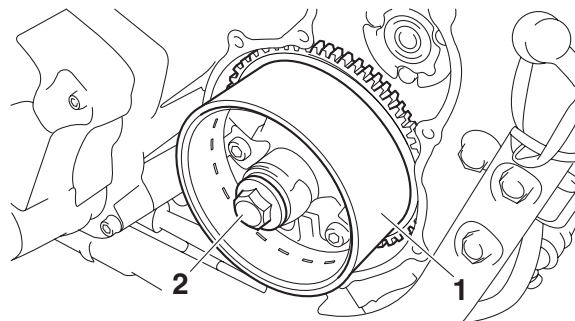
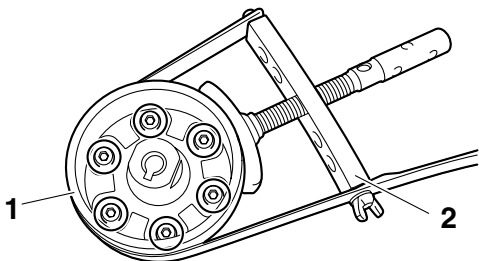

2. Tighten:

- Generator rotor bolt "1"



Generator rotor bolt
80 Nm (8.0 m·kg, 58 ft·lb)

NOTE:

While holding the generator rotor "2" with a sheave holder "3", tighten the generator rotor bolt.



Sheave holder
90890-01701
Primary clutch holder
YS-01880-A

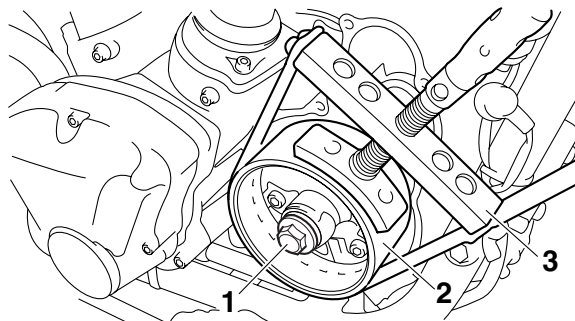

3. Apply:

- Sealant
(onto the stator coil lead grommet)



Yamaha bond No. 1215
90890-85505
(Three Bond No.1215®)

EAS24510

INSTALLING THE GENERATOR

1. Install:

- Woodruff key
- Generator rotor "1"

GENERATOR AND STARTER CLUTCH

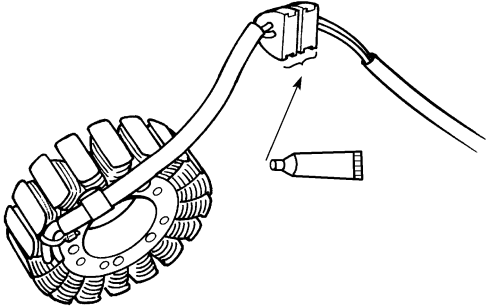

EAS24780

ELECTRIC STARTER

Removing the starter motor

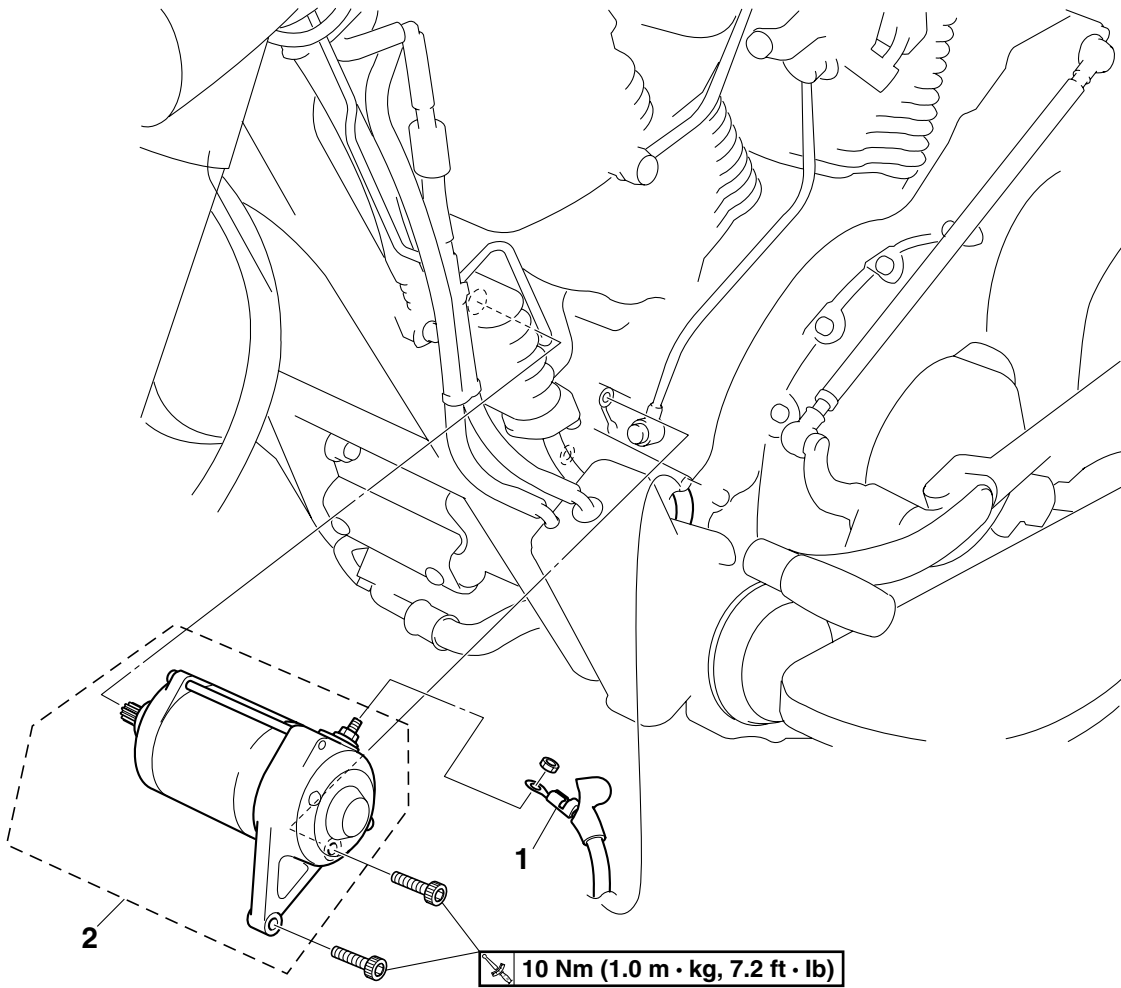

Order	Job/Parts to remove	Q'ty	Remarks
1	Starter motor lead	1	Disconnect.
2	Starter motor	1	
			For installation, reverse the removal procedure.

ELECTRIC STARTER

Disassembling the starter motor

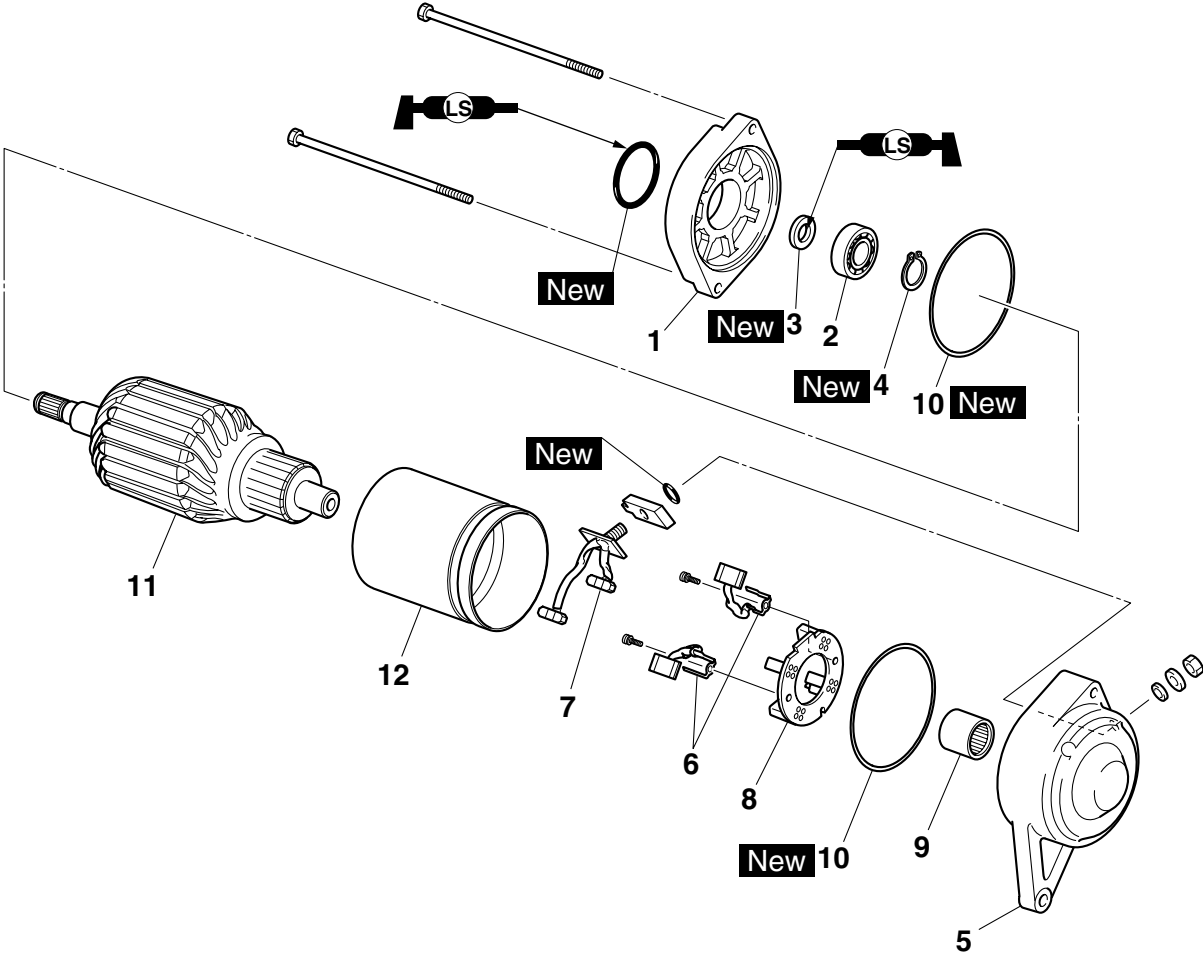

Order	Job/Parts to remove	Q'ty	Remarks
1	Starter motor front cover	1	
2	Bearing	1	
3	Oil seal	1	
4	Circlip	1	
5	Starter motor rear cover	1	
6	Brush	2	
7	Brush holder (along with the brushes)	1	
8	Brush seat (along with the brushes)	1	
9	Bearing	1	
10	Gasket	2	
11	Armature assembly	1	
12	Starter motor yoke	1	
			For assembly, reverse the disassembly procedure.

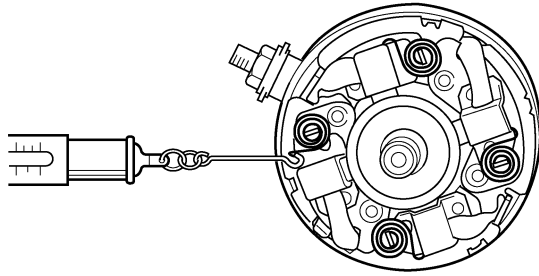

7. Check:

- Gear teeth
Damage/wear → Replace the gear.

8. Check:

- Bearings
- Oil seal
Damage/wear → Replace the defective part(s).

EAS24800

ASSEMBLING THE STARTER MOTOR

1. Install:

- Starter motor yoke "1"

NOTE: _____

Align the projection "a" on the brush holder with the slot "b" in the starter motor yoke.

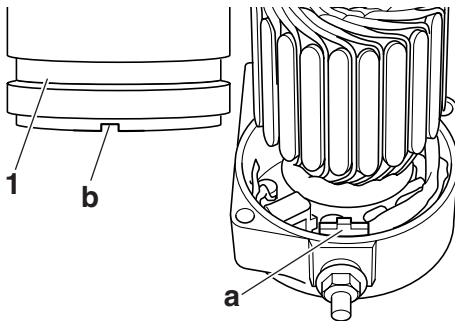

2. Install:

- Starter motor front cover "1"

NOTE: _____

Align the match mark "a" on the starter motor yoke with the match mark "b" on the starter motor front cover.

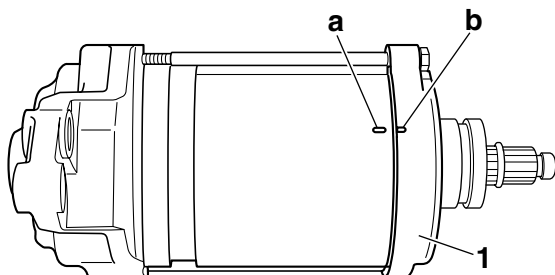

EAS25460

TRANSFER GEAR CASE

Removing the middle driven shaft

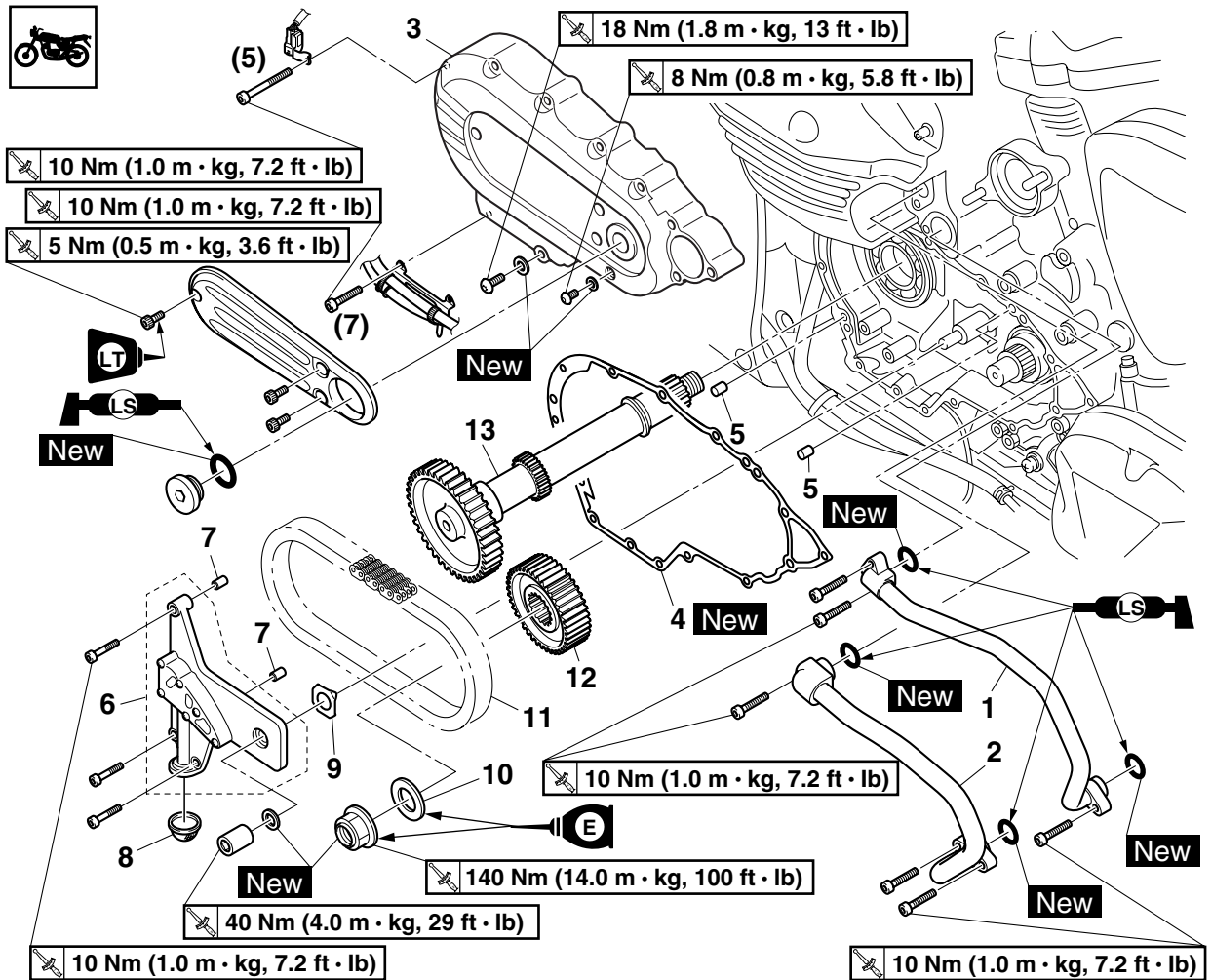

Order	Job/Parts to remove	Q'ty	Remarks
	Rider seat/Right side cover		Refer to "GENERAL CHASSIS" on page 4-1.
	Engine oil		Drain. Refer to "CHANGING THE ENGINE OIL" on page 3-11.
	Transfer gear oil		Drain. Refer to "CHANGING THE TRANSFER GEAR OIL" on page 3-14.
	Muffler/Exhaust pipes		Refer to "ENGINE REMOVAL" on page 5-1.
	Clutch release cylinder		Refer to "CLUTCH" on page 5-53.
	Drive pulley		Refer to "BELT DRIVE" on page 4-90.
1	Oil pipe 2	1	
2	Oil pipe 4	1	
3	Transfer gear case cover	1	
4	Transfer gear case gasket	1	
5	Dowel pin	2	
6	Transfer gear oil pump assembly	1	
7	Dowel pin	2	

TRANSFER GEAR CASE

Removing the middle driven shaft

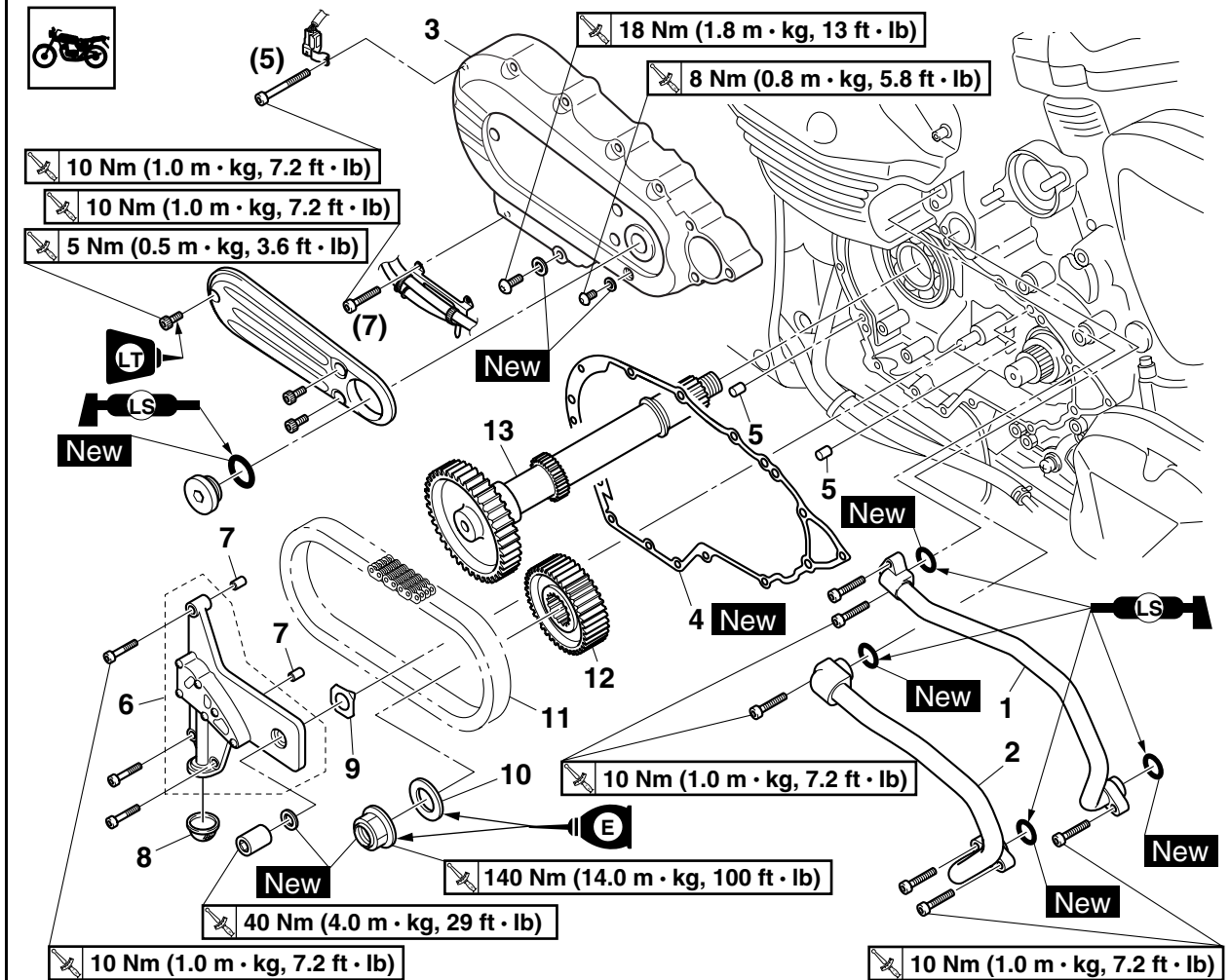

Order	Job/Parts to remove	Q'ty	Remarks
8	Oil strainer	1	
9	Gasket	1	
10	Conical spring washer	1	
11	Primary chain	1	
12	Middle drive gear	1	
13	Middle driven shaft	1	
			For installation, reverse the removal procedure.

TRANSFER GEAR CASE

Disassembling the transfer gear oil pump

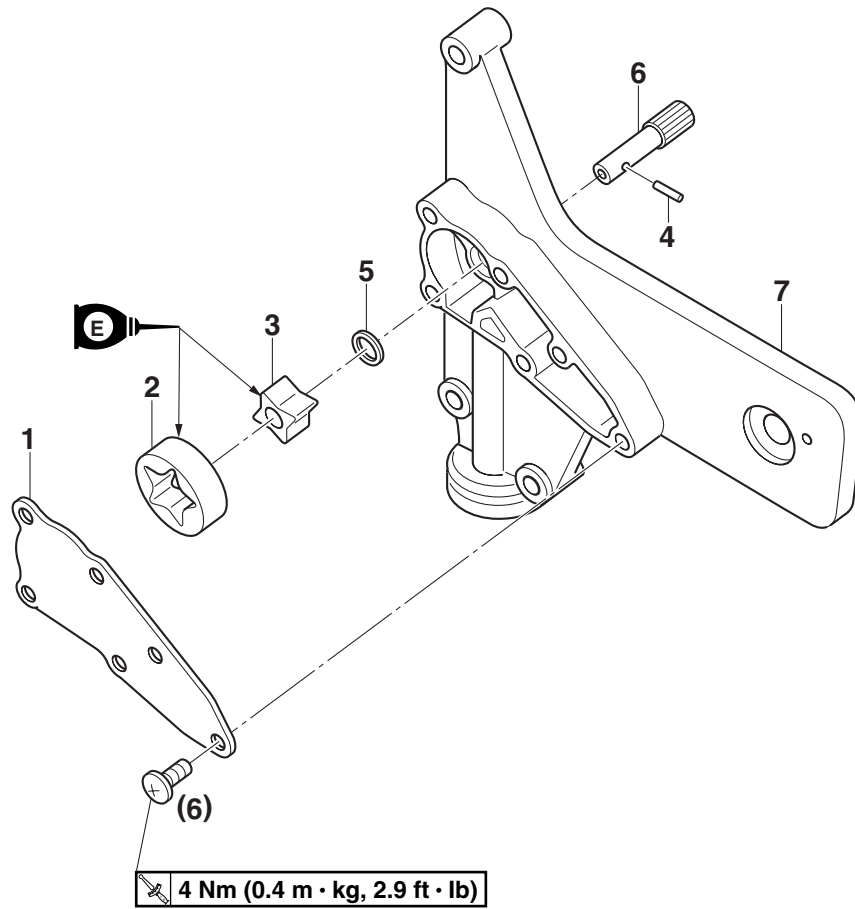

Order	Job/Parts to remove	Q'ty	Remarks
1	Transfer gear oil pump cover	1	
2	Transfer gear oil pump outer rotor	1	
3	Transfer gear oil pump inner rotor	1	
4	Pin	1	
5	Washer	1	
6	Transfer gear oil pump shaft	1	
7	Transfer gear oil pump housing	1	
			For assembly, reverse the disassembly procedure.

TRANSFER GEAR CASE

Removing the transfer gear case

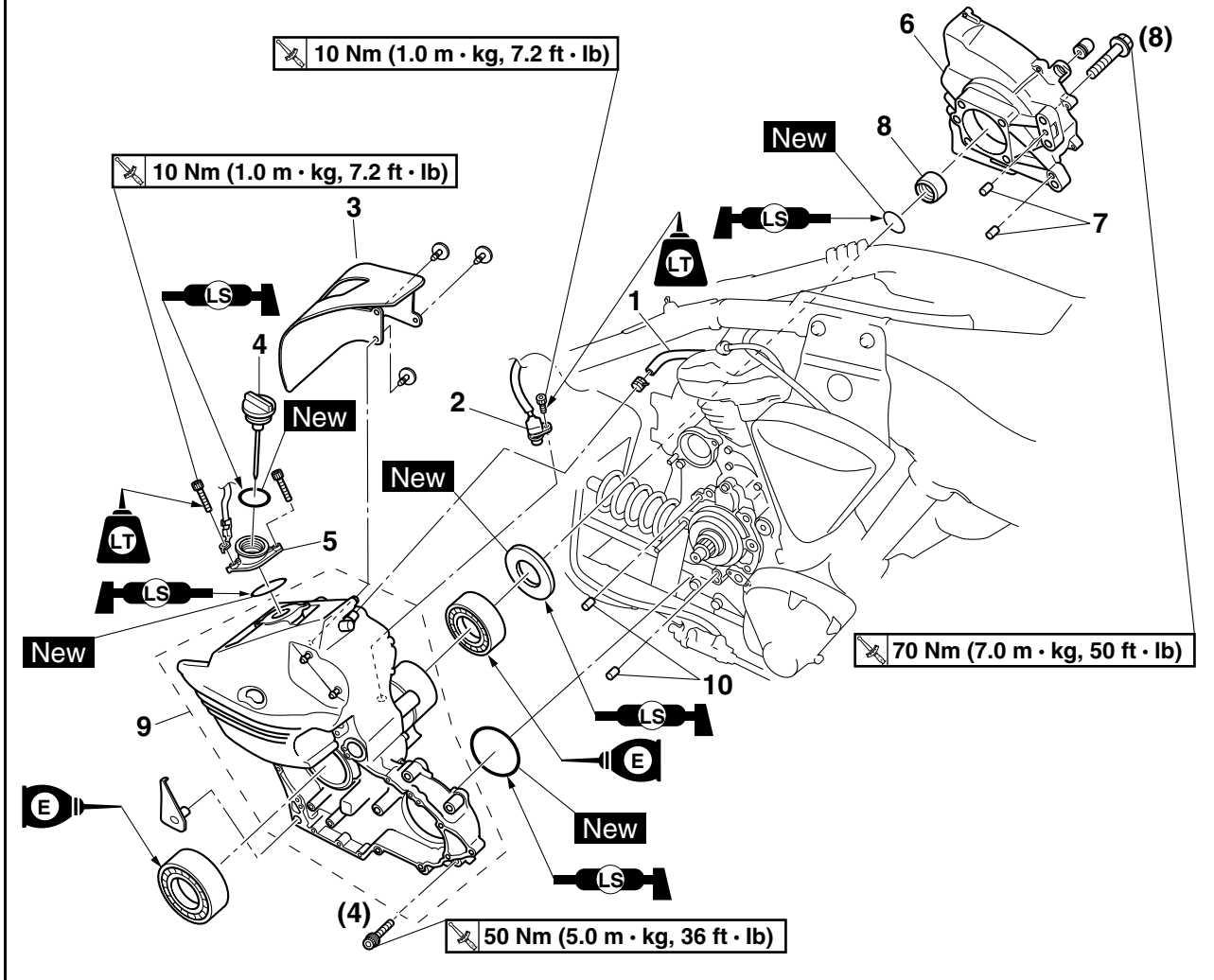

Order	Job/Parts to remove	Q'ty	Remarks
	Horn 2 connector		Disconnect. Refer to "ENGINE REMOVAL" on page 5-1.
	Battery box		Refer to "GENERAL CHASSIS" on page 4-1.
	Sub-fuel tank		Refer to "FUEL TANK" on page 6-1.
1	Oil tank breather hose	1	Disconnect.
2	Speed sensor	1	
3	Oil tank damper	1	
4	Dipstick	1	
5	Dipstick joint	1	
6	Drive pulley case	1	
7	Dowel pin	2	
8	Spacer	1	
9	Transfer gear case	1	
10	Dowel pin	2	
			For installation, reverse the removal procedure.

TRANSFER GEAR CASE

Disassembling the oil tank

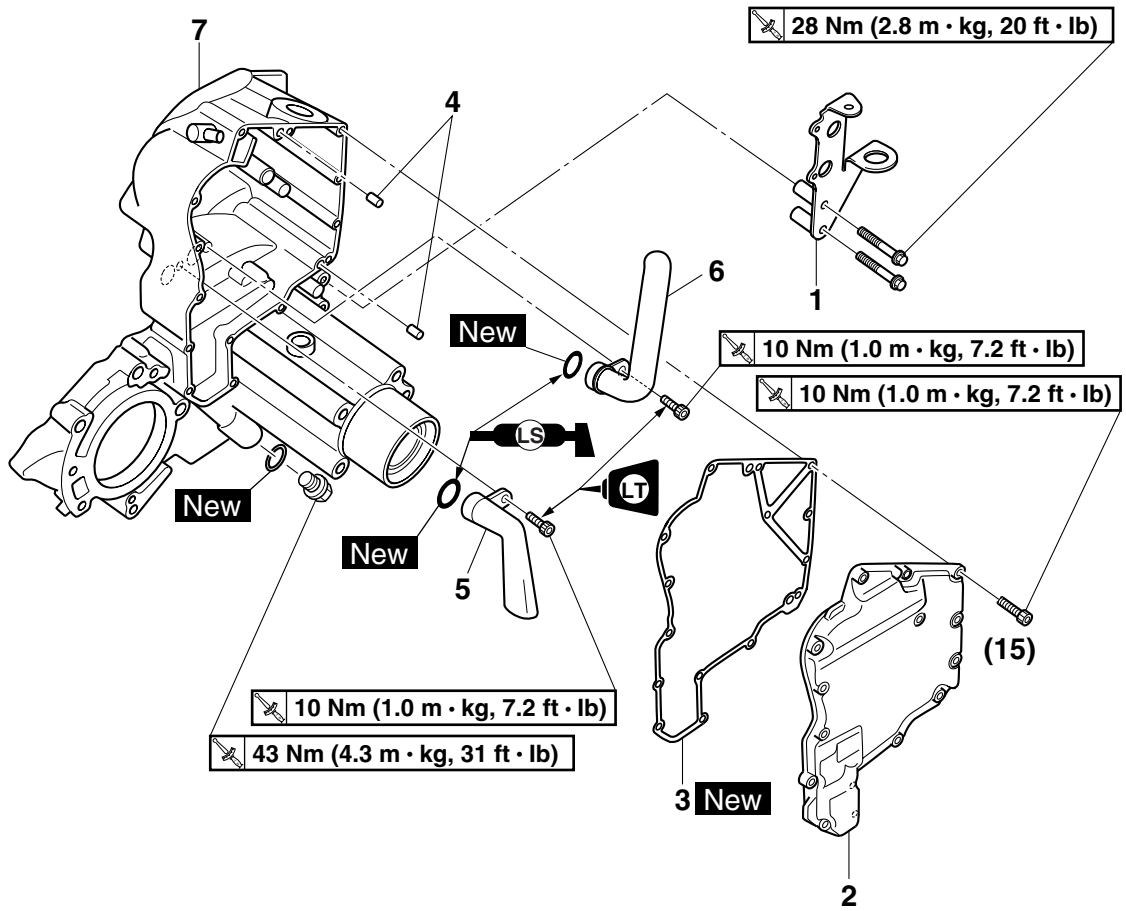

Order	Job/Parts to remove	Q'ty	Remarks
1	Sub-fuel tank bracket	1	
2	Oil tank cover	1	
3	Oil tank cover gasket	1	
4	Dowel pin	2	
5	Oil strainer	1	
6	Oil pipe 5	1	
7	Oil tank	1	
			For assembly, reverse the disassembly procedure.

EAS25470

REMOVING THE MIDDLE DRIVEN SHAFT

NOTE:

Loosen the middle drive gear nut before remove the drive pulley.

1. Install:

- Right rider footrest assembly
Refer to "ENGINE REMOVAL" on page 5-1.

2. Loosen:

- Middle drive gear nut "1"

NOTE:

When loosening the middle drive gear nut, press down on the brake pedal so the middle drive gear does not move.

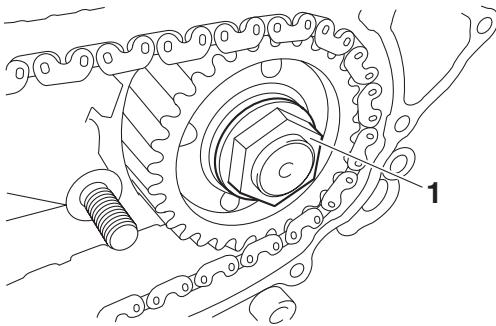

3. Remove:

- Primary chain "1"
- Middle drive gear "2"
- Middle driven shaft "3"

NOTE:

Remove the primary chain, middle drive gear and middle driven shaft at the same time.

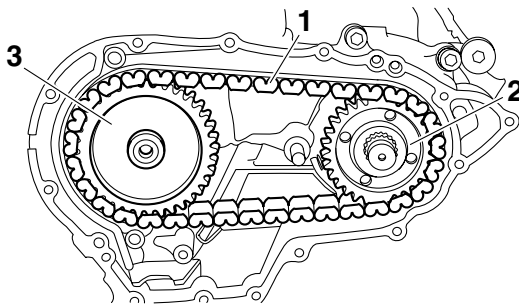

EAS25480

CHECKING THE MIDDLE DRIVE

1. Check:

- Middle drive gear
- Middle driven gear
Damage/wear → Replace the middle drive gear, middle driven shaft and primary chain as a set.

2. Check:

- Primary chain
Damage/stiffness → Replace the primary chain, middle drive gear and middle driven shaft as a set.

EAS25490

CHECKING THE OIL STRAINER

1. Check:

- Oil strainer
Damage → Replace.
Contaminants → Clean with engine oil.

EAS25500

CHECKING THE TRANSFER GEAR OIL PUMP

1. Check:

- Transfer gear oil pump housing
- Transfer gear oil pump cover
Cracks/damage/wear → Replace the defective part(s).

2. Measure:

- Inner-rotor-to-outer-rotor-tip clearance "a"
- Outer-rotor-to-oil-pump-housing clearance "b"
- Oil-pump-housing-to-inner-rotor-and-outer-rotor clearance "c"
Out of specification → Replace the transfer gear oil pump.

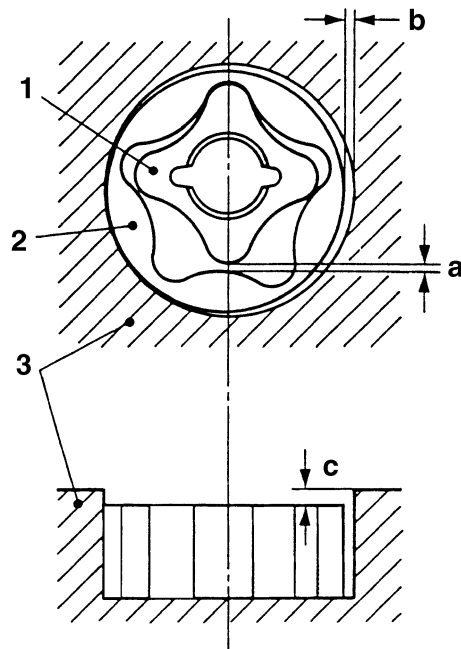

1. Transfer gear oil pump inner rotor
2. Transfer gear oil pump outer rotor
3. Transfer gear oil pump housing

TRANSFER GEAR CASE



Inner-rotor-to-outer-rotor-tip clearance
 Less than 0.12 mm (0.0047 in)
Limit
 0.20 mm (0.0079 in)
Outer-rotor-to-oil-pump-housing clearance
 0.10–0.15 mm (0.0039–0.0059 in)
Limit
 0.22 mm (0.0087 in)
Oil-pump-housing-to-inner-and-outer-rotor clearance
 0.04–0.09 mm (0.0016–0.0035 in)
Limit
 0.160 mm (0.0063 in)

3. Check:

- Transfer gear oil pump operation
 Rough movement → Repeat steps (1) and (2) or replace the defective part(s).

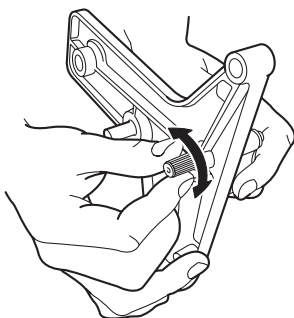

EAS25510

CHECKING THE OIL PIPES

1. Check:

- Oil pipes
 Damage → Replace.

EAS25520

ASSEMBLING THE TRANSFER GEAR OIL PUMP

1. Lubricate:

- Transfer gear oil pump inner rotor
- Transfer gear oil pump outer rotor
- Transfer gear oil pump shaft
 (with the recommended lubricant)

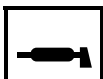

Recommended lubricant
Engine oil

2. Install:

- Transfer gear oil pump shaft “1”
 (to the transfer gear oil pump housing “2”)
- Washer “3”
- Pin “4”
- Transfer gear oil pump inner rotor “5”
- Transfer gear oil pump outer rotor “6”

- Transfer gear oil pump cover “7”

NOTE:

When installing the inner rotor, align the pin in the oil pump shaft with the groove in the inner rotor.



Oil pump housing screw
 4 Nm (0.4 m·kg, 2.9 ft·lb)

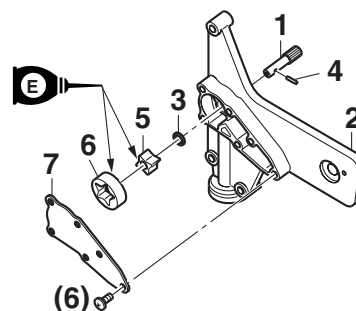

3. Check:

- Transfer gear oil pump operation
 Refer to “CHECKING THE TRANSFER GEAR OIL PUMP” on page 5-91.

EAS25530

INSTALLING THE TRANSFER GEAR CASE

1. Install:

- Spacer “1”

NOTE:

Install the spacer with its groove “a” towards the drive pulley.

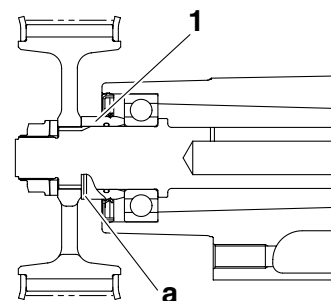

2. Install:

- Middle driven shaft “1”
- Middle drive gear “2”
- Primary chain “3”
 (into the transfer gear case)
- Drive pulley nut

NOTE:

- Install the primary chain with its blue link “a” facing outward.
- Install the middle drive gear “2” with its chamfered side facing “b” the transfer gear case.

- Install the middle driven shaft, middle drive gear and primary chain at the same time.
- Align the splines on the middle drive gear with the splines on the drive axle.
- Temporarily install the drive pulley nut onto the middle driven shaft.

- Remove:
 - Drive pulley nut

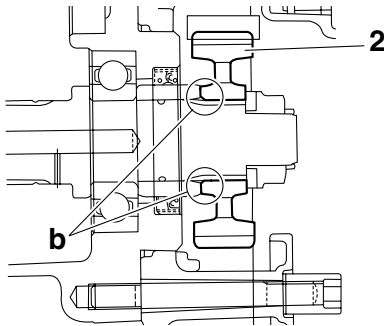
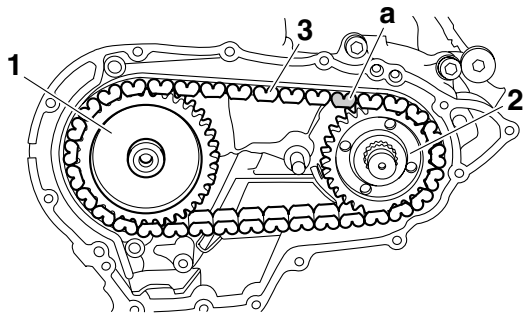

3. Install:

- Conical spring washer “1”
- Middle drive gear nut “2” **New**

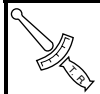

Middle drive gear nut
140 Nm (14.0 m·kg, 100 ft·lb)

NOTE:

- Lubricate the middle drive gear nut threads and conical spring washer mating surfaces with engine oil.
- Install the conical spring washer “1” with the “OUT” mark “a” facing out.
- Stake the middle drive gear nut “2” at a cutout “b” in the drive axle.

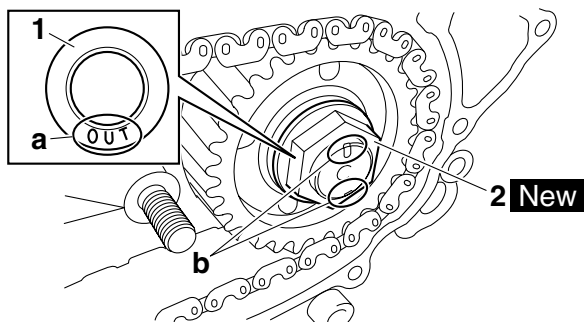

EAS25540

CRANKCASE

Separating the crankcase

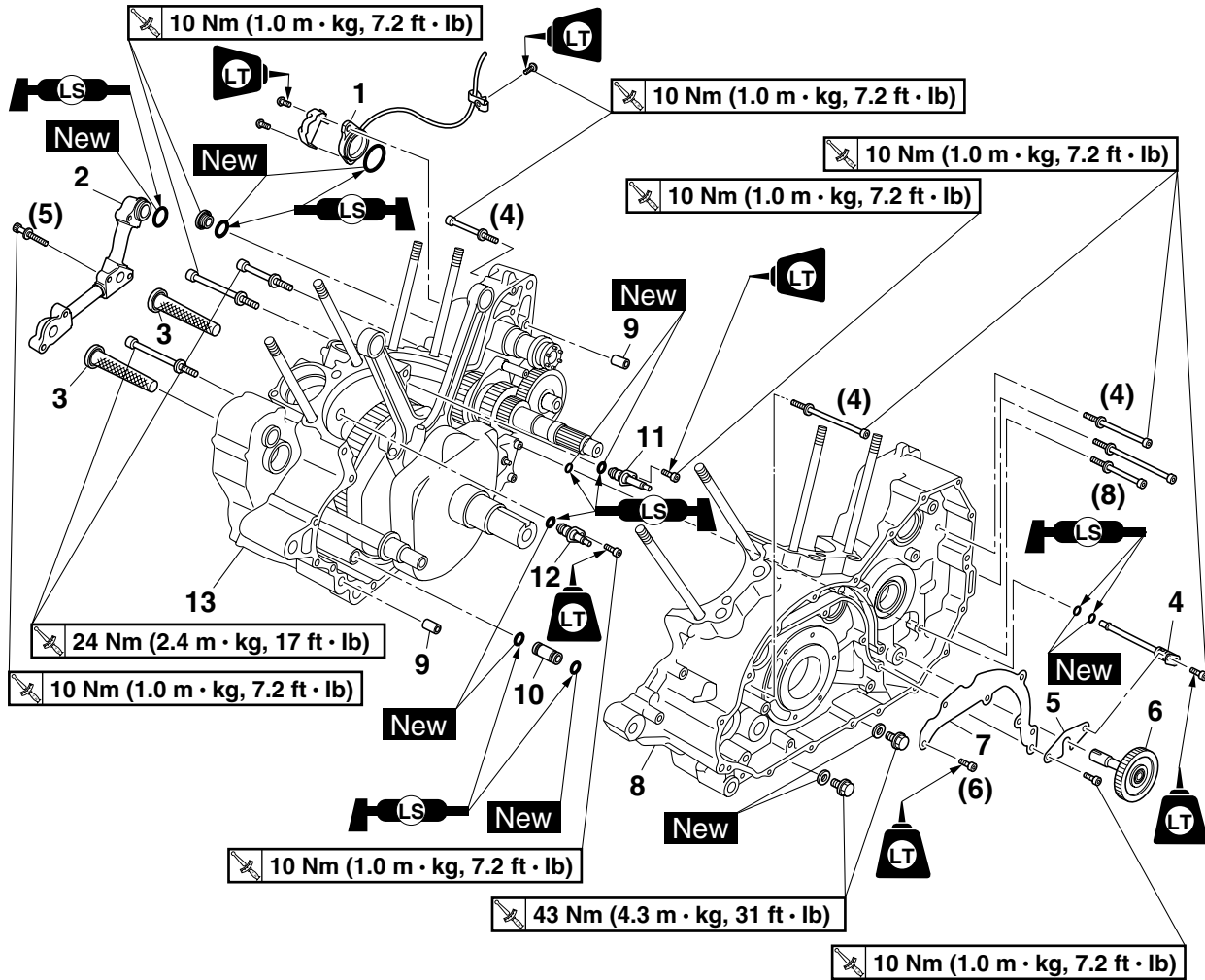

Order	Job/Parts to remove	Q'ty	Remarks
	Engine		Refer to "ENGINE REMOVAL" on page 5-1.
	Camshafts		Refer to "CAMSHAFTS" on page 5-17.
	Pistons		Refer to "CYLINDERS AND PISTONS" on page 5-48.
	Left balancer driven gear housing		Refer to "CLUTCH" on page 5-53.
	Shift shaft		Refer to "SHIFT SHAFT" on page 5-75.
	Generator rotor		Refer to "GENERATOR AND STARTER CLUTCH" on page 5-77.
1	Neutral switch	1	
2	Oil pipe 3	1	
3	Oil strainer	2	
4	Oil delivery pipe 3	1	
5	Engine oil pump driven gear stopper	1	
6	Engine oil pump driven gear	1	
7	Oil baffle plate (left crankcase)	1	
8	Left crankcase	1	
9	Dowel pin	2	

Separating the crankcase

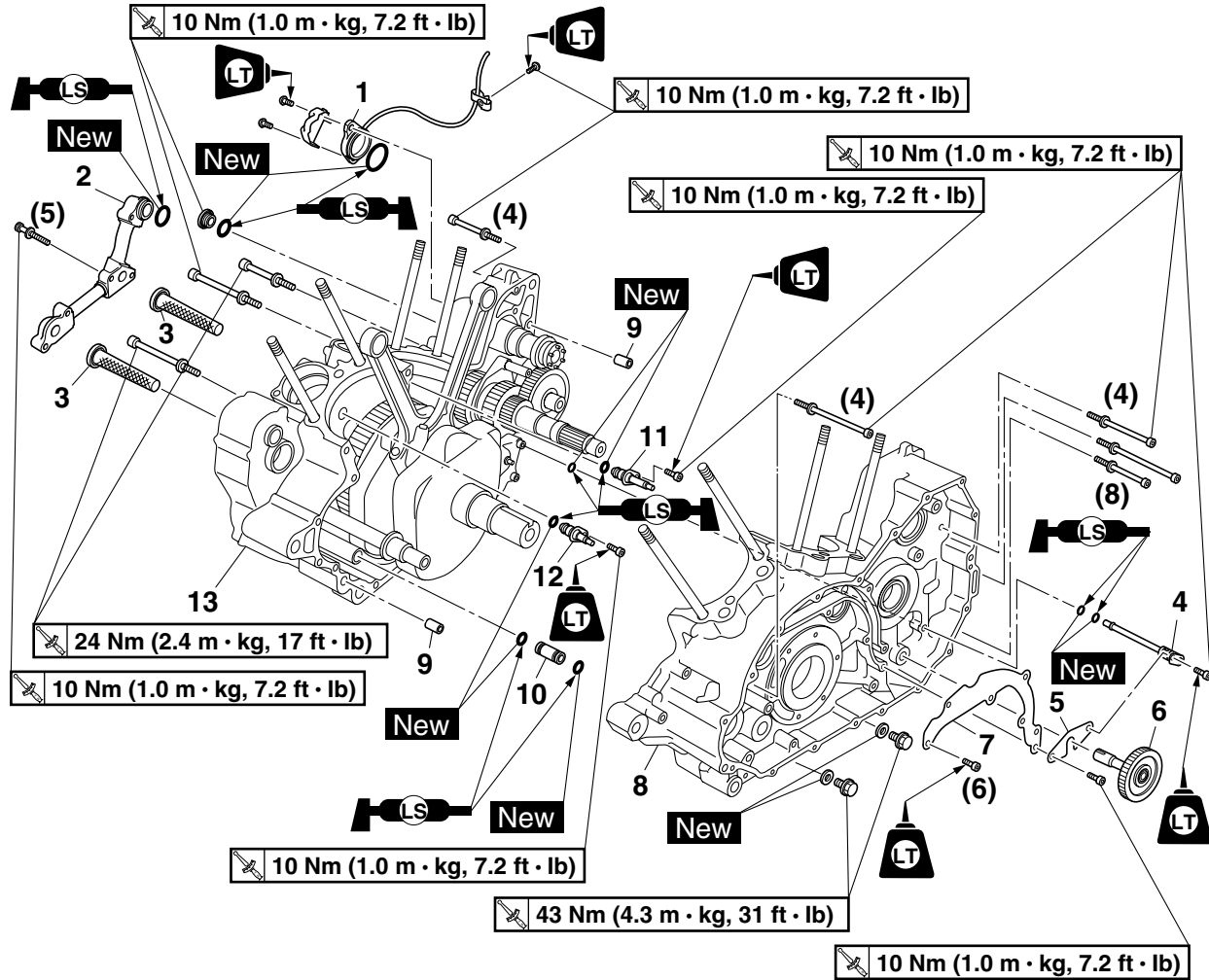

Order	Job/Parts to remove	Q'ty	Remarks
10	Joint pipe	1	
11	Oil pipe	1	"R" mark
12	Oil pipe	1	"F" mark
13	Right crankcase	1	
			For installation, reverse the removal procedure.

Removing the oil seals and bearings

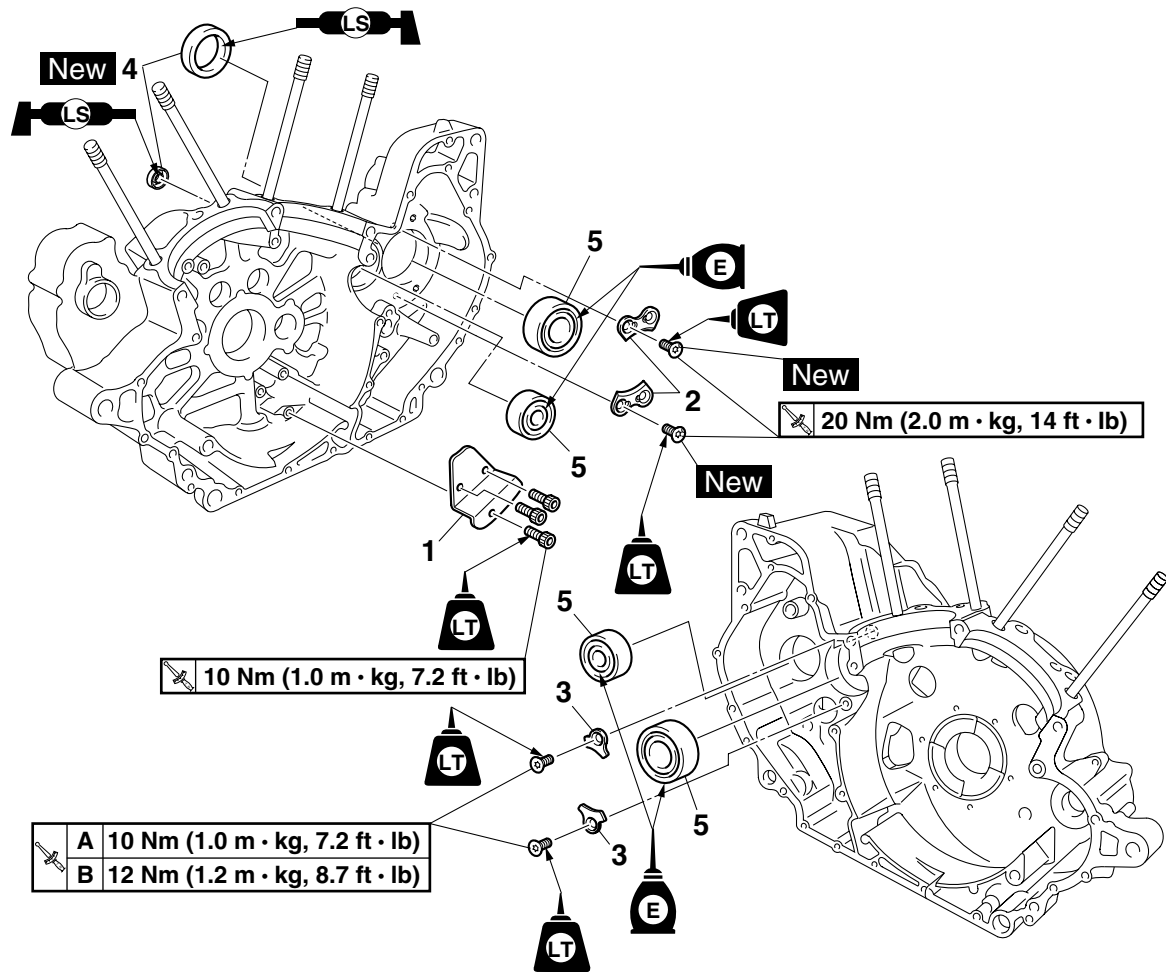

Order	Job/Parts to remove	Q'ty	Remarks
	Oil pump		Refer to "OIL PUMP" on page 5-100.
	Crankshaft		Refer to "CRANKSHAFT" on page 5-106.
	Transmission		Refer to "TRANSMISSION" on page 5-112.
1	Oil baffle plate (right crankcase)	1	
2	Bearing retainer	2	
3	Bearing retainer	2	
4	Oil seal	2	
5	Bearing	4	
			For installation, reverse the removal procedure.

A: For XV19S(C)/ XV19M(C)/ XV19CTS(C)/ XV19CTM(C)
 B: For XV19CS(C)/ XV19C(C)

EAS25570

DISASSEMBLING THE CRANKCASE

1. Remove:

- Crankcase bolts

NOTE:

- Loosen each bolt 1/4 of a turn at a time, in stages and in a crisscross pattern. After all of the bolts are fully loosened, remove them.
- Loosen the bolts in decreasing numerical order (refer to the numbers in the illustration).

- M8 × 90 mm bolts: “1”, “2”
- M8 × 65 mm bolt: “3”
- M6 × 100 mm bolts: “4”, “9”–“11”
- M6 × 80 mm bolt: “12”
- M6 × 70 mm bolts: “13”–“16”
- M6 × 60 mm bolts: “5”–“8”
- M6 × 35 mm bolts: “17”–“24”

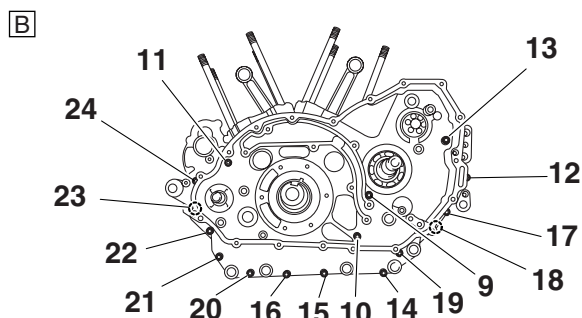
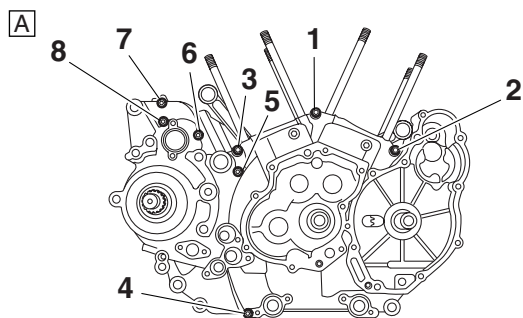

- A. Right crankcase
B. Left crankcase

2. Remove:

- Left crankcase

ECA13900

CAUTION:

Tap on one side of the crankcase with a soft-face hammer. Tap only on reinforced portions of the crankcase, not on the crankcase mating surfaces. Work slowly and carefully and make sure the crankcase halves separate evenly.

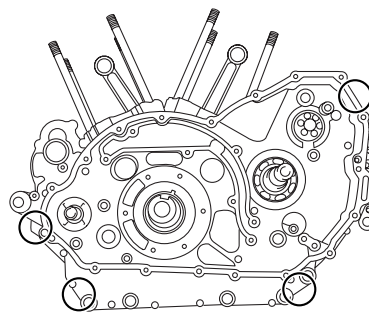

EAS25580

CHECKING THE CRANKCASE

1. Thoroughly wash the crankcase halves in a mild solvent.
2. Thoroughly clean all the gasket surfaces and crankcase mating surfaces.
3. Check:
 - Crankcase
Cracks/damage → Replace.
 - Oil delivery passages
Obstruction → Blow out with compressed air.

ET1D71005

CHECKING THE BEARINGS AND OIL SEAL

1. Check:
 - Bearings
Clean and lubricate the bearings, then rotate the inner race with your finger.
Rough movement → Replace.
 - Oil seals
Damage/wear → Replace.

EAS25590

CHECKING THE OIL DELIVERY PIPE AND OIL PIPE

1. Check:
 - Oil delivery pipe
Damage → Replace.
 - Oil pipes
Obstruction → Wash and blow out with compressed air.

ET1D71038

CHECKING THE OIL STRAINERS

1. Check:
 - Oil strainers
Damage → Replace.
Contaminants → Clean with solvent.

EAS25610

CHECKING THE ENGINE OIL PUMP DRIVEN GEAR

1. Check:
 - Engine oil pump driven gear
Chips/pitting/roughness/wear → Replace.

ET1D71034

INSTALLING THE BEARING RETAINERS

1. Install:

- Bearing retainers “1”

NOTE:

- Apply locking agent (LOCTITE®) to the threads of the bearing retainer bolts.
- Stake the bearing retainer bolts “2”.

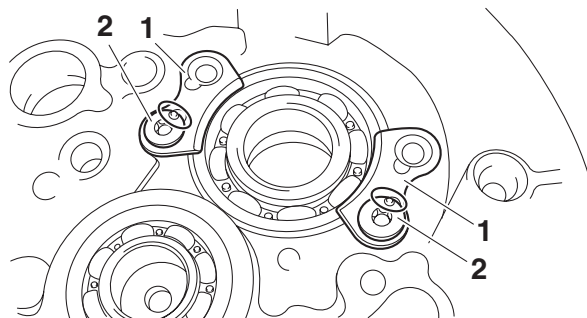

EAS25690

ASSEMBLING THE CRANKCASE

1. Apply:

- Sealant
(onto the crankcase mating surfaces)



Yamaha bond No. 1215
90890-85505
(Three Bond No.1215®)

NOTE:

Do not allow any sealant to come into contact with the oil gallery.

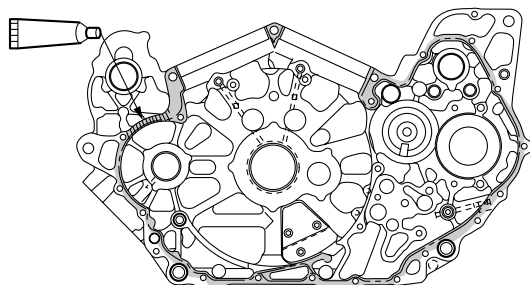

2. Install:

- Oil pipe (“F” mark) “1”
- Oil pipe (“R” mark) “2”
- Dowel pins “3”
- Joint pipe “4”

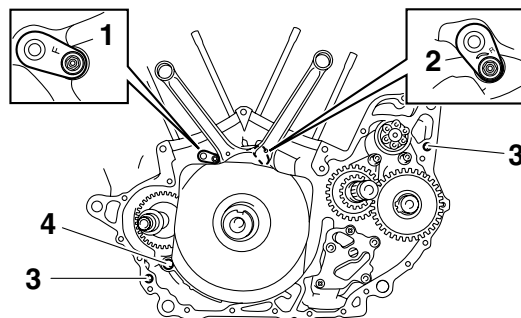

3. Install:

- Left crankcase
(onto the right crankcase)

NOTE:

Tap lightly on the left crankcase with a soft-face hammer.

4. Install:

- Crankcase bolts (M6)
- Crankcase bolts (M8)



Crankcase bolt (M6)
10 Nm (1.0 m·kg, 7.2 ft·lb)
Crankcase bolt (M8)
24 Nm (2.4 m·kg, 17 ft·lb)

NOTE:

- Lubricate the bolt threads with engine oil.
- Tighten each bolt 1/4 of a turn at a time, in stages and in a crisscross pattern.
- Tighten the bolts in numerical order (refer to the numbers in the illustration).

- M8 × 90 mm bolts: “1”, “2”
- M8 × 65 mm bolt: “3”
- M6 × 100 mm bolts: “4”, “9”–“11”
- M6 × 80 mm bolt: “12”
- M6 × 70 mm bolts: “13”–“16”
- M6 × 60 mm bolts: “5”–“8”
- M6 × 35 mm bolts: “17”–“24”

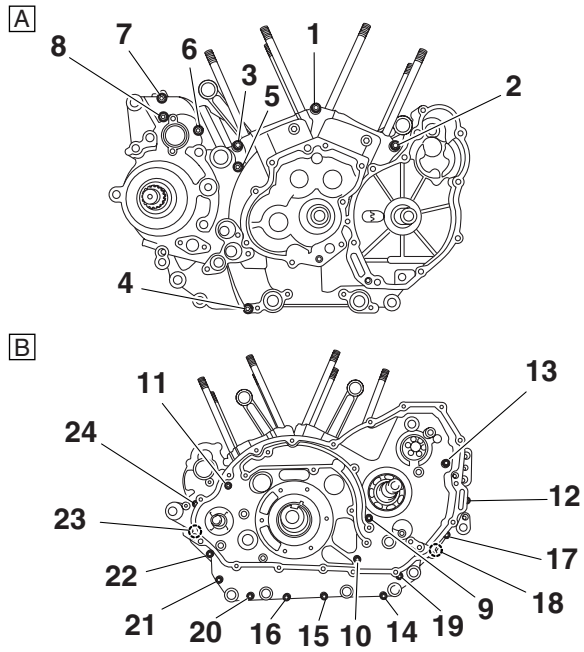

- A. Right crankcase
- B. Left crankcase

- 5. Apply:
 - Engine oil
(onto the crankshaft pin bearings and oil delivery holes)
- 6. Check:
 - Crankshaft and transmission operation
Rough movement → Repair.

EAS24910

OIL PUMP

Removing the oil pump

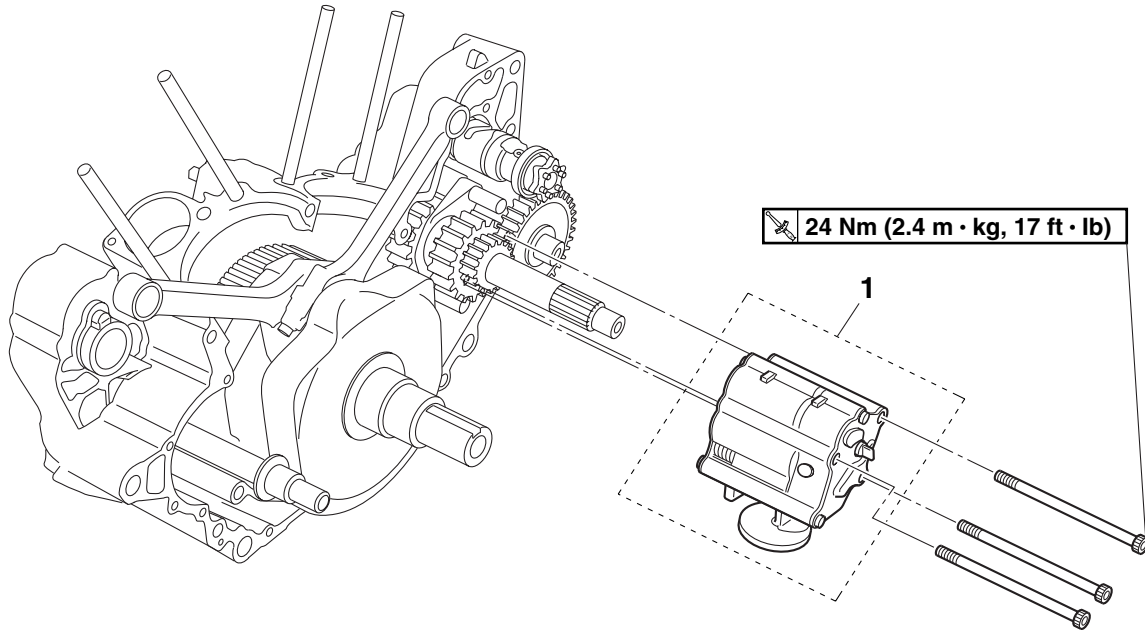

Order	Job/Parts to remove	Q'ty	Remarks
	Crankcase		Separate. Refer to "CRANKCASE" on page 5-94.
1	Oil pump assembly	1	
			For installation, reverse the removal procedure.

Disassembling the oil pump

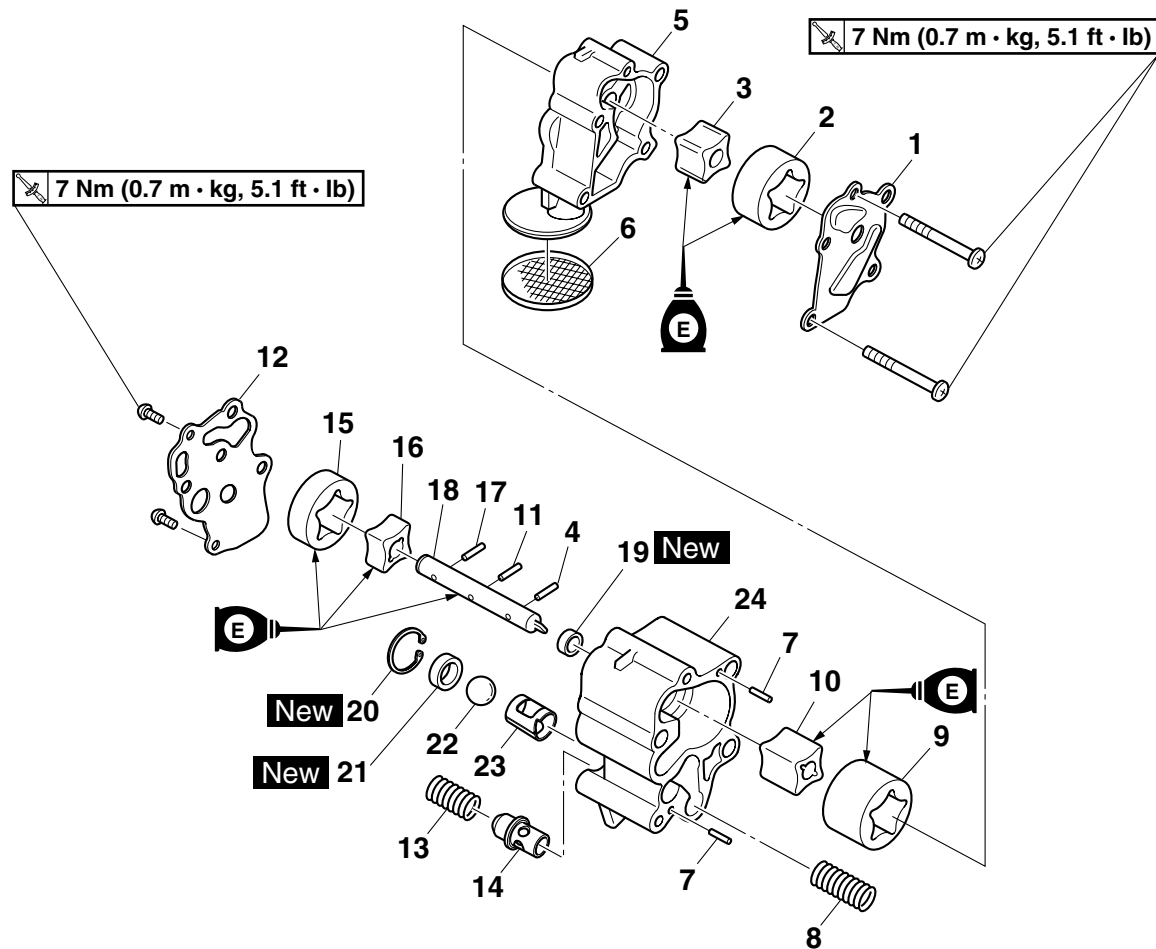

Order	Job/Parts to remove	Q'ty	Remarks
1	Oil pump housing cover 1	1	
2	Oil scavenging pump outer rotor 1	1	
3	Oil scavenging pump inner rotor 1	1	
4	Pin	1	
5	Oil pump housing 1	1	
6	Oil strainer	1	
7	Pin	2	
8	Ball spring	1	
9	Oil scavenging pump outer rotor 2	1	
10	Oil scavenging pump inner rotor 2	1	
11	Pin	1	
12	Oil pump housing cover 2	1	
13	Relief valve spring	1	
14	Relief valve	1	
15	Oil feed pump outer rotor	1	
16	Oil feed pump inner rotor	1	
17	Pin	1	

Disassembling the oil pump

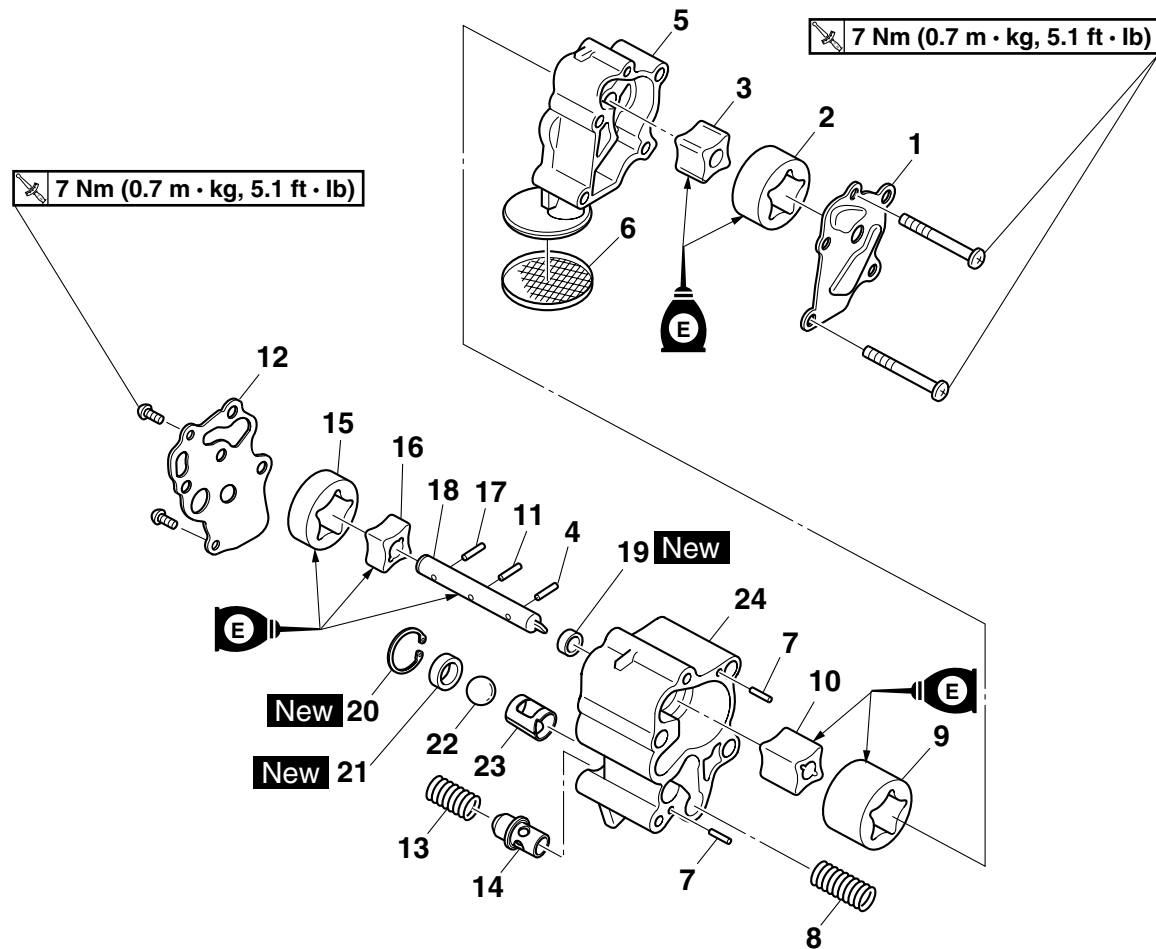

Order	Job/Parts to remove	Q'ty	Remarks
18	Oil pump shaft	1	
19	Oil seal	1	
20	Circlip	1	
21	Oil seal	1	
22	Ball	1	
23	Ball guide	1	
24	Oil pump housing 2	1	
			For assembly, reverse the disassembly procedure.

EAS24960

CHECKING THE OIL PUMP

1. Check:

- Oil pump housing
- Oil pump housing cover
Cracks/damage/wear → Replace the defective part(s).

2. Measure:

- Inner-rotor-to-outer-rotor-tip clearance “a”
- Outer-rotor-to-oil-pump-housing clearance “b”
- Oil-pump-housing-to-inner-rotor-and-outer-rotor clearance “c”
Out of specification → Replace the oil pump.



Inner-rotor-to-outer-rotor-tip clearance

Less than 0.12 mm (0.0047 in)

Limit

0.20 mm (0.0079 in)

Oil-pump-housing-to-inner-and-outer-rotor clearance

0.06–0.13 mm (0.0024–0.0051 in)

Limit

0.20 mm (0.0079 in)

Outer-rotor-to-oil-pump-housing clearance

0.09–0.19 mm (0.0035–0.0075 in)

Limit

0.26 mm (0.0102 in)

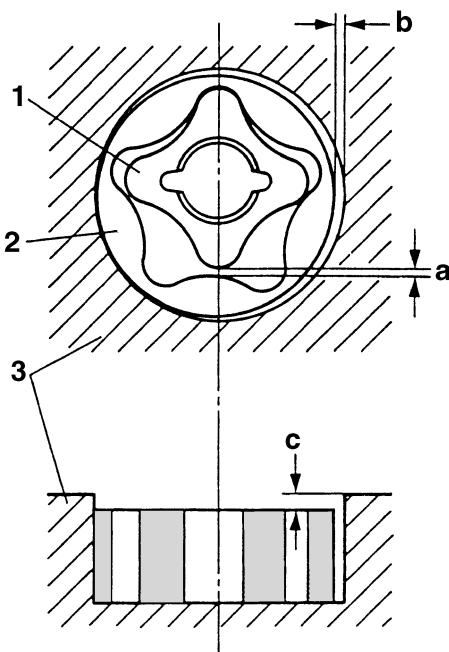

1. Inner rotor
2. Outer rotor
3. Oil pump housing

3. Check:

- Oil pump operation
Rough movement → Repeat steps (1) and (2) or replace the defective part(s).

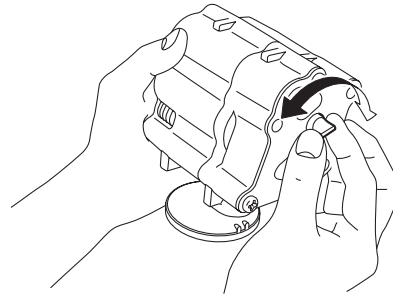

EAS24970

CHECKING THE RELIEF VALVE

1. Check:

- Relief valve body
- Relief valve
- Relief valve spring
Damage/wear → Replace the defective part(s).

ET1D71035

CHECKING THE BALL SPRING AND RELIEF VALVE SPRING

1. Measure:

- Ball spring free length
- Relief valve spring free length
Out of specification → Replace the defective part(s).



Ball spring

Free length

34.70 mm (1.37 in)

Limit

32.97 mm (1.30 in)

Relief valve spring

Free length

28.95 mm (1.14 in)

Limit

27.50 mm (1.08 in)

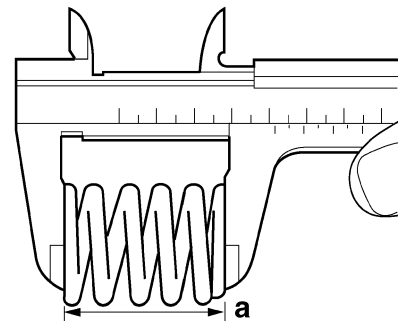

- a. Free length

2. Measure:

- Ball spring force
 - Relief valve spring force
- Out of specification → Replace the defective part(s).



Ball spring

Installed compression spring force

2.23 N (0.60 lb) (0.27 kgf) or less

Installed length

29.4 mm (1.12 in)

Relief valve spring

Installed compression spring force

52.4 N (11.78 lb) (5.34 kgf) or less

Installed length

16.8 mm (0.66 in)

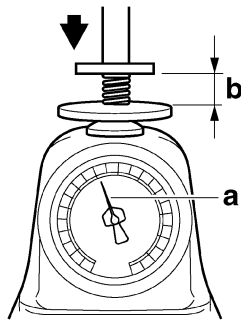

- a. Spring force
- b. Installed length

EAS24990

CHECKING THE OIL STRAINER

1. Check:

- Oil strainer “1”
- Damage → Replace.
Contaminants → Clean with solvent.

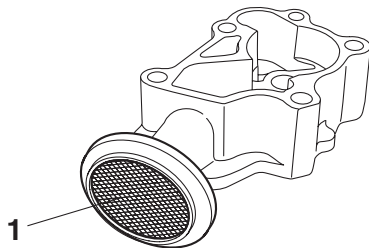

EAS25000

ASSEMBLING THE OIL PUMP

1. Lubricate:

- Inner rotor
- Outer rotor

- Oil pump shaft
(with the recommended lubricant)



Recommended lubricant
Engine oil

2. Install:

- Oil pump housing 2 “1”
- Ball guide “2”
- Ball “3”
- Oil seal “4” **New**
- Circlip “5” **New**
- Oil seal “6” **New**
- Oil pump shaft “7”
- Pin “8”
- Oil feed pump inner rotor “9”
- Oil feed pump outer rotor “10”
- Relief valve “11”
- Relief valve spring “12”
- Oil pump housing cover 2 “13”



Oil pump housing cover 2 screw
7 Nm (0.7 m·kg, 5.1 ft·lb)

- Pin “14”
- Oil scavenging pump inner rotor 2 “15”
- Oil scavenging pump outer rotor 2 “16”
- Ball spring “17”
- Pins “18”
- Oil strainer “19”
- Oil pump housing 1 “20”
- Pin “21”
- Oil scavenging pump inner rotor 1 “22”
- Oil scavenging pump outer rotor 1 “23”
- Oil pump housing cover 1 “24”



Oil pump housing cover 1 screw
7 Nm (0.7 m·kg, 5.1 ft·lb)

NOTE:

When installing the inner rotor, align the pin in the oil pump shaft with the groove in the inner rotor.

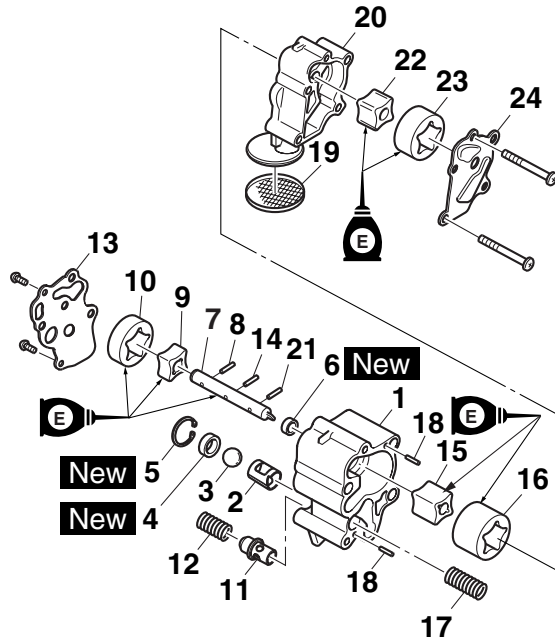

3. Check:

- Oil pump operation
Refer to "CHECKING THE OIL PUMP" on page 5-103.

EAS25020

INSTALLING THE OIL PUMP

1. Install:

- Oil pump assembly "1"



Oil pump assembly bolt
24 Nm (2.4 m·kg, 17 ft·lb)

ECA13890

CAUTION:

After tightening the bolts, make sure the oil pump turns smoothly.

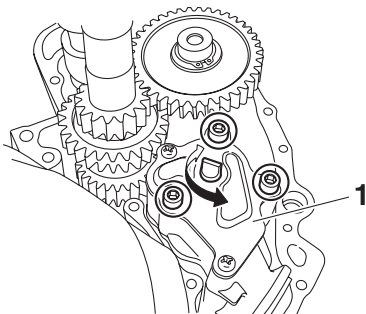

EAS25960

CRANKSHAFT

Removing the crankshaft

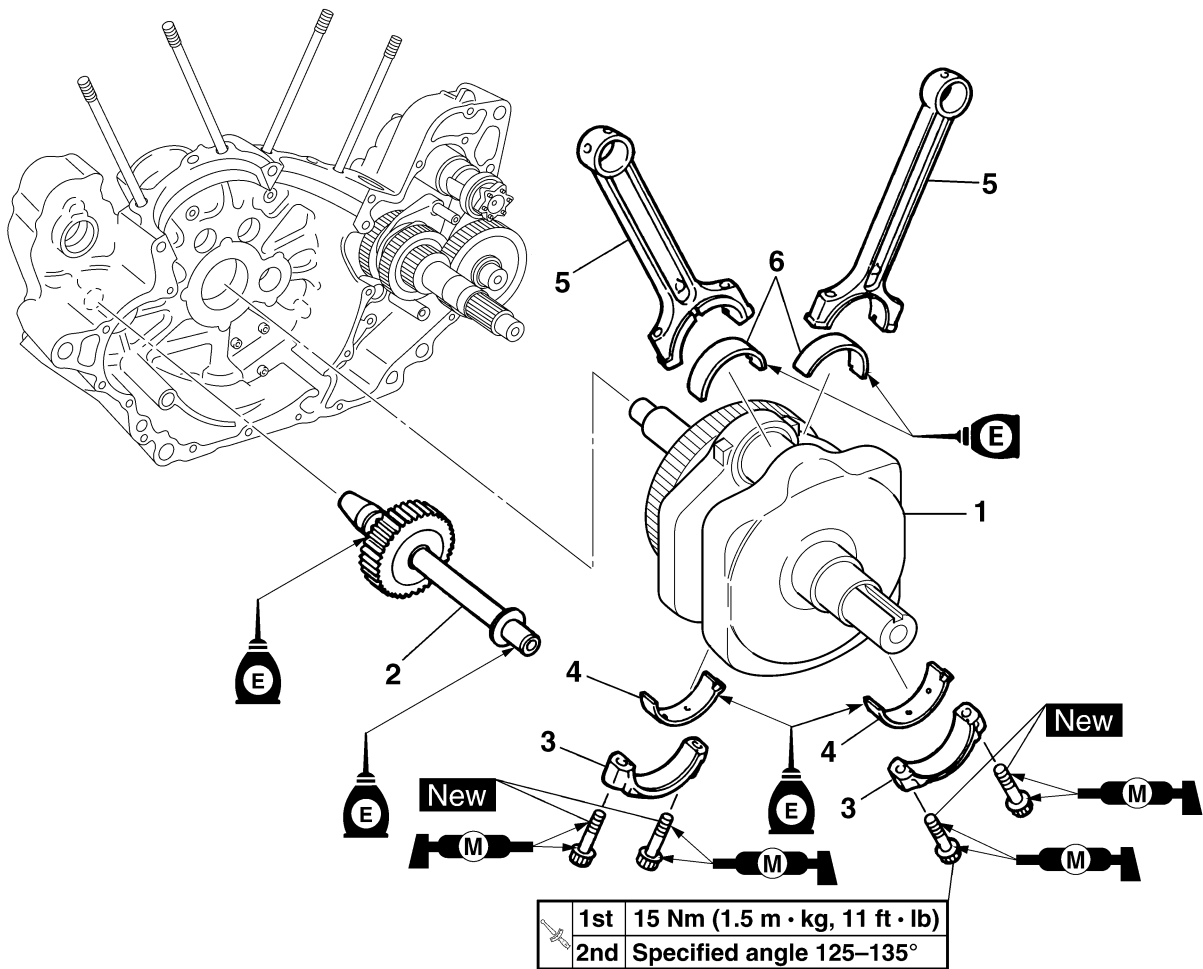

Order	Job/Parts to remove	Q'ty	Remarks
	Crankcase		Separate. Refer to "CRANKCASE" on page 5-94.
1	Crankshaft	1	
2	Generator shaft	1	
3	Connecting rod cap	2	
4	Big end lower bearing	2	
5	Connecting rod	2	
6	Big end upper bearing	2	
			For installation, reverse the removal procedure.

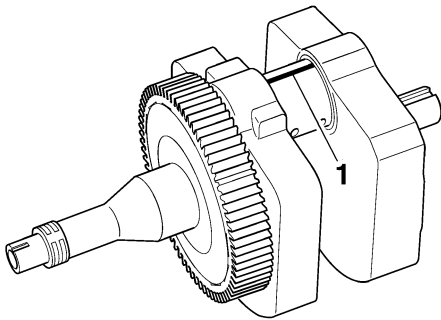

d. Assemble the connecting rod halves.

NOTE:

- Do not move the connecting rod or crankshaft until the clearance measurement has been completed.
- Lubricate the bolts threads with molybdenum disulfide grease.
- Make sure the projection “c” on the connecting rod faces towards the left side of the crankshaft.
- Make sure the characters “d” on both the connecting rod and connecting rod cap are aligned.

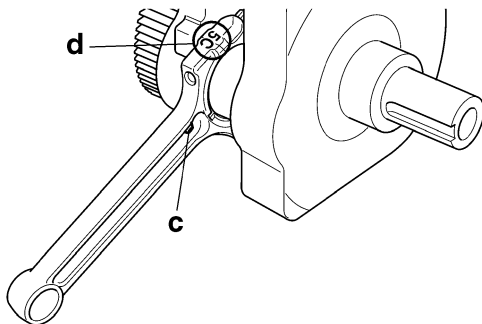

e. Tighten the connecting rod bolts.

EWA12890

WARNING

- Replace the connecting rod bolts with new ones.
- Clean the connecting rod bolts.

NOTE:

The tightening procedure of the connecting rod bolts is angle controlled, therefore tighten the bolts using the following procedure.

f. Tighten the connecting rod bolts to the specified torque.



Connecting rod bolt (1st)
15 Nm (1.5 m·kg, 11 ft·lb)

g. Put a mark “1” on the connecting rod bolts “2” and the connecting rod cap “3”.

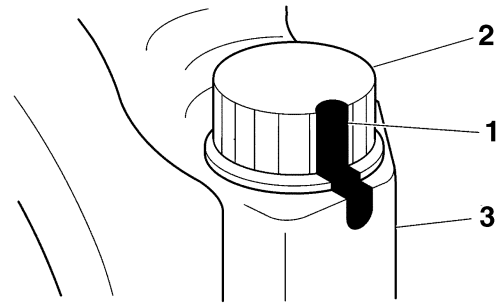

h. Tighten the connecting rod bolts further to reach the specified angle 125–135°.

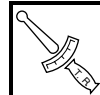

Connecting rod bolt (final)
Specified angle 125–135°

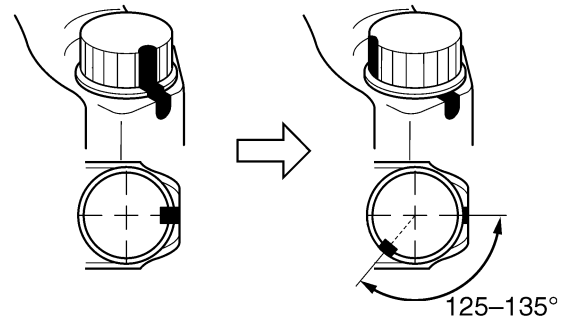

EW1D71011

WARNING

When a bolt is tightened more than the specified angle, do not loosen and then retighten it.

Replace the bolt with a new one and perform the procedure again.

EC1D71001

CAUTION:

- Do not use a torque wrench to tighten the bolt to the specified angle.
- Tighten the bolt until it is at the specified angle.

- Remove the connecting rod and big end bearings.
- Measure the compressed Plastigauge® width “e” on the crankshaft pin. If the crankshaft-pin-to-big-end-bearing clearance is out of specification, select replacement big end bearings.

CRANKSHAFT

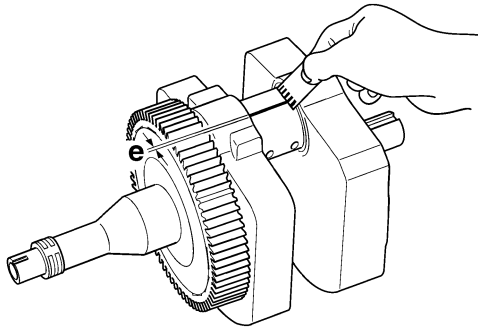

4. Select:

- Big end bearings (“P₁”-“P₂”)

NOTE:

- The numbers “a” stamped into the crankshaft web and the numbers “b” on the connecting rods are used to determine the replacement big end bearing sizes.
- “P₁”-“P₂” refer to the bearings shown in the crankshaft illustration.

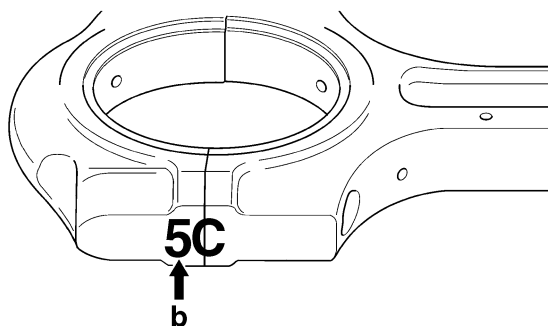
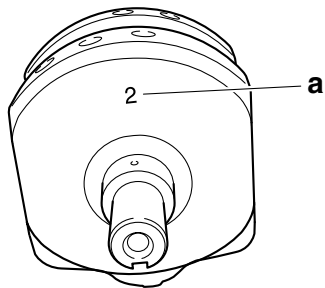
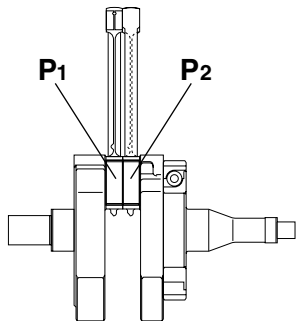

For example, if the connecting rod “P₁” and the crankshaft web “P” numbers are “5” and “2” respectively, then the bearing size for “P₁” is:

$$\begin{aligned} & \text{“P}_1\text{” (connecting rod) - “P” (crankshaft)} \\ & = \\ & 5 - 2 = 3 \text{ (brown)} \end{aligned}$$



Bearing color code

1. Blue 2. Black 3. Brown 4. Green
5. Yellow

5. Measure:

- Crankshaft journal diameter “a”
Out of specification → Replace the crankshaft.

NOTE:

Measure the diameter of each crankshaft journal at two places.



Crankshaft journal diameter
49.968–49.980 mm (1.9672–1.9677 in)

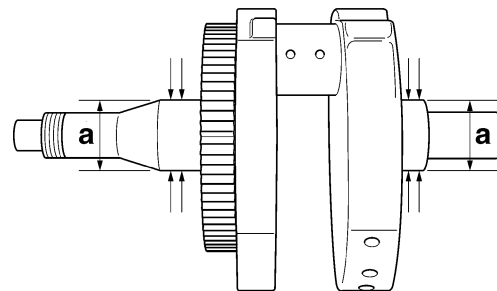

6. Measure:

- Crankshaft journal bearing inside diameter “a”
Out of specification → Replace the crankcase assembly.

NOTE:

Measure the inside diameter of each crankshaft journal bearing at two places.



Crankshaft journal bearing inside diameter
50.010–50.030 mm (1.9689–1.9697 in)

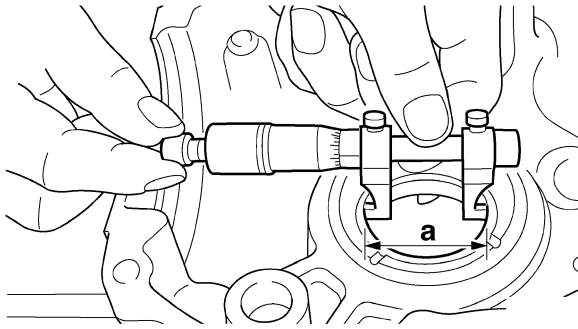

EAS26150

INSTALLING THE CONNECTING RODS

1. Lubricate:

- Bolt threads
(with the recommended lubricant)

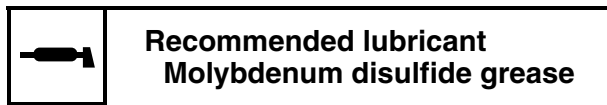

2. Lubricate:

- Crankshaft pins
- Big end bearings
- Connecting rod inner surface
(with the recommended lubricant)



3. Install:

- Big end bearings
- Connecting rods
- Connecting rod caps
(onto the crankshaft pins)

NOTE:

- Align the projections “a” on the big end bearings with the notches “b” in the connecting rods and connecting rod caps.
- Be sure to reinstall each big end bearing in its original place.
- Make sure the projection “c” on the connecting rods face towards the left side of the crankshaft.
- Make sure the characters “d” on both the connecting rod and connecting rod cap are aligned.

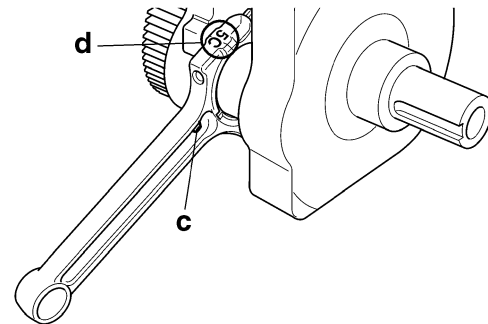
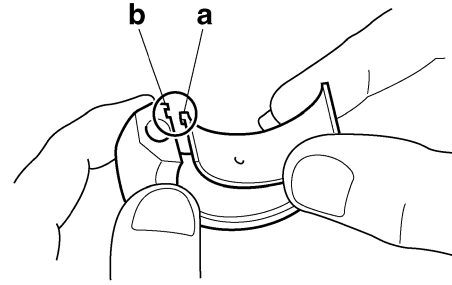

4. Tighten:

- Connecting rod bolts “1”

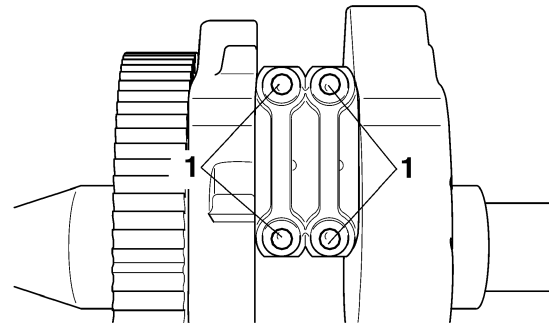

EWA12890

WARNING

- Replace the connecting rod bolts with new ones.
- Clean the connecting rod bolts.

NOTE:

The tightening procedure of the connecting rod bolts is angle controlled, therefore tighten the bolts using the following procedure.

- Tighten the connecting rod bolts with a torque wrench.



**Connecting rod bolt (1st)
15 Nm (1.5 m·kg, 11 ft·lb)**

- Put a mark “1” on the corner of the connecting rod bolts “2” and the connecting rod “3”.

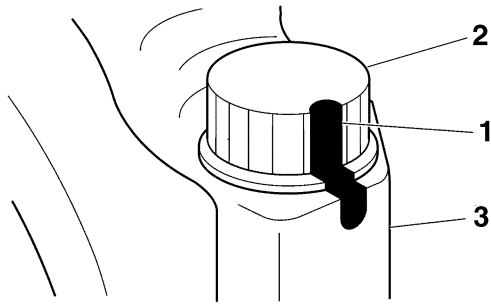

c. Tighten the connecting rod bolts further to reach the specified angle 125–135°.

Connecting rod bolt (final)
Specified angle 125–135°

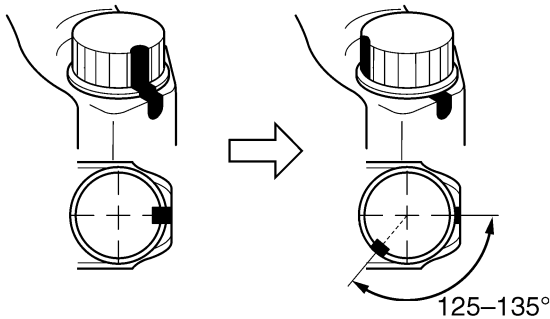

NOTE: _____

- Make sure that the generator shaft drive gear teeth and generator shaft driven gear teeth mesh correctly.
- Align the punch mark “a” on the generator shaft driven gear with the punch mark “b” on the generator shaft drive gear.
- Align the right connecting rod with the front cylinder sleeve hole.

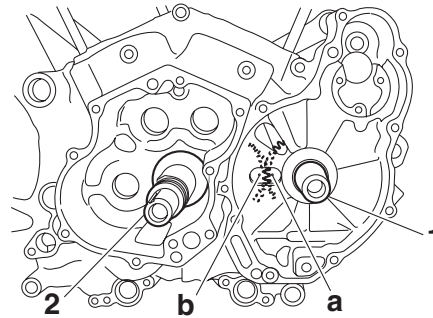

EW1D71011

WARNING

When a bolt is tightened more than the specified angle, do not loosen and then retighten it.

Replace the bolt with a new one and perform the procedure again.

EC1D71001

CAUTION: _____

- Do not use a torque wrench to tighten the bolt to the specified angle.
- Tighten the bolt until it is at the specified angle.



EAS26210

INSTALLING THE CRANKSHAFT ASSEMBLY

1. Install:
 - Generator shaft “1”
 - Crankshaft assembly “2”

ECA13970

CAUTION: _____

To avoid scratching the crankshaft and to ease the installation procedure, lubricate the oil seal lips with lithium-soap-based grease and each bearing with engine oil.

Disassembling the main axle assembly

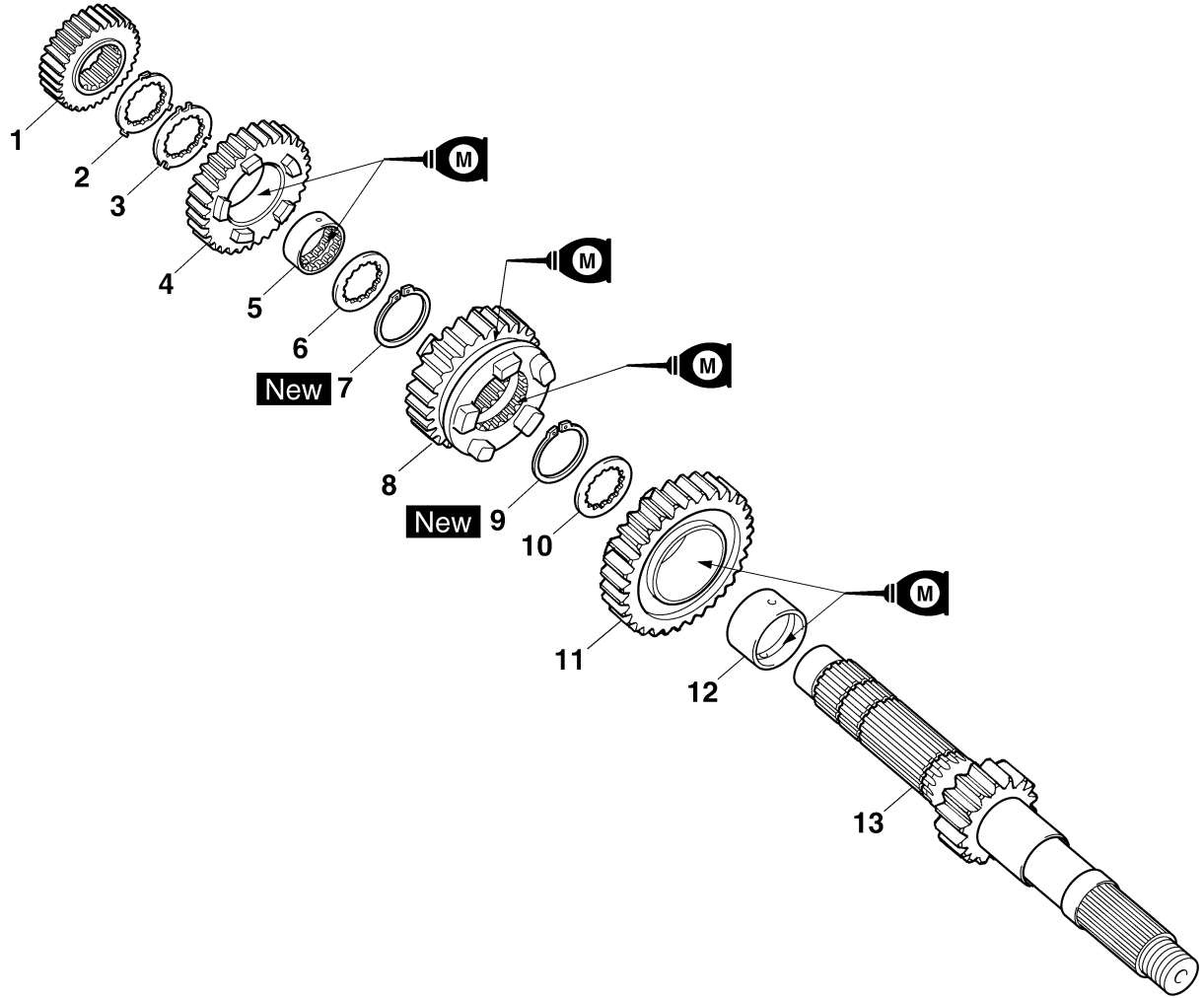

Order	Job/Parts to remove	Q'ty	Remarks
1	2nd pinion gear	1	
2	Toothed lock washer	1	
3	Toothed lock washer retainer	1	
4	5th pinion gear	1	
5	Collar	1	
6	Toothed washer	1	
7	Circlip	1	
8	3rd pinion gear	1	
9	Circlip	1	
10	Toothed washer	1	
11	4th pinion gear	1	
12	Collar	1	
13	Main axle/1st pinion gear	1	
			For assembly, reverse the disassembly procedure.

Disassembling the drive axle assembly

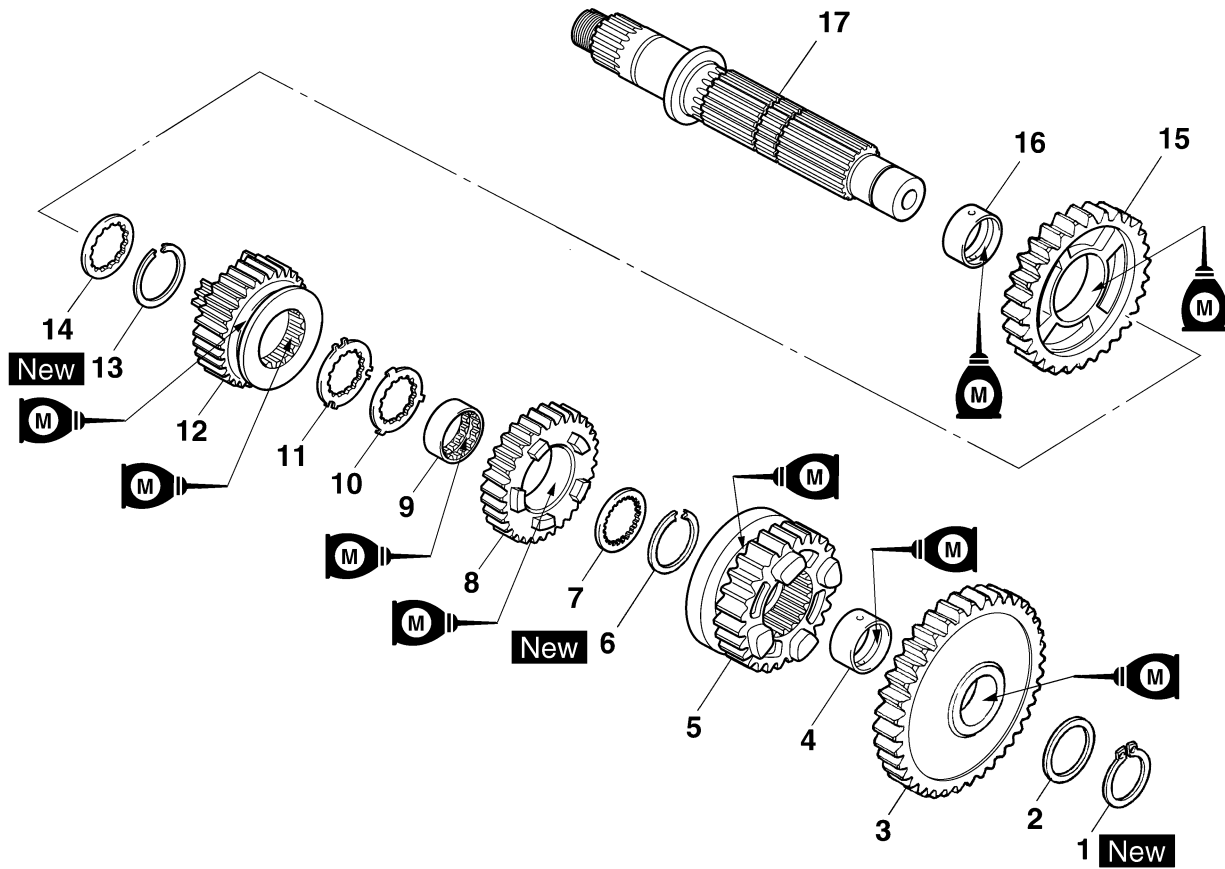

Order	Job/Parts to remove	Q'ty	Remarks
1	Circlip	1	
2	Washer	1	
3	1st wheel gear	1	
4	Collar	1	
5	4th wheel gear	1	
6	Circlip	1	
7	Toothed washer	1	
8	3rd wheel gear	1	
9	Collar	1	
10	Toothed lock washer	1	
11	Toothed lock washer retainer	1	
12	5th wheel gear	1	
13	Circlip	1	
14	Toothed washer	1	
15	2nd wheel gear	1	
16	Collar	1	

Disassembling the drive axle assembly

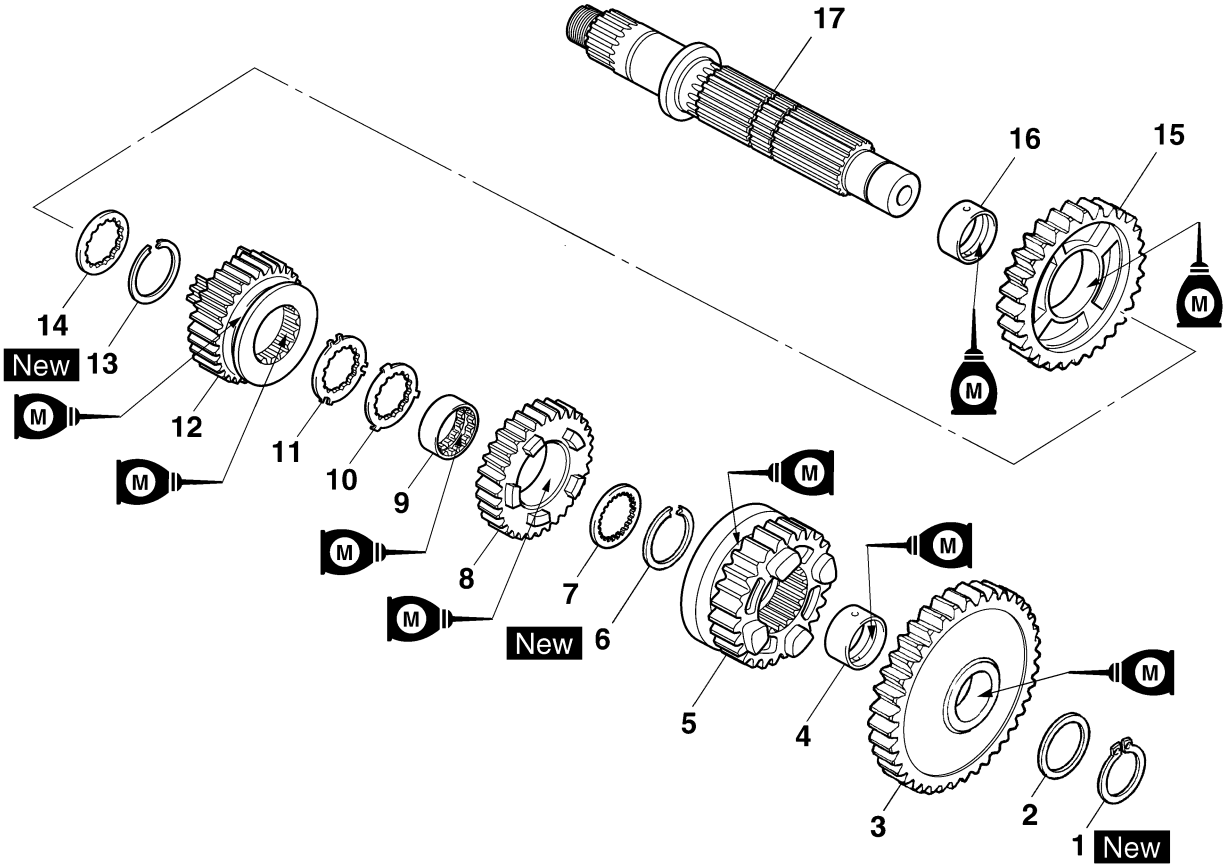

Order	Job/Parts to remove	Q'ty	Remarks
17	Drive axle	1	
			For assembly, reverse the disassembly procedure.

EAS26260

CHECKING THE SHIFT FORKS

The following procedure applies to all of the shift forks.

1. Check:

- Shift fork cam follower “1”
- Shift fork pawl “2”

Bends/damage/scoring/wear → Replace the shift fork.

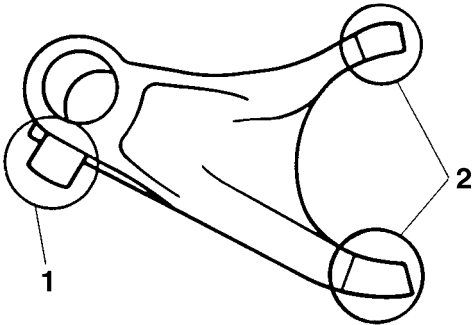

2. Check:

- Shift fork guide bar

Roll the shift fork guide bar on a flat surface.

Bends → Replace.

EWA12840

WARNING

Do not attempt to straighten a bent shift fork guide bar.

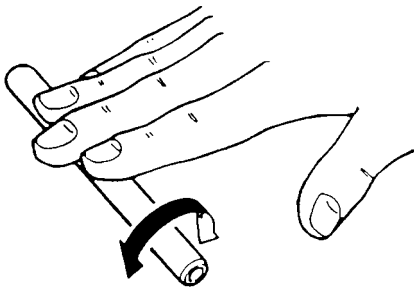

3. Check:

- Shift fork movement (along the shift fork guide bar)

Rough movement → Replace the shift forks and shift fork guide bar as a set.

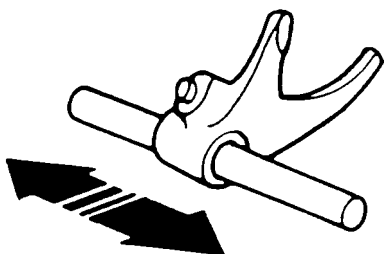

EAS26270

CHECKING THE SHIFT DRUM ASSEMBLY

1. Check:

- Shift drum groove
Damage/scratches/wear → Replace the shift drum assembly.
- Shift drum segment “1”
Damage/wear → Replace the shift drum assembly.
- Shift drum bearing “2”
Damage/pitting → Replace the shift drum assembly.

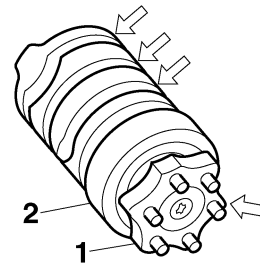

EAS26300

CHECKING THE TRANSMISSION

1. Measure:

- Main axle runout (with a centering device and dial gauge “1”) Out of specification → Replace the main axle.



**Main axle runout limit
0.08 mm (0.0032 in)**

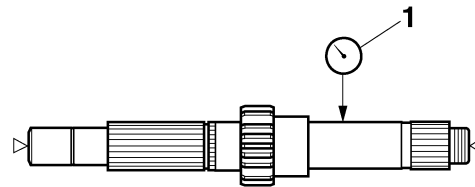

2. Measure:

- Drive axle runout (with a centering device and dial gauge “1”) Out of specification → Replace the drive axle.



**Drive axle runout limit
0.08 mm (0.0032 in)**

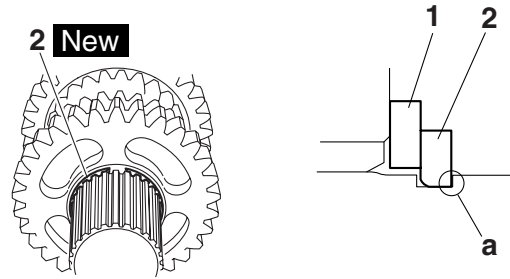
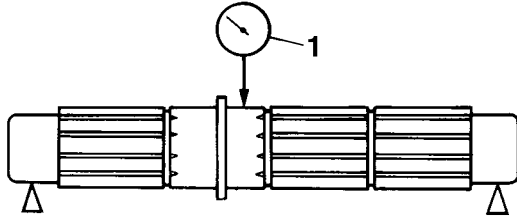

3. Check:

- Transmission gears
Blue discoloration/pitting/wear → Replace the defective gear(s).
- Transmission gear dogs
Cracks/damage/rounded edges → Replace the defective gear(s).

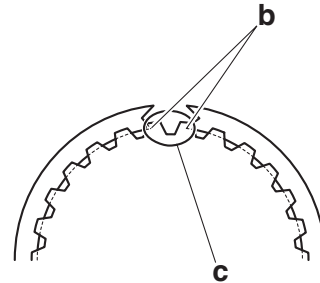
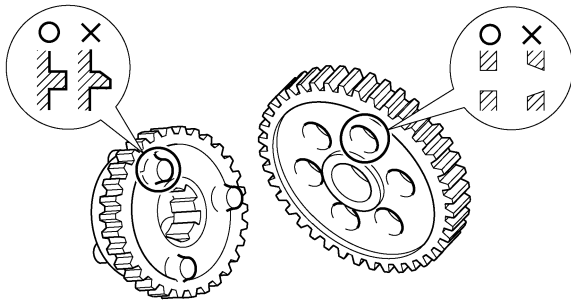

2. Install:

- Toothed lock washer retainer "1"
- Toothed lock washer "2"

NOTE:

- With the toothed lock washer retainer "1" in the groove "a" in the axle, align the projection "c" on the retainer with an axle spline "b", and then install the toothed lock washer "2".
- Be sure to align the projection on the toothed lock washer that is between the alignment marks "e" with the alignment mark "d" on the retainer.

4. Check:

- Transmission gear engagement (each pinion gear to its respective wheel gear)
Incorrect → Reassemble the transmission axle assemblies.

5. Check:

- Transmission gear movement
Rough movement → Replace the defective part(s).

6. Check:

- Circlips
Bends/damage/looseness → Replace.

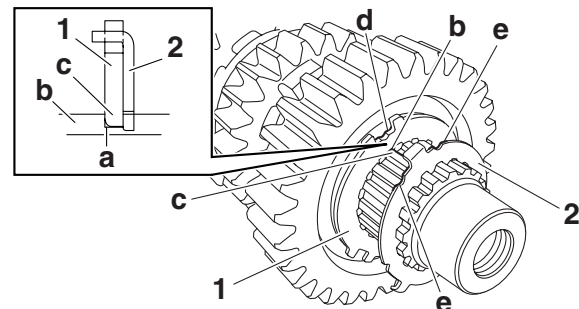

ET1D71006

ASSEMBLING THE MAIN AXLE AND DRIVE AXLE

1. Install:

- Toothed washer "1"
- Circlip "2" **New**

NOTE:

- Be sure the circlip sharp-edged corner "a" is positioned opposite side to the toothed washer and gear. (for main axle)
- Install the circlip so that both ends "b" rest on the sides of a spline "c" with both axles aligned.

EAS26320

INSTALLING THE SHIFT FORKS AND SHIFT DRUM ASSEMBLY

1. Install:

- Shift forks 1 "1"
- Shift fork 2 "2"
- Shift drum assembly "3"
- Shift fork guide bars "4"

NOTE:

The embossed marks “1D7” on the shift forks should face towards the left side of the engine.

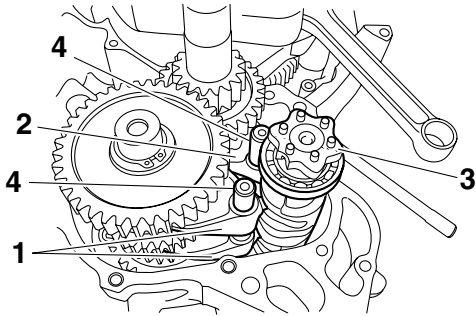

2. Check:

- Transmission
Rough movement → Repair.

NOTE:

- Apply engine oil to each gear and bearing thoroughly.
- Before assembling the crankcase, make sure that the transmission is in neutral and that the gears turn freely.

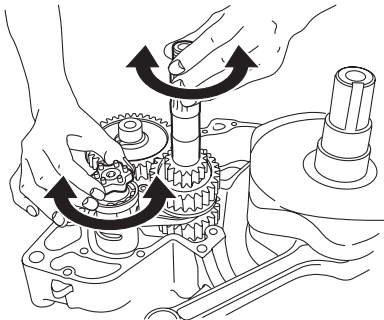

FUEL SYSTEM

FUEL TANK	6-1
REMOVING THE FUEL TANK	6-4
REMOVING THE FUEL PUMP	6-4
CHECKING THE FUEL PUMP BODY.....	6-5
CHECKING THE FUEL PUMP OPERATION.....	6-5
INSTALLING THE FUEL PUMP.....	6-5
INSTALLING THE FUEL TANK.....	6-5
THROTTLE BODIES	6-7
REMOVING THE FUEL HOSE	6-15
CHECKING THE INJECTORS.....	6-15
CHECKING THE THROTTLE BODIES.....	6-15
CHECKING THE ROLLOVER VALVES.....	6-15
CHECKING THE PRESSURE REGULATOR	6-15
CHECKING THE PRESSURE REGULATOR OPERATION	6-15
ADJUSTING THE THROTTLE POSITION SENSOR.....	6-16
INSTALLING THE FUEL PIPE	6-16
INSTALLING THE FUEL HOSE	6-17
ISC (IDLE SPEED CONTROL) UNIT	6-18
CHECKING THE ISC (IDLE SPEED CONTROL) SYSTEM	6-19

EAS26620

FUEL TANK

Removing the fuel tank

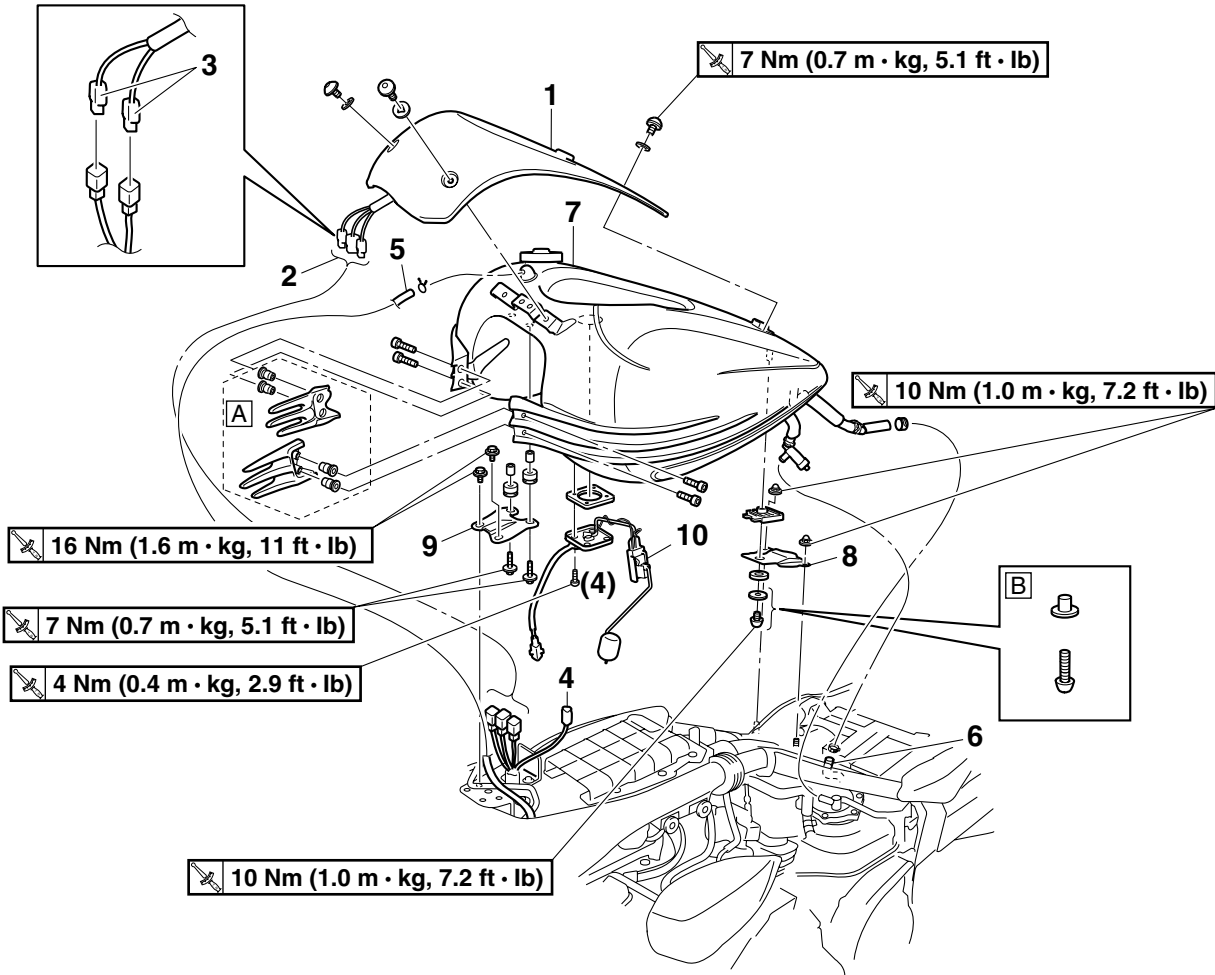

Order	Job/Parts to remove	Q'ty	Remarks
	Rider seat/Rider seat bracket		Refer to "GENERAL CHASSIS" on page 4-1.
1	Meter cover	1	
2	Meter assembly coupler	3	Disconnect. For XV19S(C)/ XV19M(C)/ XV19CTS(C)/ XV19CTM(C)
3	Meter assembly coupler	2	Disconnect. For XV19CS(C)/ XV19C(C)
4	Fuel sender coupler	1	Disconnect.
5	Fuel tank breather hose	1	Disconnect.
6	Air vent hose (fuel pump to fuel hose joint)	1	Disconnect.
7	Fuel tank	1	
8	Fuel tank bracket (rear side)	1	
9	Fuel tank bracket (front side)	1	

Removing the fuel tank

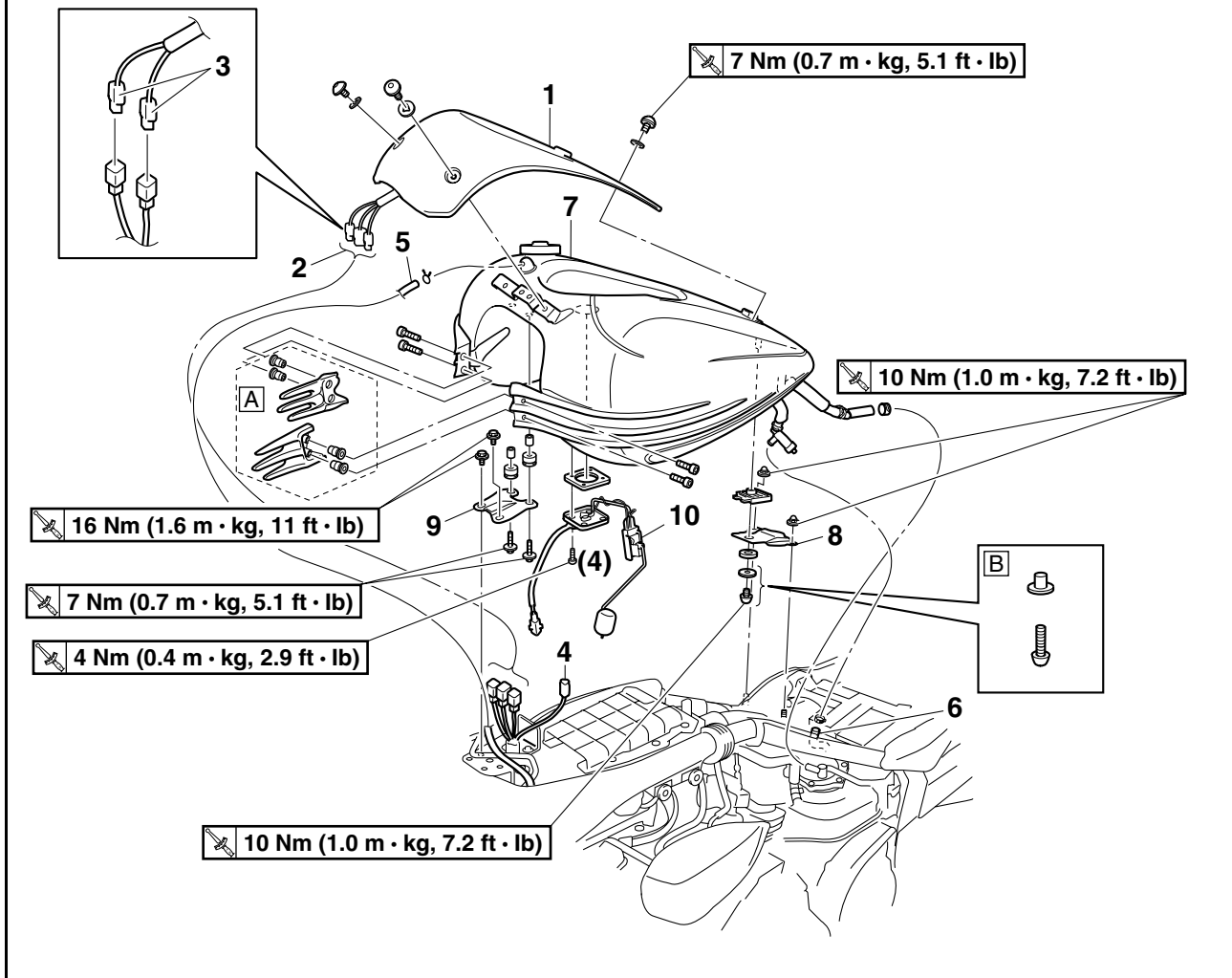

Order	Job/Parts to remove	Q'ty	Remarks
10	Fuel sender	1	
			For installation, reverse the removal procedure.

A: For XV19S(C)/ XV19M(C)/ XV19CTS(C)/ XV19CTM(C)

B: For XV19CS(C)/ XV19C(C)

Removing the fuel pump and sub-fuel tank

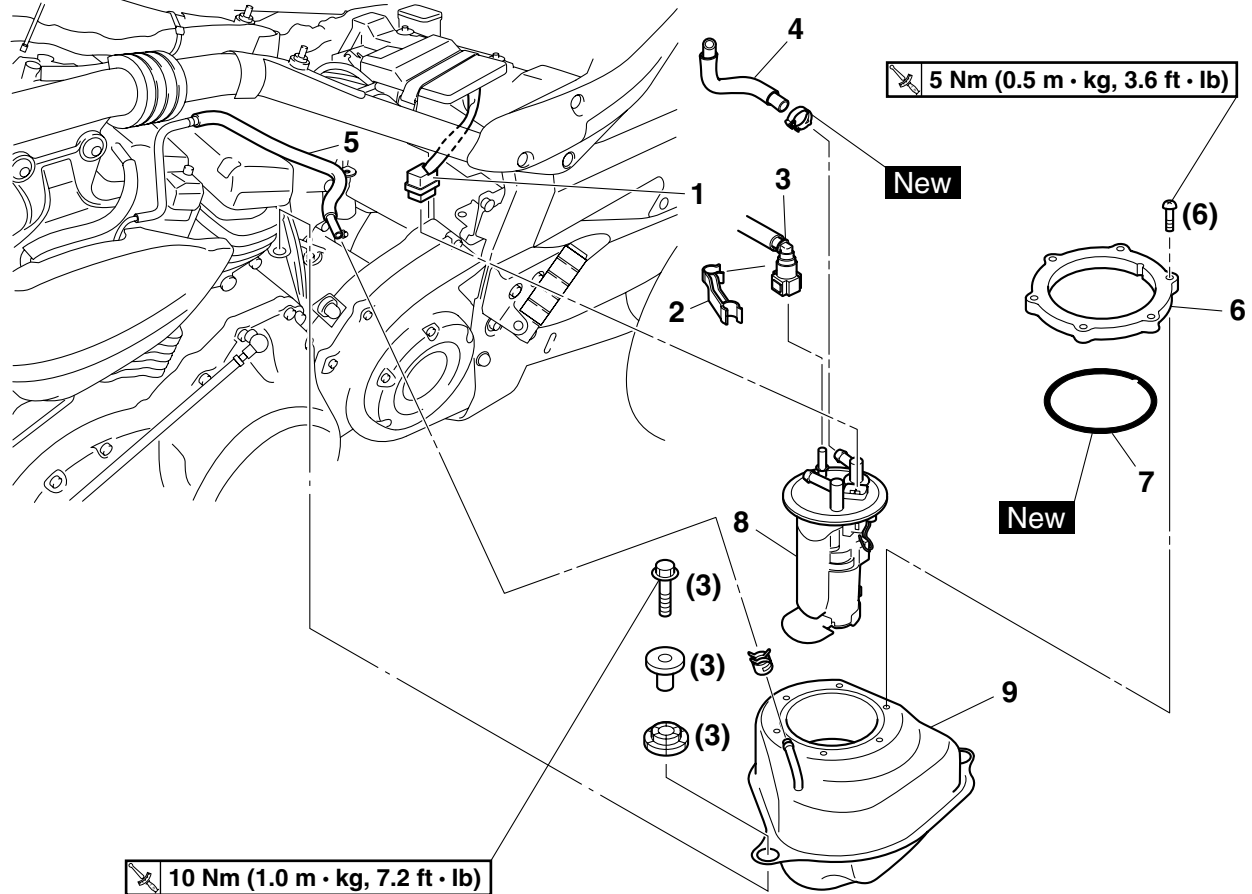

Order	Job/Parts to remove	Q'ty	Remarks
	Rider seat/Rider seat bracket		Refer to "GENERAL CHASSIS" on page 4-1.
	Fuel tank		Refer to "FUEL TANK" on page 6-1.
1	Fuel pump coupler	1	Disconnect.
2	Fuel hose connector cover	1	
3	Fuel outlet hose	1	Disconnect.
4	Air vent hose (fuel pump to fuel hose joint)	1	
5	Fuel return hose (fuel return pipe to sub-fuel tank)	1	Disconnect.
6	Fuel pump bracket	1	
7	Fuel pump gasket	1	
8	Fuel pump	1	
9	Sub-fuel tank	1	
			For installation, reverse the removal procedure.

EAS26630

REMOVING THE FUEL TANK

1. Extract the fuel in the fuel tank through the fuel tank cap with a pump.
2. Remove:
 - Fuel tank

EC1D71021

CAUTION:

Although the fuel has been removed from the fuel tank, be careful when removing the fuel hoses, since there may be fuel remaining in them.

- a. Remove the fuel hose joint caps "1".

NOTE:

After removing the fuel hose joint caps, clean the projection on each cap so that no foreign material will enter the fuel lines.

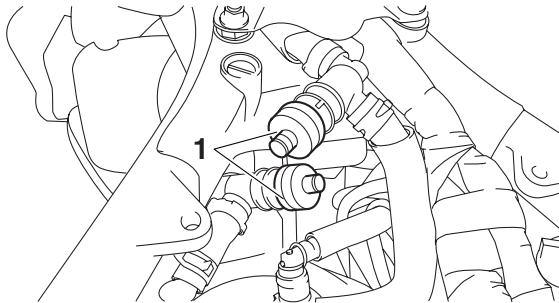

- b. Lubricate the O-ring "1" with the recommended silicone lubricant "2".



Recommended lubricant
Silicone protectant and lubricant
ACC-SLCNS-PR-AY

NOTE:

Spray the silicone lubricant in the areas shown in the illustration.

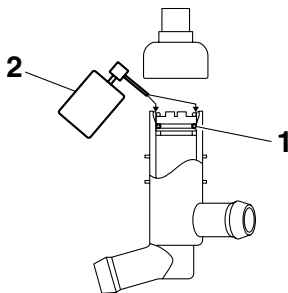

- c. Turn the screws "1" clockwise.

NOTE:

Turn the screws until they stop.

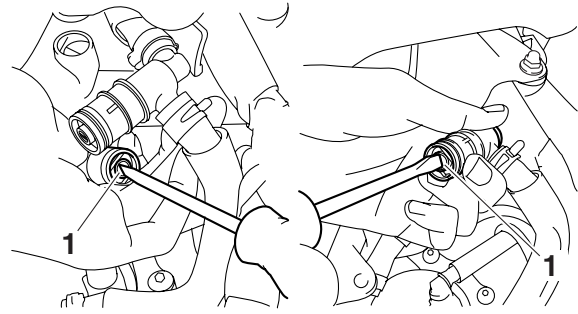

- d. Disconnect the fuel hose (fuel hose joint to fuel pump) "1" and air vent hose (fuel pump to fuel hose joint) "2".

NOTE:

Before removing the hoses, place a few rags in the area under where they will be removed.

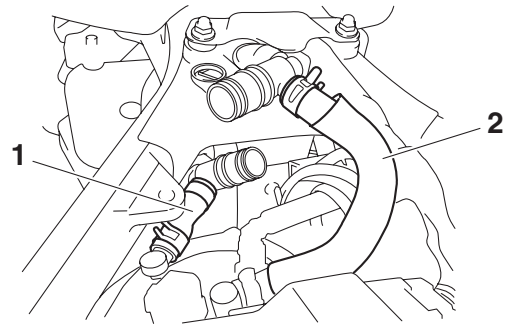

- e. Install the fuel hose joint cap "1" and rubber plug "2".

NOTE:

Insert the projection on the fuel hose joint cap completely into the pipe of the fuel hose joint and insert the rubber plug into the end of the fuel hose (fuel hose joint to fuel pump).

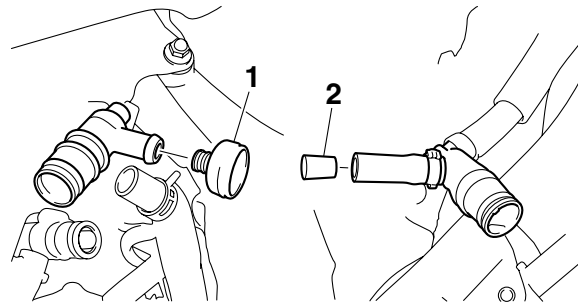

- f. Remove the fuel tank.



EAS26640

REMOVING THE FUEL PUMP

1. Remove:
 - Fuel hose connector cover
2. Disconnect:
 - Fuel outlet hose

- b. Remove the fuel hose joint caps.
- c. Connect the fuel hose (fuel hose joint to fuel pump) and air vent hose (fuel pump to fuel hose joint).
- d. Turn the screws "1" counterclockwise.

NOTE: _____

Turn the screws until they contact the clips "a".

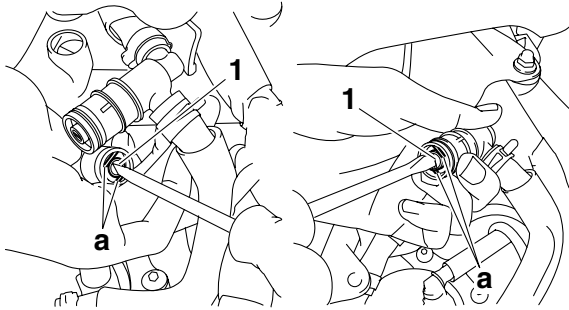

- e. Install the fuel hose joint caps.

NOTE: _____

Install the fuel hose joint caps completely onto the fuel hose joints.



2. Install: (for XV19S(C)/ XV19M(C)/ XV19CTS(C)/ XV19CTM(C))
 - Meter assembly couplers
 - Fuel sender coupler

NOTE: _____

Make sure that the couplers are positioned as shown in the illustration in the following order from left to right: fuel sender coupler "1", 6-pin black meter assembly coupler "2", 6-pin white meter assembly coupler "3", and 3-pin black meter assembly coupler "4".

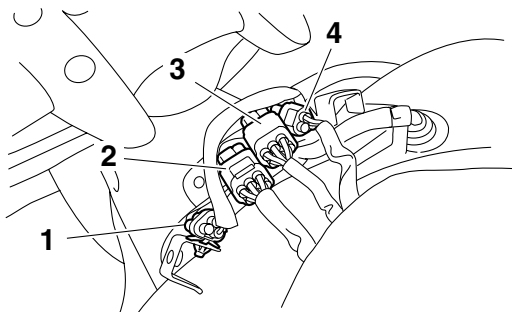

EAS26970

THROTTLE BODIES

Removing the rollover valves (for XV19S(C)/ XV19M(C)/ XV19CTS(C)/ XV19CTM(C))

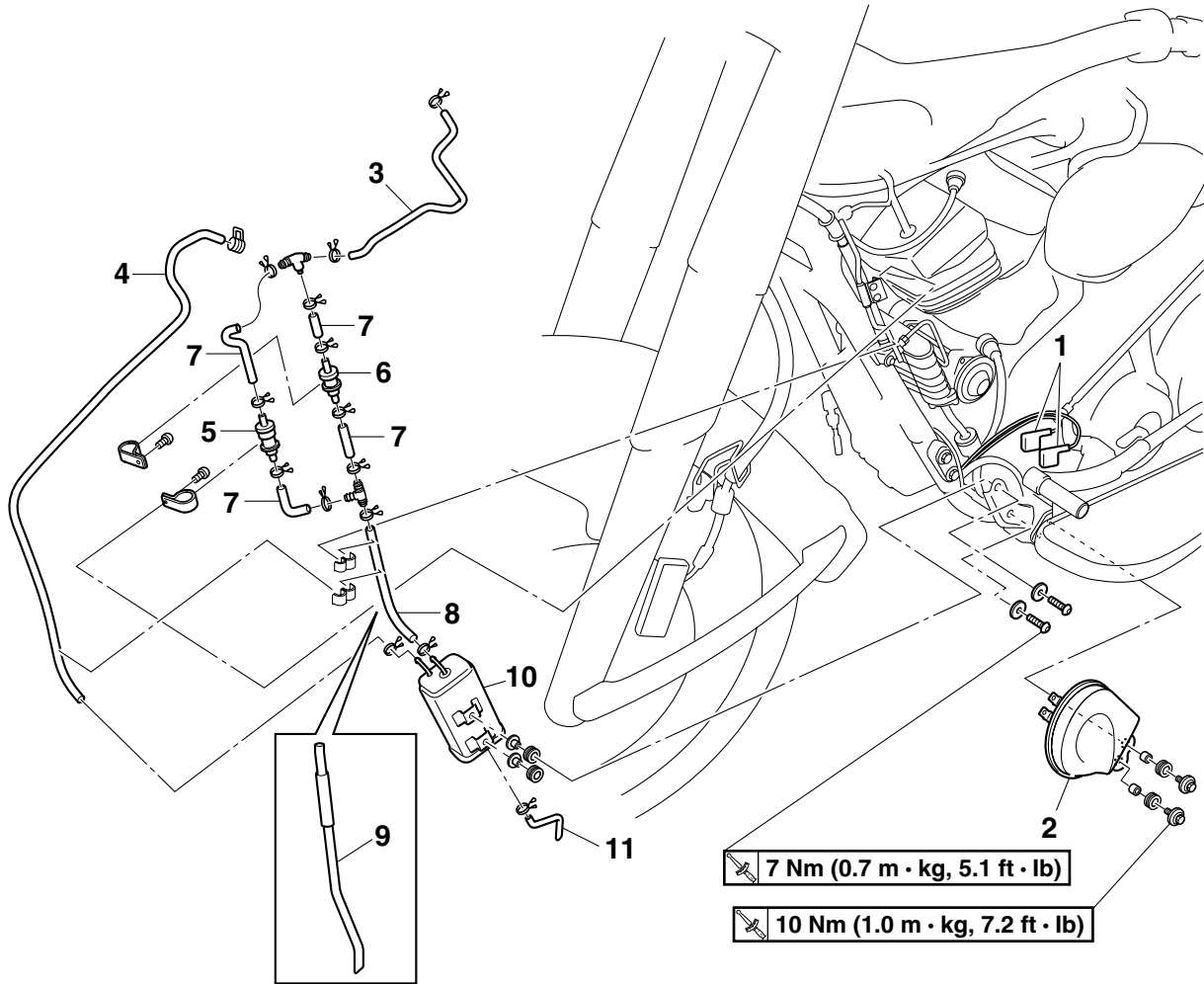

Order	Job/Parts to remove	Q'ty	Remarks
1	Horn 1 connector	2	For California only Disconnect.
2	Horn 1	1	For California only
3	Fuel tank breather hose	1	
4	Canister purge hose	1	For California only
5	Rollover valve 1	1	
6	Rollover valve 2	1	
7	Rollover valve hose	4	
8	Fuel tank breather/overflow hose	1	For California only
9	Fuel tank breather/overflow hose	1	Except for California
10	Canister	1	For California only
11	Canister breather hose	1	For California only
			For installation, reverse the removal procedure.

THROTTLE BODIES

Removing the rollover valves (for XV19CS/ XV19C)

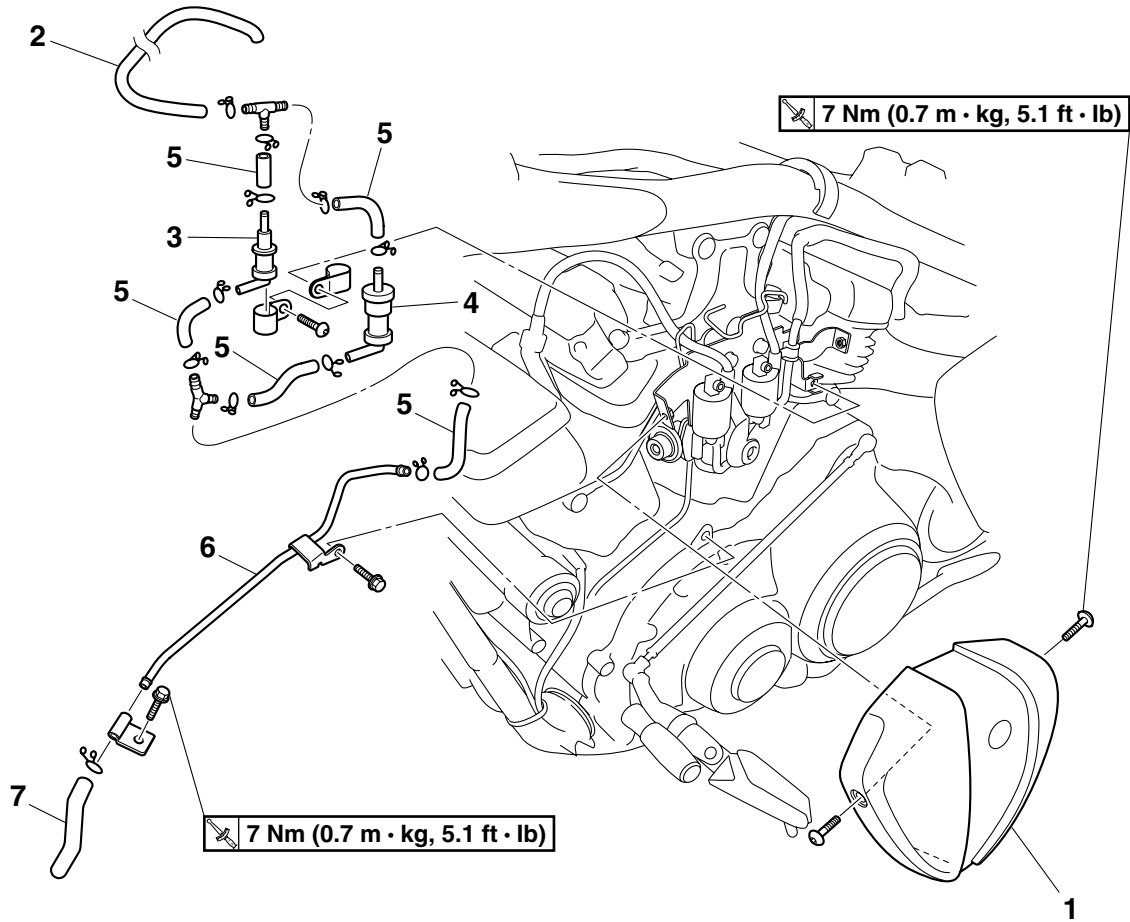

Order	Job/Parts to remove	Q'ty	Remarks
	Fuel tank		Refer to "FUEL TANK" on page 6-1.
	Air filter case		Refer to "GENERAL CHASSIS" on page 4-1.
1	Pressure regulator cover	1	
2	Fuel tank breather hose	1	
3	Rollover valve 1	1	
4	Rollover valve 2	1	
5	Rollover valve hose	5	
6	Fuel tank breather/overflow pipe	1	
7	Fuel tank breather/overflow hose	1	
			For installation, reverse the removal procedure.

THROTTLE BODIES

Removing the rollover valves (for california only) (for XV19CSC/ XV19CC)

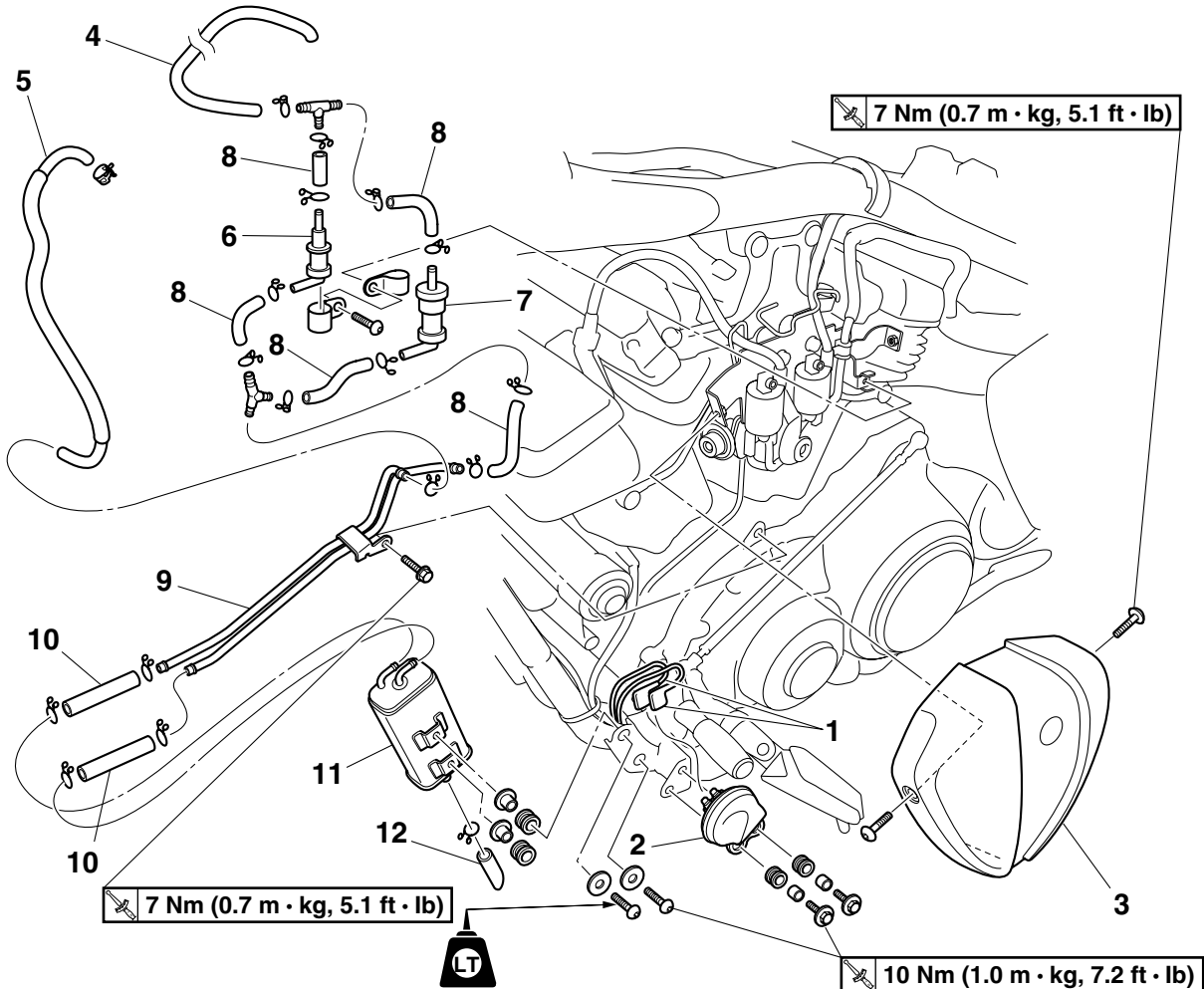

Order	Job/Parts to remove	Q'ty	Remarks
	Fuel tank		Refer to "FUEL TANK" on page 6-1.
	Air filter case		Refer to "GENERAL CHASSIS" on page 4-1.
1	Horn 1 connector	2	Disconnect.
2	Horn 1	1	
3	Pressure regulator cover	1	
4	Fuel tank breather hose	1	
5	Canister purge hose	1	
6	Rollover valve 1	1	
7	Rollover valve 2	1	
8	Rollover valve hose	4	
9	Fuel tank breather/overflow pipe	1	
10	Canister hose	2	
11	Canister	1	
12	Canister breather hose	1	
			For installation, reverse the removal procedure.

THROTTLE BODIES

Removing the pressure regulator (for XV19S(C)/ XV19M(C)/ XV19CTS(C)/ XV19CTM(C))

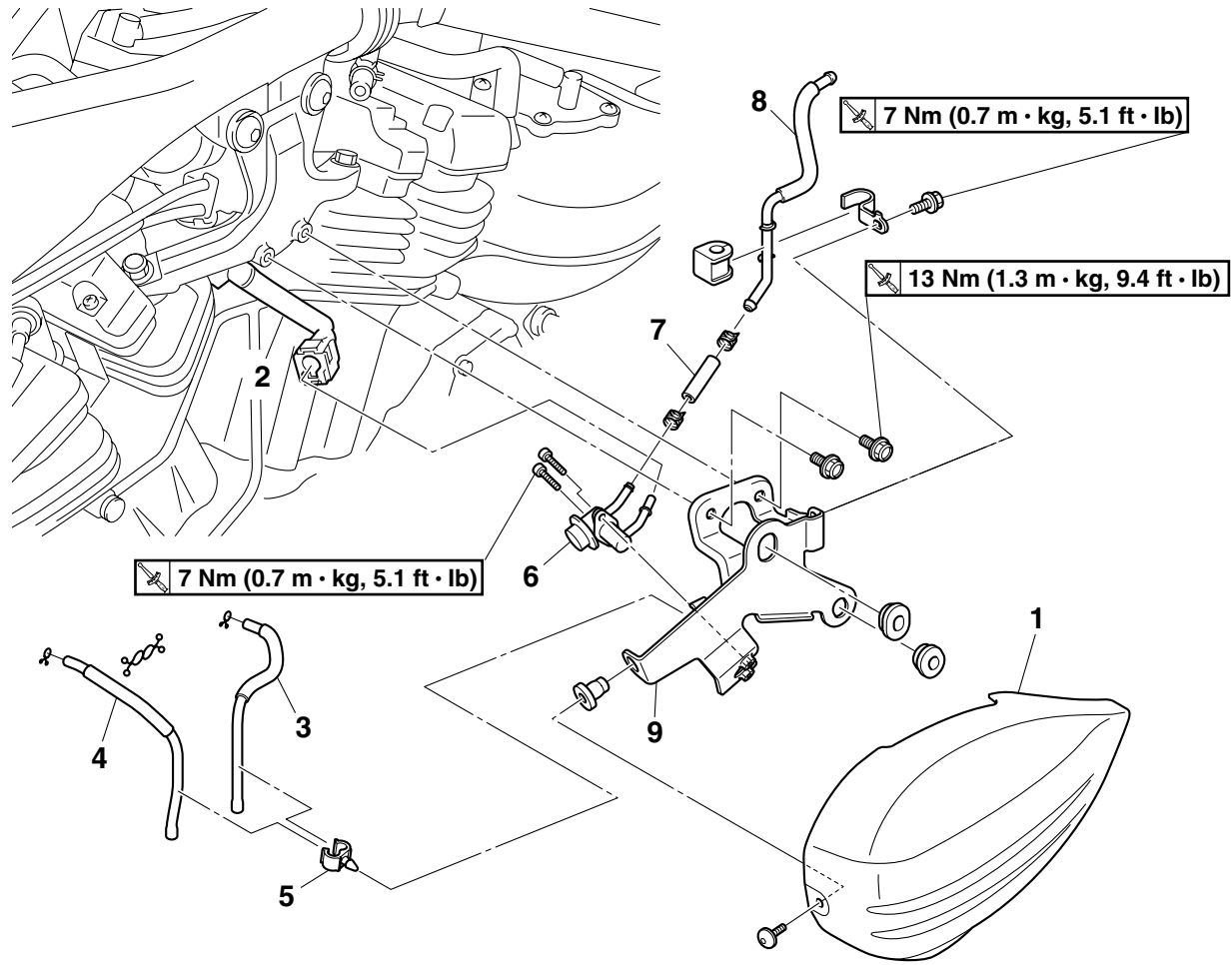

Order	Job/Parts to remove	Q'ty	Remarks
1	Pressure regulator cover	1	
2	Fuel hose (intake manifold assembly to pressure regulator)	1	
3	Air filter case breather hose 1	1	
4	Air filter case breather hose 2	1	
5	Hose clamp	1	
6	Pressure regulator	1	
7	Fuel return hose	1	
8	Fuel return pipe	1	
9	Pressure regulator bracket	1	
			For installation, reverse the removal procedure.

THROTTLE BODIES

Removing the left ignition coils and pressure regulator (for XV19CS(C)/ XV19C(C))

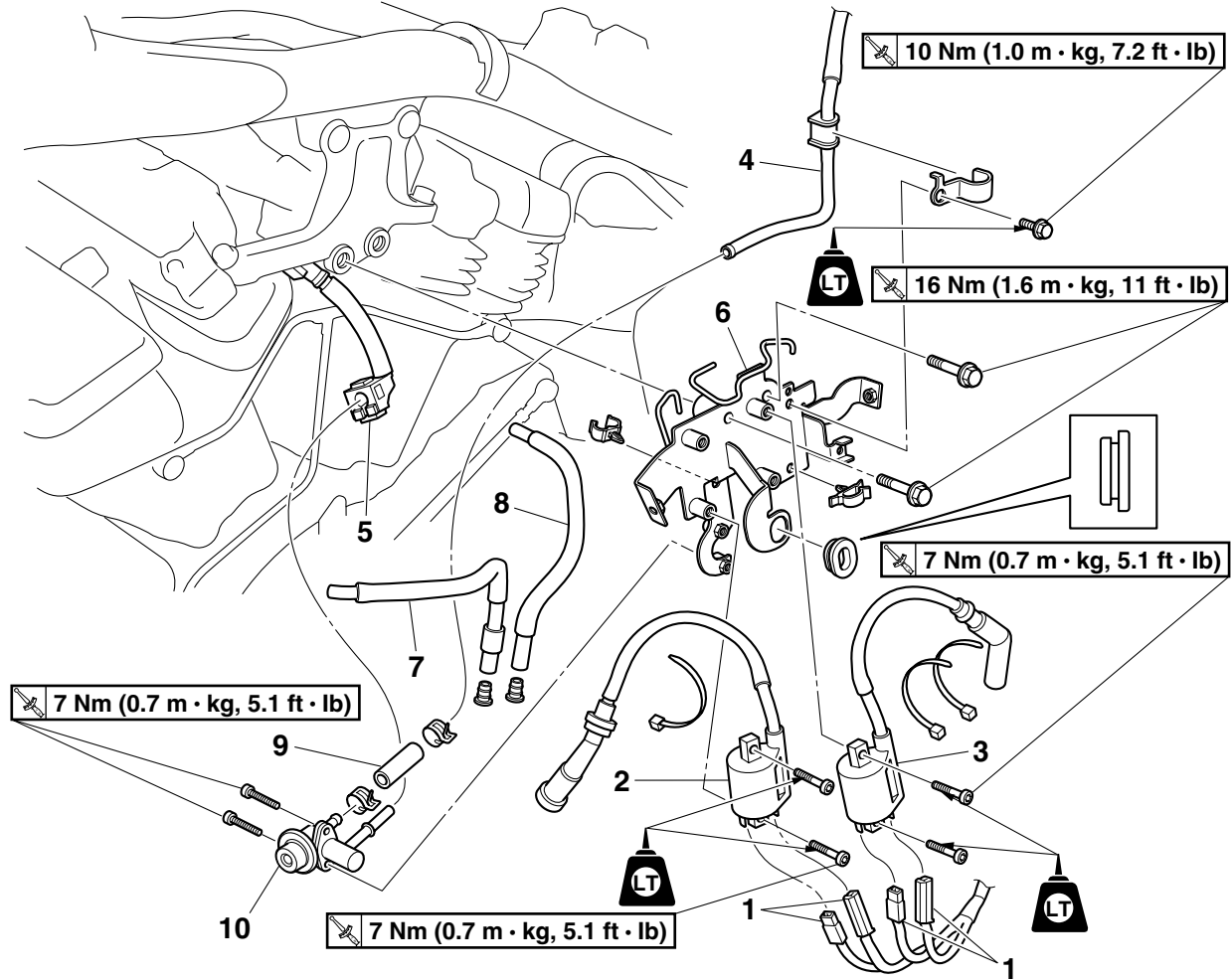

Order	Job/Parts to remove	Q'ty	Remarks
	Rollover valves		Refer to "THROTTLE BODIES" on page 6-7.
1	Ignition coil connector	4	Disconnect.
2	Cylinder-#2 left ignition coil	1	
3	Cylinder-#1 left ignition coil	1	
4	Fuel return pipe	1	
5	Fuel hose (intake manifold assembly to pressure regulator)	1	Disconnect.
6	Pressure regulator bracket	1	
7	Air filter case breather hose 1	1	
8	Air filter case breather hose 2	1	
9	Fuel return hose	1	
10	Pressure regulator	1	
			For installation, reverse the removal procedure.

THROTTLE BODIES

Removing the throttle bodies

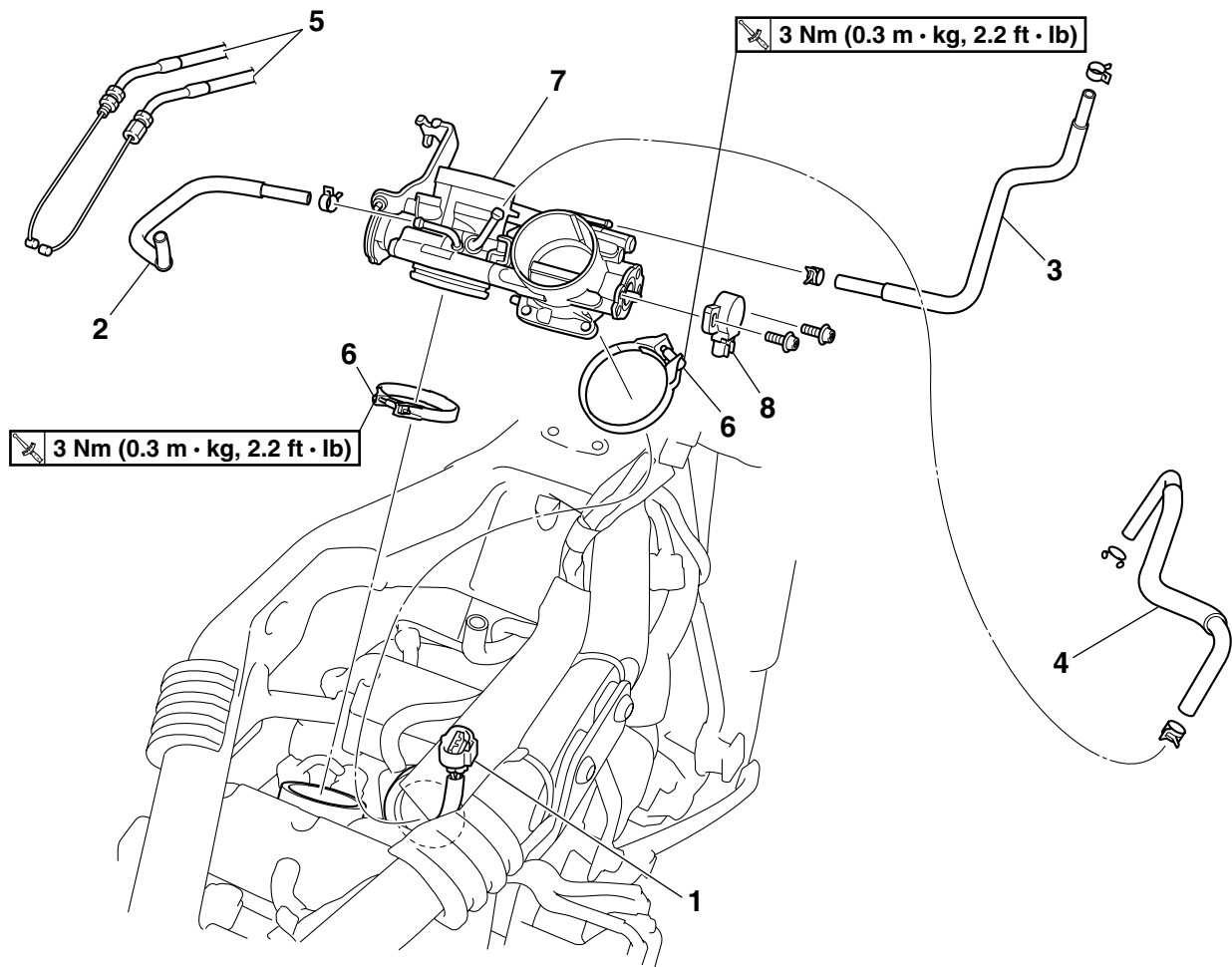

Order	Job/Parts to remove	Q'ty	Remarks
	Rider seat/Rider seat bracket		Refer to "GENERAL CHASSIS" on page 4-1.
	Fuel tank		Refer to "FUEL TANK" on page 6-1.
	Air filter case		Refer to "GENERAL CHASSIS" on page 4-1.
	Cylinder-#1 ignition coil cover		Refer to "ENGINE REMOVAL" on page 5-1.
1	Throttle position sensor coupler	1	Disconnect.
2	Cylinder-#1 intake air pressure sensor hose	1	
3	Cylinder-#2 intake air pressure sensor hose	1	
4	Canister purge hose	1	For California only
5	Throttle cable	2	Disconnect.
6	Throttle body joint clamp screw	2	Loosen.
7	Throttle body	1	<small>EC1D71013</small> CAUTION: _____ The throttle bodies should not be disassembled.
8	Throttle position sensor	1	
			For installation, reverse the removal procedure.

THROTTLE BODIES

Removing the intake manifolds

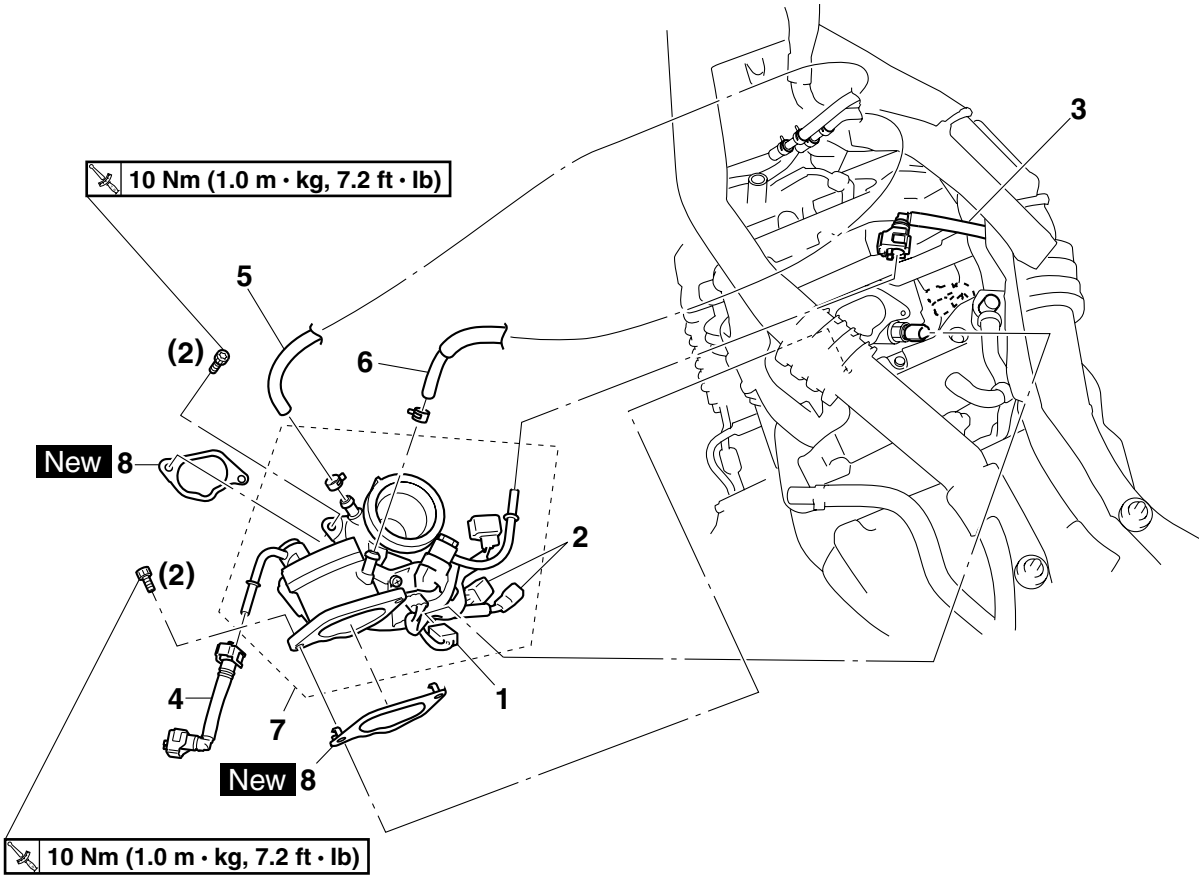

Order	Job/Parts to remove	Q'ty	Remarks
1	Engine temperature sensor coupler	1	Disconnect.
2	Sub-wire harness 2 coupler	2	Disconnect.
3	Fuel outlet hose	1	Disconnect.
4	Fuel hose (intake manifold assembly to pressure regulator)	1	
5	Cylinder-#2 ISC (idle speed control) unit outlet hose	1	Disconnect.
6	Cylinder-#1 ISC (idle speed control) unit outlet hose	1	Disconnect.
7	Intake manifold assembly	1	
8	Gasket	2	
			For installation, reverse the removal procedure.

THROTTLE BODIES

Disassembling the intake manifolds

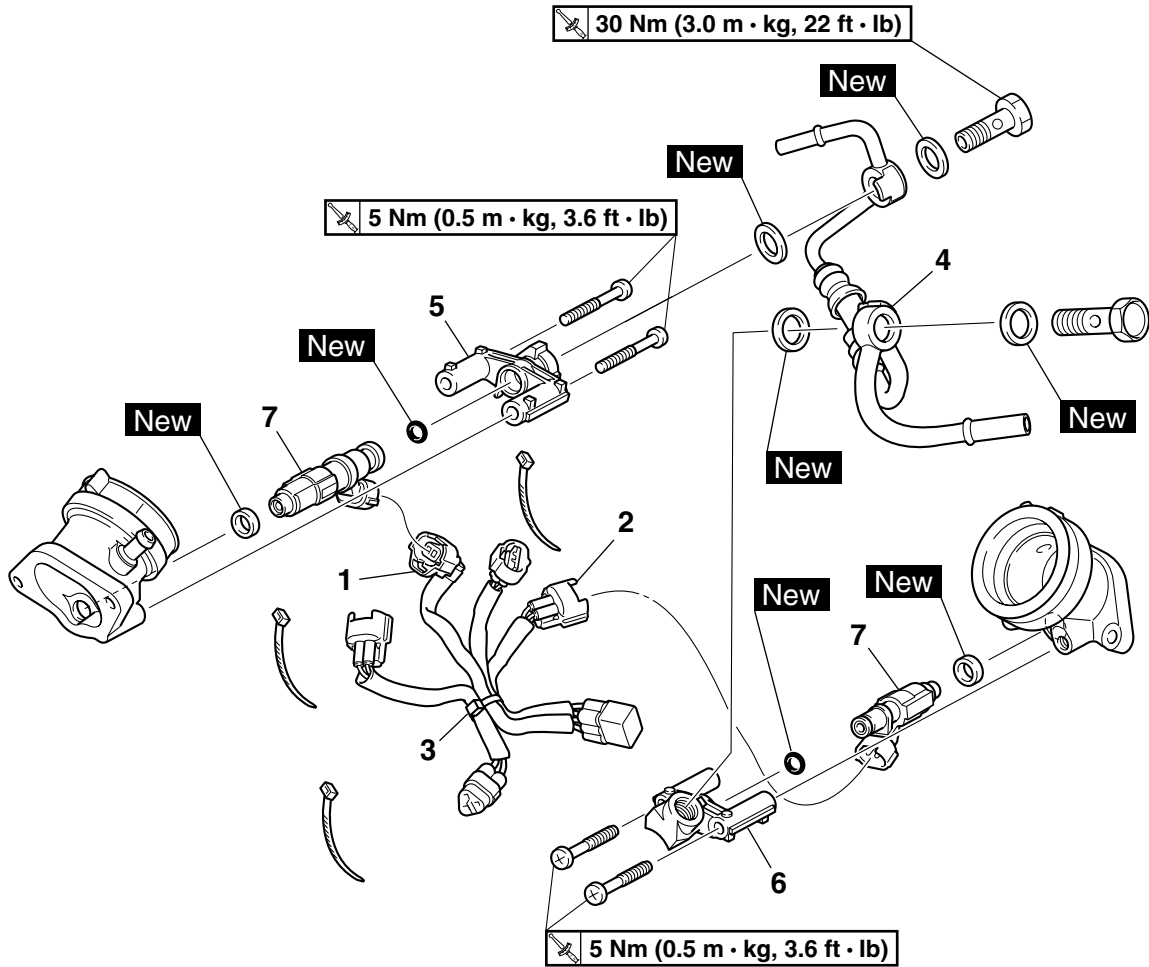

Order	Job/Parts to remove	Q'ty	Remarks
1	Cylinder-#1 injector coupler	1	Disconnect.
2	Cylinder-#2 injector coupler	1	Disconnect.
3	Sub-wire harness 2	1	
4	Fuel pipe	1	
5	Injector joint 1	1	
6	Injector joint 2	1	
7	Injector	2	
			For assembly, reverse the disassembly procedure.



Vacuum/pressure pump gauge set

90890-06756

Mityvac brake bleeding tool

YS-42423

Pressure gauge

90890-03153

YU-03153

Fuel pressure adapter

90890-03176

YM-03176

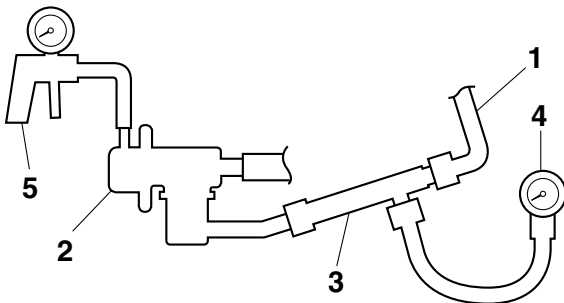
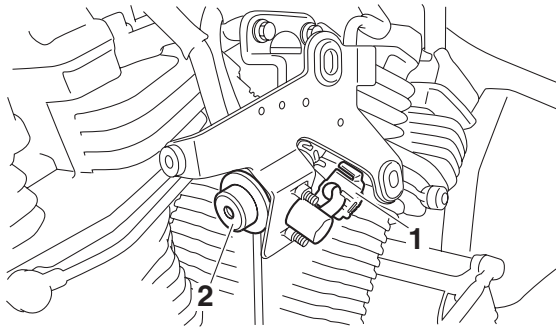

- f. Start the engine.
- g. Measure the fuel pressure.



Fuel pressure

392 kPa (3.92 kg/cm², 55.7 psi)

- h. Use the vacuum/pressure pump gauge set to adjust the fuel pressure in relation to the vacuum pressure as described below.

NOTE:

The vacuum pressure should not exceed 100 kPa (760 mmHg).

- Increase the vacuum pressure → Fuel pressure is decreased
- Decrease the vacuum pressure → Fuel pressure is increased

Faulty → Replace the pressure regulator.

EAS27030

ADJUSTING THE THROTTLE POSITION SENSOR

1. Check:
 - Throttle position sensor
 Refer to "CHECKING THE THROTTLE POSITION SENSOR" on page 7-89.
2. Adjust:
 - Throttle position sensor angle

- a. Connect the throttle position sensor coupler to the throttle position sensor.
- b. Connect the digital circuit tester to the throttle position sensor.

- Positive tester probe yellow terminal "1"
- Negative tester probe black terminal "2"



Digital circuit tester

90890-03174

Model 88 Multimeter with tachometer

YU-A1927

- c. Turn the main switch to "ON".
- d. Measure the throttle position sensor output voltage.
- e. Adjust the throttle position sensor angle so that the output voltage is within the specified range.



Output voltage (at idle)

0.63–0.73 V

- f. After adjusting the throttle position sensor angle, tighten the throttle position sensor screws "3".

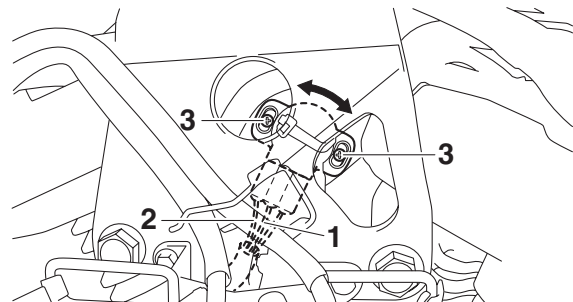

ET1D71008

INSTALLING THE FUEL PIPE

1. Install:
 - Fuel pipe "1"



Fuel pipe bolt
30 Nm (3.0 m·kg, 22 ft·lb)

NOTE: _____
Install the fuel pipe “1” so that it contacts the projections “a” on the injector joints.

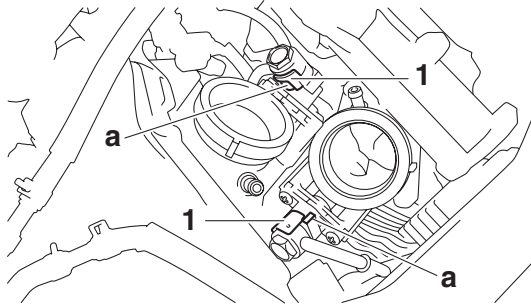

ET1D71027

INSTALLING THE FUEL HOSE

1. Connect:
 - Fuel hose (intake manifold assembly to pressure regulator)

EC1D71015

CAUTION: _____

When installing the fuel hose, make sure that it is securely connected, and that the fuel hose connector cover on the fuel hose is in the correct position, otherwise the fuel hose will not be properly installed.

NOTE: _____

- Install the fuel hose securely onto the fuel pipe or pressure regulator until a distinct “click” is heard.
- To install the fuel hose onto the fuel pipe or pressure regulator, slide the fuel hose connector cover “1” on the end of the hose in the direction of the arrow shown.

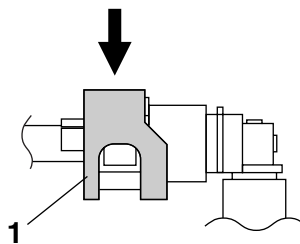

ISC (IDLE SPEED CONTROL) UNIT

ET1D71009

ISC (IDLE SPEED CONTROL) UNIT

Removing the ISC (idle speed control) unit

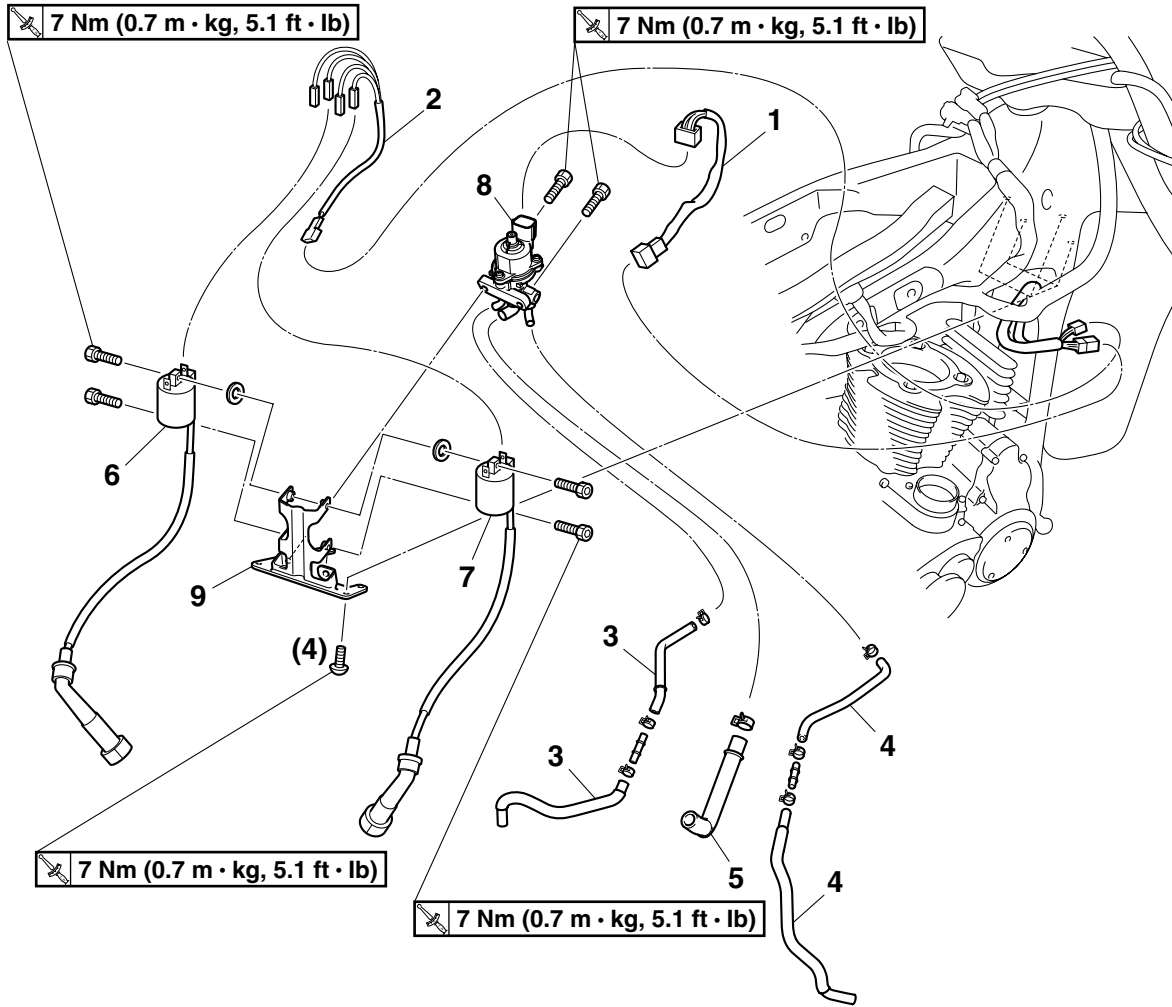

Order	Job/Parts to remove	Q'ty	Remarks
	Front cylinder head		Refer to "CYLINDER HEADS" on page 5-36.
1	Sub-wire harness 4	1	
2	Sub-wire harness 3	1	
3	Cylinder-#2 ISC (idle speed control) unit outlet hose	2	
4	Cylinder-#1 ISC (idle speed control) unit outlet hose	2	
5	ISC (idle speed control) unit inlet hose	1	
6	Cylinder-#2 left ignition coil	1	For XV19S(C)/ XV19M(C)/ XV19CTS(C)/ XV19CTM(C)
7	Cylinder-#2 right ignition coil	1	For XV19S(C)/ XV19M(C)/ XV19CTS(C)/ XV19CTM(C)
8	ISC (idle speed control) unit	1	
9	ISC (idle speed control) unit bracket	1	
			For installation, reverse the removal procedure.

ET1D71010

CHECKING THE ISC (IDLE SPEED CONTROL) SYSTEM

1. Check:

- Hoses

Loose connections → Connect properly.

Cracks/damage → Replace.

ELECTRICAL SYSTEM

IGNITION SYSTEM	7-1
CIRCUIT DIAGRAM	7-1
ENGINE STOPPING DUE TO SIDESTAND OPERATION	7-3
TROUBLESHOOTING	7-4
ELECTRIC STARTING SYSTEM	7-7
CIRCUIT DIAGRAM	7-7
STARTING CIRCUIT CUT-OFF SYSTEM OPERATION	7-9
TROUBLESHOOTING	7-11
CHARGING SYSTEM	7-13
CIRCUIT DIAGRAM	7-13
TROUBLESHOOTING	7-15
LIGHTING SYSTEM	7-17
CIRCUIT DIAGRAM	7-17
TROUBLESHOOTING	7-19
SIGNALING SYSTEM	7-21
CIRCUIT DIAGRAM	7-21
TROUBLESHOOTING	7-23
FUEL INJECTION SYSTEM	7-27
CIRCUIT DIAGRAM	7-27
ECU SELF-DIAGNOSTIC FUNCTION	7-29
SELF-DIAGNOSTIC FUNCTION TABLE	7-30
TROUBLESHOOTING METHOD	7-32
DIAGNOSTIC MODE	7-33
TROUBLESHOOTING DETAILS	7-40
FUEL PUMP SYSTEM	7-63
CIRCUIT DIAGRAM	7-63
TROUBLESHOOTING	7-65

ELECTRICAL COMPONENTS	7-67
CHECKING THE SWITCHES	7-71
CHECKING THE BULBS AND BULB SOCKETS	7-74
CHECKING THE FUSES	7-75
CHECKING AND CHARGING THE BATTERY	7-76
CHECKING THE RELAYS	7-79
CHECKING THE TURN SIGNAL RELAY	7-80
CHECKING THE DIODES.....	7-81
CHECKING THE IGNITION SPARK GAP.....	7-83
CHECKING THE SPARK PLUG CAPS.....	7-83
CHECKING THE IGNITION COILS.....	7-84
CHECKING THE CRANKSHAFT POSITION SENSOR.....	7-84
CHECKING THE LEAN ANGLE SENSOR.....	7-85
CHECKING THE STARTER MOTOR OPERATION	7-85
CHECKING THE STATOR COIL	7-85
CHECKING THE RECTIFIER/REGULATOR	7-86
CHECKING THE HORNS	7-86
CHECKING THE ENGINE TEMPERATURE SENSOR	7-87
CHECKING THE FUEL SENDER (FUEL TANK)	7-88
CHECKING THE FUEL SENDER (FUEL PUMP)	7-88
CHECKING THE FUEL LEVEL WARNING LIGHT	7-89
CHECKING THE SPEED SENSOR	7-89
CHECKING THE THROTTLE POSITION SENSOR	7-89
CHECKING THE FUEL PUMP.....	7-90
CHECKING THE EXUP SERVO MOTOR.....	7-90
CHECKING THE INTAKE AIR PRESSURE SENSOR	7-91
CHECKING THE AIR TEMPERATURE SENSOR	7-91



EAS27090

IGNITION SYSTEM

EAS27110

CIRCUIT DIAGRAM

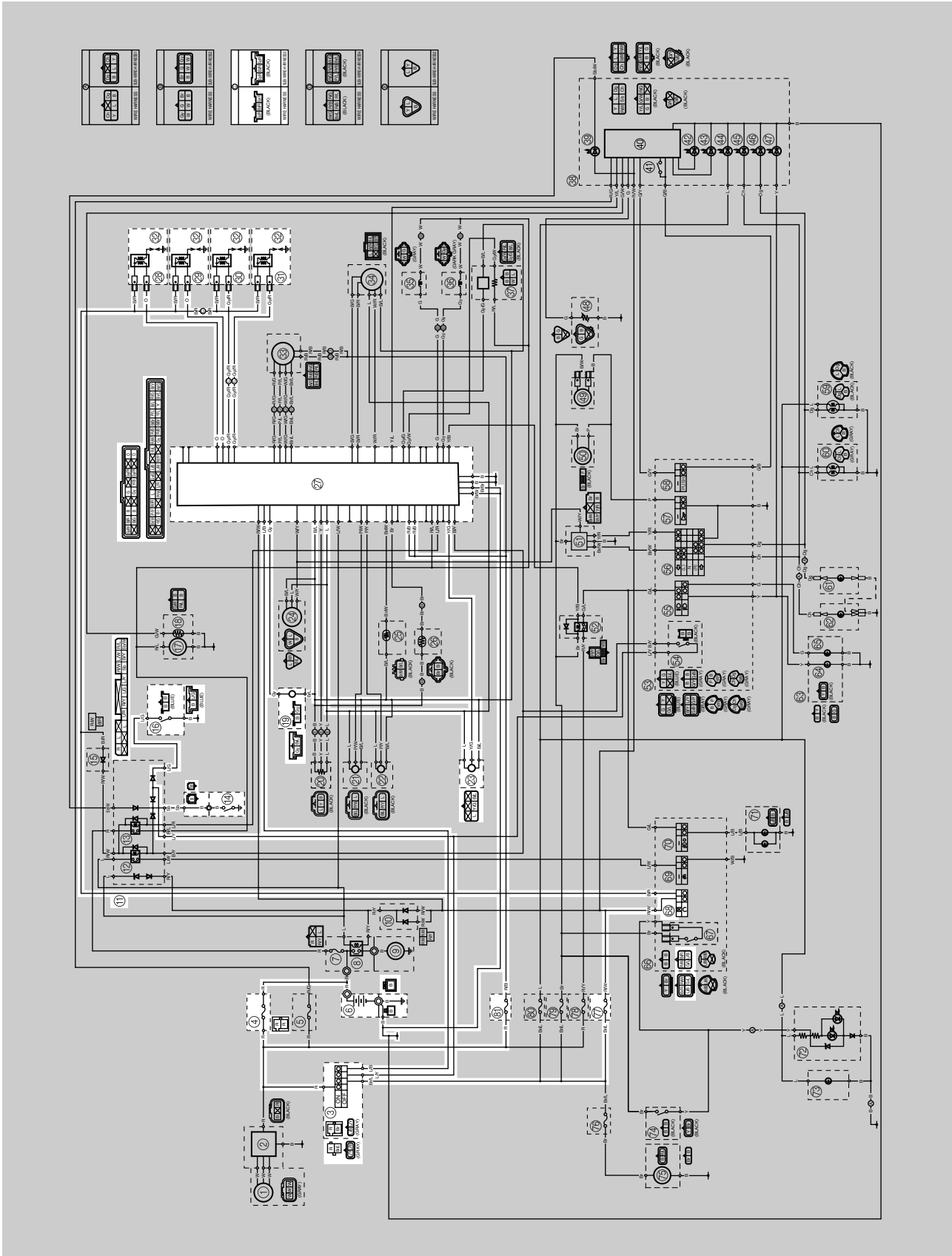

- 3. Main switch
- 4. Main fuse
- 6. Battery
- 11. Relay unit
- 14. Neutral switch
- 16. Sidestand switch
- 19. Crankshaft position sensor
- 23. Lean angle sensor
- 27. ECU (electronic control unit)
- 28. Cylinder-#1 left ignition coil
- 29. Cylinder-#1 right ignition coil
- 30. Cylinder-#2 left ignition coil
- 31. Cylinder-#2 right ignition coil
- 32. Spark plug
- 68. Engine stop switch
- 77. Ignition fuse
- 81. ECU fuse (for XV19S(C)/ XV19M(C)/
XV19CTS(C)/ XV19CTM(C))

ET1D71043

ENGINE STOPPING DUE TO SIDESTAND OPERATION

When the engine is running and the transmission is in gear, the engine will stop if the sidestand is moved down. This is because the electric current from the ignition coils does not flow to the ECU when both the neutral switch and sidestand switch are set to "OFF", thereby preventing the spark plugs from producing a spark. However, the engine continues to run under the following conditions:

- The transmission is in gear (the neutral switch circuit is open) and the sidestand is up (the sidestand switch circuit is closed).
- The transmission is in neutral (the neutral switch circuit is closed) and the sidestand is down (the sidestand switch circuit is open).

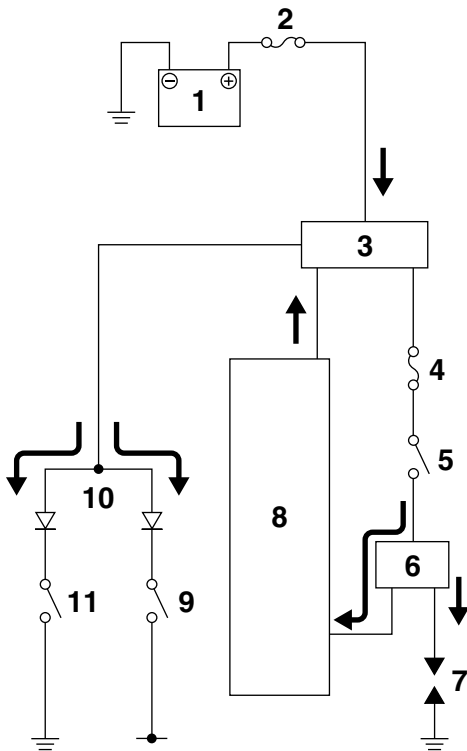

1. Battery
2. Main fuse
3. Main switch
4. Ignition fuse
5. Engine stop switch
6. Ignition coil
7. Spark plug
8. ECU (electronic control unit)
9. Sidestand switch
10. Relay unit (diode)
11. Neutral switch

EAS27140

TROUBLESHOOTING

The ignition system fails to operate (no spark or intermittent spark).

NOTE:

• Before troubleshooting, remove the following part(s):

1. Rider seat
2. Tool kit tray
3. Rider seat bracket assembly
4. Fuel tank
5. Air filter case
6. Headlight assembly
7. Exhaust pipes
8. Front cylinder

<p>1. Check the fuses. (Main, ignition and ECU (for XV19S(C)/ XV19M(C)/ XV19CTS(C)/ XV19CTM(C))) Refer to "CHECKING THE FUSES" on page 7-75.</p>	<p>NG →</p>	<p>Replace the fuse(s).</p>
<p>OK ↓</p>		
<p>2. Check the battery. Refer to "CHECKING AND CHARGING THE BATTERY" on page 7-76.</p>	<p>NG →</p>	<ul style="list-style-type: none"> • Clean the battery terminals. • Recharge or replace the battery.
<p>OK ↓</p>		
<p>3. Check the spark plugs. Refer to "CHECKING THE SPARK PLUGS" on page 3-9.</p>	<p>NG →</p>	<p>Re-gap or replace the spark plug(s).</p>
<p>OK ↓</p>		
<p>4. Check the ignition spark gap. Refer to "CHECKING THE IGNITION SPARK GAP" on page 7-83.</p>	<p>OK →</p>	<p>Ignition system is OK.</p>
<p>NG ↓</p>		
<p>5. Check the spark plug caps. Refer to "CHECKING THE SPARK PLUG CAPS" on page 7-83.</p>	<p>NG →</p>	<p>Replace the spark plug cap(s).</p>
<p>OK ↓</p>		
<p>6. Check the ignition coils. Refer to "CHECKING THE IGNITION COILS" on page 7-84.</p>	<p>NG →</p>	<p>Replace the ignition coil(s).</p>
<p>OK ↓</p>		

IGNITION SYSTEM

7. Check the crankshaft position sensor. Refer to "CHECKING THE CRANKSHAFT POSITION SENSOR" on page 7-84.	NG →	Replace the crankshaft position sensor.
OK ↓		
8. Check the main switch. Refer to "CHECKING THE SWITCHES" on page 7-71.	NG →	Replace the main switch.
OK ↓		
9. Check the engine stop switch. Refer to "CHECKING THE SWITCHES" on page 7-71.	NG →	The engine stop switch is faulty. Replace the right handlebar switch.
OK ↓		
10. Check the neutral switch. Refer to "CHECKING THE SWITCHES" on page 7-71.	NG →	Replace the neutral switch.
OK ↓		
11. Check the sidestand switch. Refer to "CHECKING THE SWITCHES" on page 7-71.	NG →	Replace the sidestand switch.
OK ↓		
12. Check the relay unit (diode). Refer to "CHECKING THE DIODES" on page 7-81.	NG →	Replace the relay unit.
OK ↓		
13. Check the lean angle sensor. Refer to "CHECKING THE LEAN ANGLE SENSOR" on page 7-85.	NG →	Replace the lean angle sensor.
OK ↓		
14. Check the entire ignition system wiring. Refer to "CIRCUIT DIAGRAM" on page 7-1.	NG →	Properly connect or repair the ignition system wiring.
OK ↓		
Replace the ECU.		

EAS27160

ELECTRIC STARTING SYSTEM

EAS27170

CIRCUIT DIAGRAM

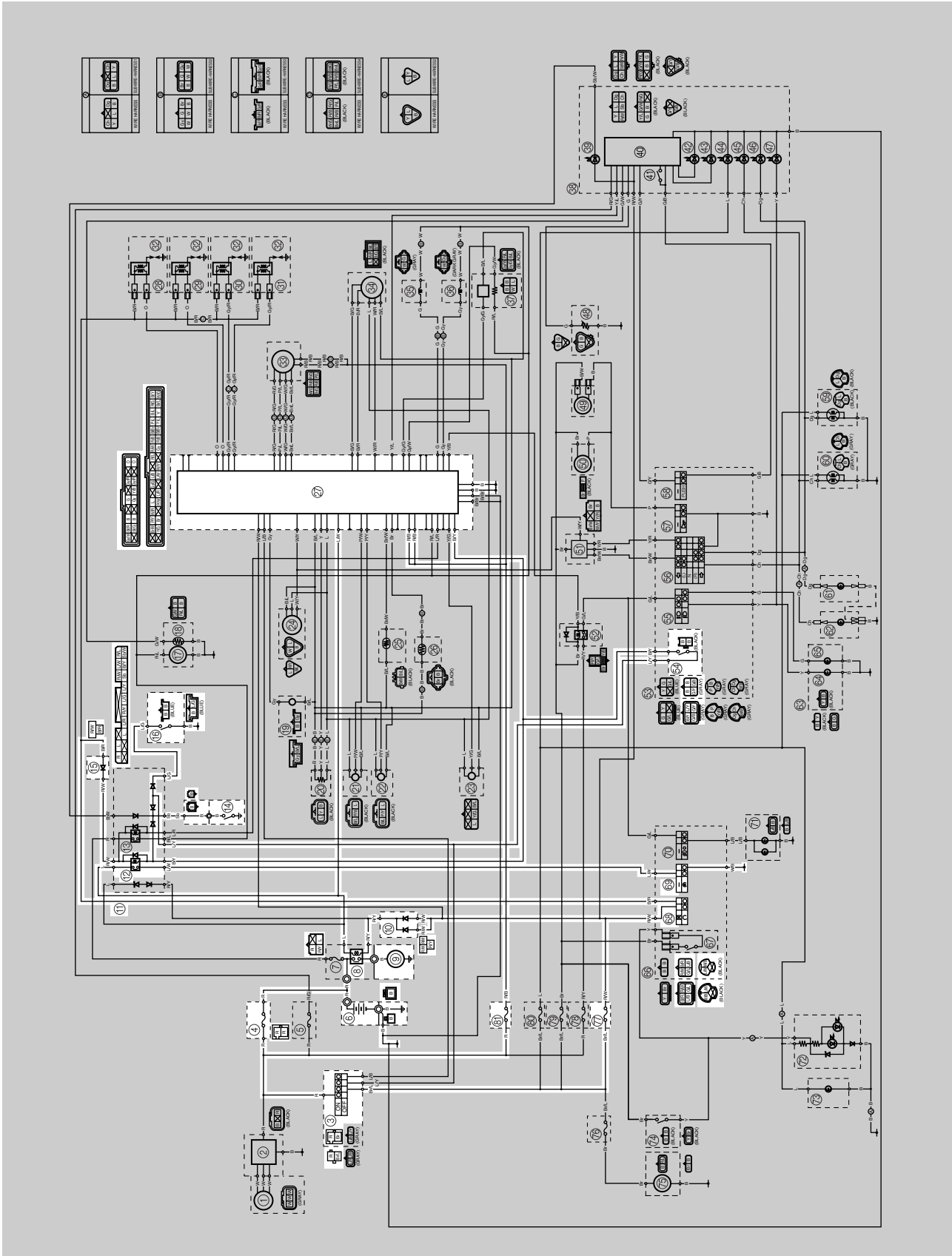

- 3. Main switch
- 4. Main fuse
- 6. Battery
- 8. Starter relay
- 9. Starter motor
- 10. Diode 1 (for XV19S(C)/ XV19M(C)/
XV19CTS(C)/ XV19CTM(C))
- 11. Relay unit
- 12. Starting circuit cut-off relay
- 14. Neutral switch
- 15. Diode 2 (for XV19S(C)/ XV19M(C)/
XV19CTS(C)/ XV19CTM(C))
- 16. Sidestand switch
- 27. ECU (electronic control unit)
- 54. Clutch switch
- 68. Engine stop switch
- 69. Start switch
- 77. Ignition fuse
- 81. ECU fuse (for XV19S(C)/ XV19M(C)/
XV19CTS(C)/ XV19CTM(C))

EAS27180

STARTING CIRCUIT CUT-OFF SYSTEM OPERATION

If the engine stop switch is set to “○” and the main switch is turned “ON” (both switch circuits are closed), the starter motor can only operate if at least one of the following conditions is met:

- The transmission is in neutral (the neutral switch circuit is closed).
- The clutch lever is pulled to the handlebar (the clutch switch circuit is closed) and the sidestand is up (the sidestand switch circuit is closed).

The starting circuit cut-off relay prevents the starter motor from operating when neither of these conditions has been met. In this instance, the starting circuit cut-off relay stays open so current cannot reach the starter motor. When at least one of the above conditions has been met, the starting circuit cut-off relay is closed and the engine can be started by pushing the start switch “⊕”.

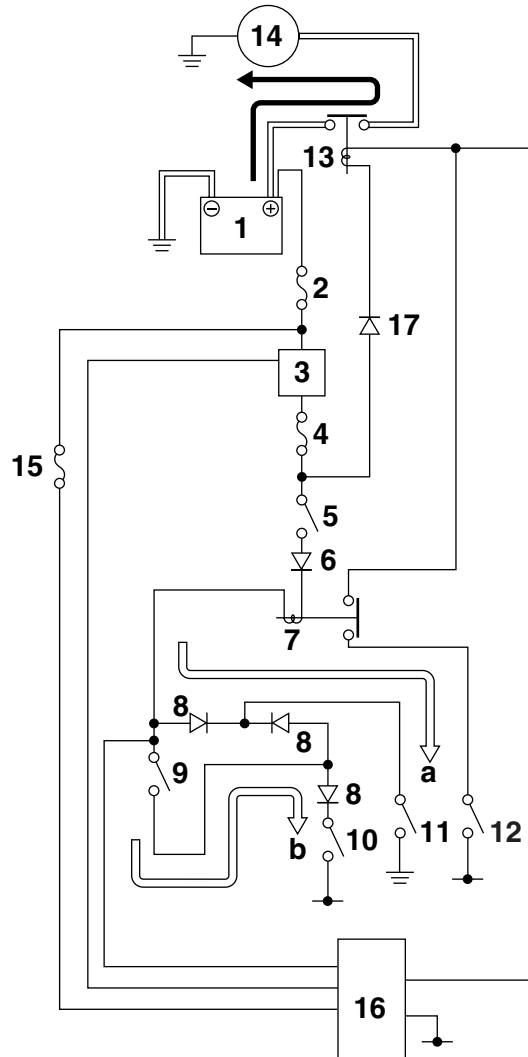

- a. WHEN THE TRANSMISSION IS IN NEUTRAL
- b. WHEN THE SIDESTAND IS UP AND THE CLUTCH LEVER IS PULLED TO THE HANDLEBAR
 1. Battery
 2. Main fuse
 3. Main switch
 4. Ignition fuse
 5. Engine stop switch
 6. Diode 2 (for XV19S(C)/ XV19M(C)/ XV19CTS(C)/ XV19CTM(C))
 7. Relay unit (starting circuit cut-off relay)
 8. Relay unit (diode)
 9. Clutch switch
 10. Sidestand switch
 11. Neutral switch
 12. Start switch
 13. Starter relay
 14. Starter motor
 15. ECU fuse (for XV19S(C)/ XV19M(C)/ XV19CTS(C)/ XV19CTM(C))
 16. ECU (electronic control unit)
 17. Diode 1 (for XV19S(C)/ XV19M(C)/ XV19CTS(C)/ XV19CTM(C))

EAS27190

TROUBLESHOOTING

The starter motor fails to turn.

NOTE:

• Before troubleshooting, remove the following part(s):

1. Rider seat
2. Tool kit tray
3. Headlight assembly

<p>1. Check the fuses. (Main, ignition and ECU (for XV19S(C)/ XV19M(C)/ XV19CTS(C)/ XV19CTM(C))) Refer to "CHECKING THE FUSES" on page 7-75.</p>	<p>NG →</p>	<p>Replace the fuse(s).</p>
<p>OK ↓</p>		
<p>2. Check the battery. Refer to "CHECKING AND CHARGING THE BATTERY" on page 7-76.</p>	<p>NG →</p>	<ul style="list-style-type: none"> • Clean the battery terminals. • Recharge or replace the battery.
<p>OK ↓</p>		
<p>3. Check the starter motor operation. Refer to "CHECKING THE STARTER MOTOR OPERATION" on page 7-85.</p>	<p>OK →</p>	<p>Starter motor is OK. Perform the electric starting system troubleshooting, starting with step 5.</p>
<p>NG ↓</p>		
<p>4. Check the starter motor. Refer to "CHECKING THE STARTER MOTOR" on page 5-84.</p>	<p>NG →</p>	<p>Repair or replace the starter motor.</p>
<p>OK ↓</p>		
<p>5. Check the relay unit (starting circuit cut-off relay). Refer to "CHECKING THE RELAYS" on page 7-79.</p>	<p>NG →</p>	<p>Replace the relay unit.</p>
<p>OK ↓</p>		
<p>6. Check the relay unit (diode). Refer to "CHECKING THE DIODES" on page 7-81.</p>	<p>NG →</p>	<p>Replace the relay unit.</p>
<p>OK ↓</p>		
<p>7. Check the diode 1. (for XV19S(C)/ XV19M(C)/ XV19CTS(C)/ XV19CTM(C)) Refer to "CHECKING THE DIODES" on page 7-81.</p>	<p>NG →</p>	<p>Replace the diode 1.</p>
<p>OK ↓</p>		

ELECTRIC STARTING SYSTEM

8. Check the diode 2. (for XV19S(C)/ XV19M(C)/ XV19CTS(C)/ XV19CTM(C)) Refer to "CHECKING THE DI- ODES" on page 7-81.	NG →	Replace the diode 2.
OK ↓		
9. Check the starter relay. Refer to "CHECKING THE RE- LAYES" on page 7-79.	NG →	Replace the starter relay.
OK ↓		
10. Check the main switch. Refer to "CHECKING THE SWITCHES" on page 7-71.	NG →	Replace the main switch.
OK ↓		
11. Check the engine stop switch. Refer to "CHECKING THE SWITCHES" on page 7-71.	NG →	The engine stop switch is faulty. Replace the right handlebar switch.
OK ↓		
12. Check the neutral switch. Refer to "CHECKING THE SWITCHES" on page 7-71.	NG →	Replace the neutral switch.
OK ↓		
13. Check the sidestand switch. Refer to "CHECKING THE SWITCHES" on page 7-71.	NG →	Replace the sidestand switch.
OK ↓		
14. Check the clutch switch. Refer to "CHECKING THE SWITCHES" on page 7-71.	NG →	Replace the clutch switch.
OK ↓		
15. Check the start switch. Refer to "CHECKING THE SWITCHES" on page 7-71.	NG →	The start switch is faulty. Replace the right handlebar switch.
OK ↓		
16. Check the entire starting system wiring. Refer to "CIRCUIT DIAGRAM" on page 7-7.	NG →	Properly connect or repair the starting sys- tem wiring.
OK ↓		
The starting system circuit is OK.		

EAS27200

CHARGING SYSTEM

EAS27210

CIRCUIT DIAGRAM

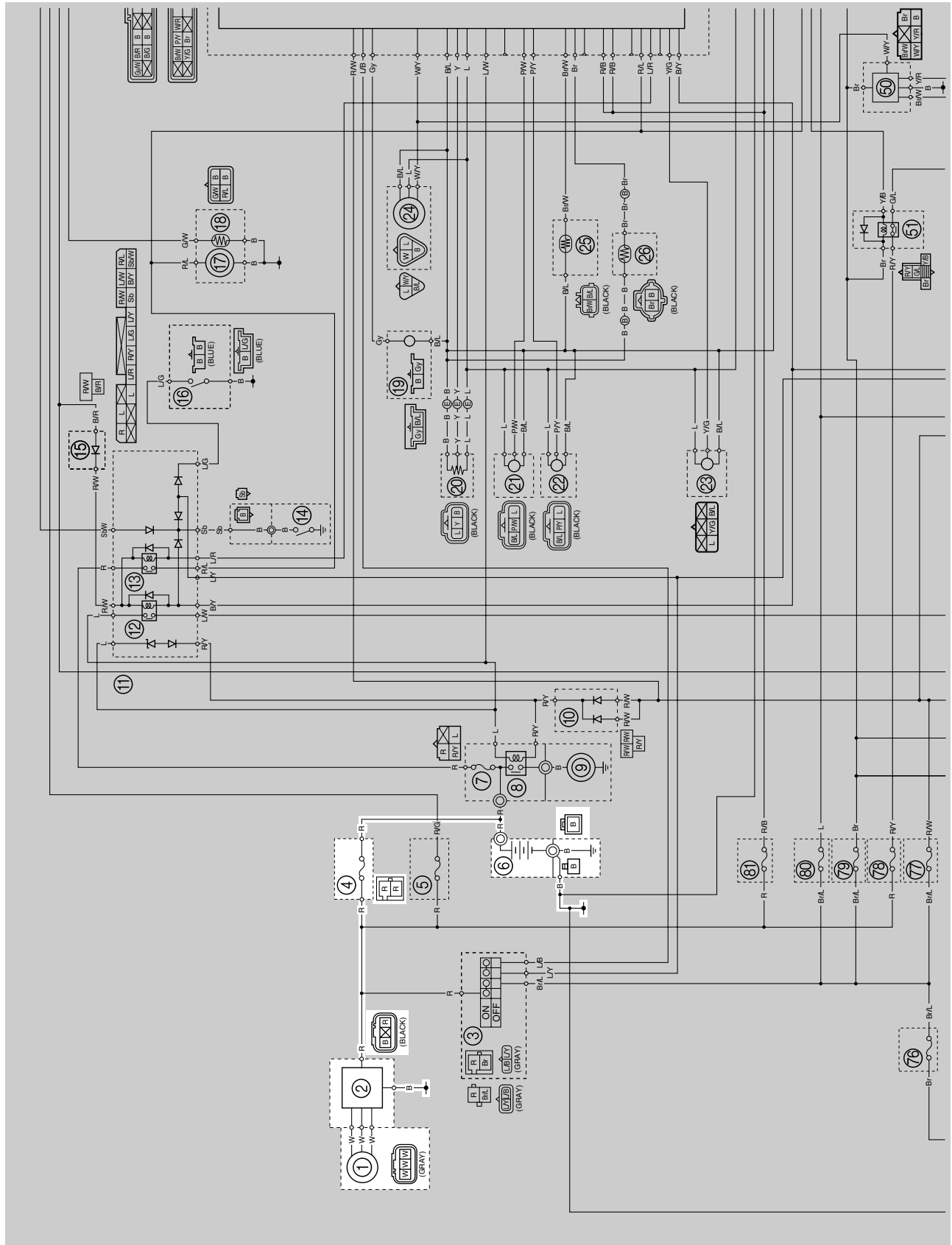

1. AC magneto
2. Rectifier/regulator
4. Main fuse
6. Battery

EAS27220

TROUBLESHOOTING

The battery is not being charged.

NOTE:

• Before troubleshooting, remove the following part(s):

1. Rider seat
2. Rectifier/regulator cover
3. Lead cover

<p>1. Check the fuse. (Main) Refer to "CHECKING THE FUSES" on page 7-75.</p>	<p>NG →</p>	<p>Replace the fuse.</p>
<p>OK ↓</p>		
<p>2. Check the battery. Refer to "CHECKING AND CHARGING THE BATTERY" on page 7-76.</p>	<p>NG →</p>	<ul style="list-style-type: none"> • Clean the battery terminals. • Recharge or replace the battery.
<p>OK ↓</p>		
<p>3. Check the stator coil. Refer to "CHECKING THE STATOR COIL" on page 7-85.</p>	<p>NG →</p>	<p>Replace the stator coil.</p>
<p>OK ↓</p>		
<p>4. Check the rectifier/regulator. Refer to "CHECKING THE RECTIFIER/REGULATOR" on page 7-86.</p>	<p>NG →</p>	<p>Replace the rectifier/regulator.</p>
<p>OK ↓</p>		
<p>5. Check the entire charging system wiring. Refer to "CIRCUIT DIAGRAM" on page 7-13.</p>	<p>NG →</p>	<p>Properly connect or repair the charging system wiring.</p>
<p>OK ↓</p>		
<p>The charging system circuit is OK.</p>		

- 3. Main switch
- 4. Main fuse
- 6. Battery
- 27. ECU (electronic control unit)
- 44. Meter light
- 47. High beam indicator light
- 52. Headlight relay
- 55. Dimmer switch
- 59. Front right turn signal/position light
- 60. Front left turn signal/position light
- 64. Headlight (high beam)
- 65. Headlight (low beam)
- 70. Accessory light switch
- 71. Accessory light (OPTION)
- 72. Tail/brake light
- 73. License plate light
- 78. Headlight fuse
- 79. Signaling system fuse
- 80. Taillight fuse
- 81. ECU fuse (for XV19S(C)/ XV19M(C)/
XV19CTS(C)/ XV19CTM(C))

EAS27260

TROUBLESHOOTING

Any of the following fail to light: headlight (high beam), headlight (low beam), high beam indicator light, taillight, license light, position light, meter light or accessory light (OPTION).

NOTE:

• Before troubleshooting, remove the following part(s):

1. Rider seat
2. Tool kit tray
3. Headlight assembly

<p>1. Check the condition of each bulb and bulb socket. Refer to "CHECKING THE BULBS AND BULB SOCKETS" on page 7-74.</p>	<p>NG →</p>	<p>Replace the bulb(s) and bulb socket(s).</p>
<p>OK ↓</p>		
<p>2. Check the fuses. (Main, headlight, signaling system, taillight and ECU (for XV19S(C)/XV19M(C)/XV19CTS(C)/XV19CTM(C))) Refer to "CHECKING THE FUSES" on page 7-75.</p>	<p>NG →</p>	<p>Replace the fuse(s).</p>
<p>OK ↓</p>		
<p>3. Check the battery. Refer to "CHECKING AND CHARGING THE BATTERY" on page 7-76.</p>	<p>NG →</p>	<ul style="list-style-type: none"> • Clean the battery terminals. • Recharge or replace the battery.
<p>OK ↓</p>		
<p>4. Check the main switch. Refer to "CHECKING THE SWITCHES" on page 7-71.</p>	<p>NG →</p>	<p>Replace the main switch.</p>
<p>OK ↓</p>		
<p>5. Check the dimmer switch. Refer to "CHECKING THE SWITCHES" on page 7-71.</p>	<p>NG →</p>	<p>The dimmer switch is faulty. Replace the left handlebar switch.</p>
<p>OK ↓</p>		
<p>6. Check the accessory light switch. Refer to "CHECKING THE SWITCHES" on page 7-71.</p>	<p>NG →</p>	<p>The accessory light switch is faulty. Replace the right handlebar switch.</p>
<p>OK ↓</p>		
<p>7. Check the headlight relay. Refer to "CHECKING THE RELAYS" on page 7-79.</p>	<p>NG →</p>	<p>Replace the headlight relay.</p>
<p>OK ↓</p>		

8. Check the entire lighting system wiring.
Refer to "CIRCUIT DIAGRAM" on page 7-17.

OK ↓

The lighting system circuit is OK.

NG →

Properly connect or repair the lighting system wiring.

3. Main switch
4. Main fuse
5. Backup fuse (odometer and clock)
6. Battery
11. Relay unit
14. Neutral switch
18. Fuel sender (fuel pump)
24. Speed sensor
27. ECU (electronic control unit)
39. Neutral indicator light
40. Multi-function meter
43. Fuel level warning light
45. Left turn signal indicator light
46. Right turn signal indicator light
48. Fuel sender (fuel tank)
49. Horn 1
50. Horn 2
51. Turn signal relay
56. Turn signal switch
57. Horn switch
59. Front right turn signal/position light
60. Front left turn signal/position light
61. Rear right turn signal light
62. Rear left turn signal light
67. Front brake light switch
72. Tail/brake light
74. Rear brake light switch
77. Ignition fuse
79. Signaling system fuse
81. ECU fuse (for XV19S(C)/ XV19M(C)/
XV19CTS(C)/ XV19CTM(C))

EAS27290

TROUBLESHOOTING

- Any of the following fail to light: turn signal light, brake light or an indicator light.
- The horn fails to sound.
- The fuel level gauge fails to operate.
- The speedometer fails to operate.

NOTE:

- Before troubleshooting, remove the following part(s):
 1. Rider seat
 2. Tool kit tray
 3. Rider seat bracket assembly
 4. Headlight assembly
 5. Fuel tank

<p>1. Check the fuses. (Main, backup, ignition, signaling system and ECU (for XV19S(C)/XV19M(C)/XV19CTS(C)/XV19CTM(C))) Refer to "CHECKING THE FUSES" on page 7-75.</p>	<p>NG →</p>	<p>Replace the fuse(s).</p>
OK ↓		
<p>2. Check the battery. Refer to "CHECKING AND CHARGING THE BATTERY" on page 7-76.</p>	<p>NG →</p>	<ul style="list-style-type: none"> • Clean the battery terminals. • Recharge or replace the battery.
OK ↓		
<p>3. Check the main switch. Refer to "CHECKING THE SWITCHES" on page 7-71.</p>	<p>NG →</p>	<p>Replace the main switch.</p>
OK ↓		
<p>4. Check the entire signaling system wiring. Refer to "CIRCUIT DIAGRAM" on page 7-21.</p>	<p>NG →</p>	<p>Properly connect or repair the signaling system wiring.</p>
OK ↓		
<p>Check the condition of each of the signaling system's circuits. Refer to "Checking the signaling system".</p>		

Checking the signaling system

The horn fails to sound.

<p>1. Check the horn switch. Refer to "CHECKING THE SWITCHES" on page 7-71.</p>	<p>NG →</p>	<p>The horn switch is faulty. Replace the left handlebar switch.</p>
OK ↓		

SIGNALING SYSTEM

2. Check the horns. Refer to "CHECKING THE HORNS" on page 7-86.	NG →	Replace the horn(s).
OK ↓		
3. Check the entire signaling system wiring. Refer to "CIRCUIT DIAGRAM" on page 7-21.	NG →	Properly connect or repair the signaling system wiring.
OK ↓		
This circuit is OK.		
<u>The tail/brake light fails to come on.</u>		
1. Check the front brake light switch. Refer to "CHECKING THE SWITCHES" on page 7-71.	NG →	Replace the front brake light switch.
OK ↓		
2. Check the rear brake light switch. Refer to "CHECKING THE SWITCHES" on page 7-71.	NG →	Replace the rear brake light switch.
OK ↓		
3. Check the entire signaling system wiring. Refer to "CIRCUIT DIAGRAM" on page 7-21.	NG →	Properly connect or repair the signaling system wiring.
OK ↓		
This circuit is OK.		
<u>The turn signal light, turn signal indicator light or both fail to blink.</u>		
1. Check the condition of each bulb and bulb socket. Refer to "CHECKING THE BULBS AND BULB SOCKETS" on page 7-74.	NG →	Replace the bulb(s) and bulb socket(s).
OK ↓		
2. Check the turn signal switch. Refer to "CHECKING THE SWITCHES" on page 7-71.	NG →	The turn signal switch is faulty. Replace the left handlebar switch.
OK ↓		
3. Check the turn signal relay. Refer to "CHECKING THE TURN SIGNAL RELAY" on page 7-80.	NG →	Replace the turn signal relay.
OK ↓		

<p>4. Check the entire signaling system wiring. Refer to "CIRCUIT DIAGRAM" on page 7-21.</p>	<p>NG →</p>	<p>Properly connect or repair the signaling system wiring.</p>
<p>OK ↓</p>		
<p>This circuit is OK.</p>		
<p><u>The neutral indicator light fails to come on.</u></p>		
<p>1. Check the neutral switch. Refer to "CHECKING THE SWITCHES" on page 7-71.</p>	<p>NG →</p>	<p>Replace the neutral switch.</p>
<p>OK ↓</p>		
<p>2. Check the relay unit (diode). Refer to "CHECKING THE DIODES" on page 7-81.</p>	<p>NG →</p>	<p>Replace the relay unit.</p>
<p>OK ↓</p>		
<p>3. Check the entire signaling system wiring. Refer to "CIRCUIT DIAGRAM" on page 7-21.</p>	<p>NG →</p>	<p>Properly connect or repair the signaling system wiring.</p>
<p>OK ↓</p>		
<p>This circuit is OK.</p>		
<p><u>The fuel level gauge fails to operate.</u></p>		
<p>1. Check the fuel sender (fuel tank). Refer to "CHECKING THE FUEL SENDER (FUEL TANK)" on page 7-88.</p>	<p>NG →</p>	<p>Replace the fuel sender.</p>
<p>OK ↓</p>		
<p>2. Check the entire signaling system wiring. Refer to "CIRCUIT DIAGRAM" on page 7-21.</p>	<p>NG →</p>	<p>Properly connect or repair the signaling system wiring.</p>
<p>OK ↓</p>		
<p>Replace the meter assembly.</p>		
<p><u>The fuel level warning light fails to come on.</u></p>		
<p>1. Check the fuel level warning light. Refer to "CHECKING THE FUEL LEVEL WARNING LIGHT" on page 7-89.</p>	<p>NG →</p>	<p>Replace the meter assembly or fuel pump assembly.</p>
<p>OK ↓</p>		

SIGNALING SYSTEM

2. Check the fuel sender (fuel pump). Refer to "CHECKING THE FUEL SENDER (FUEL PUMP)" on page 7-88.

NG →

Replace the fuel pump assembly.

OK ↓

3. Check the entire signaling system wiring. Refer to "CIRCUIT DIAGRAM" on page 7-21.

NG →

Properly connect or repair the signaling system wiring.

OK ↓

This circuit is OK.

The speedometer fails to operate.

1. Check the speed sensor. Refer to "CHECKING THE SPEED SENSOR" on page 7-89.

NG →

Replace the speed sensor.

OK ↓

2. Check the entire signaling system wiring. Refer to "CIRCUIT DIAGRAM" on page 7-21.

NG →

Properly connect or repair the signaling system wiring.

OK ↓

Replace the meter assembly.

EAS27330

FUEL INJECTION SYSTEM

EAS27340

CIRCUIT DIAGRAM

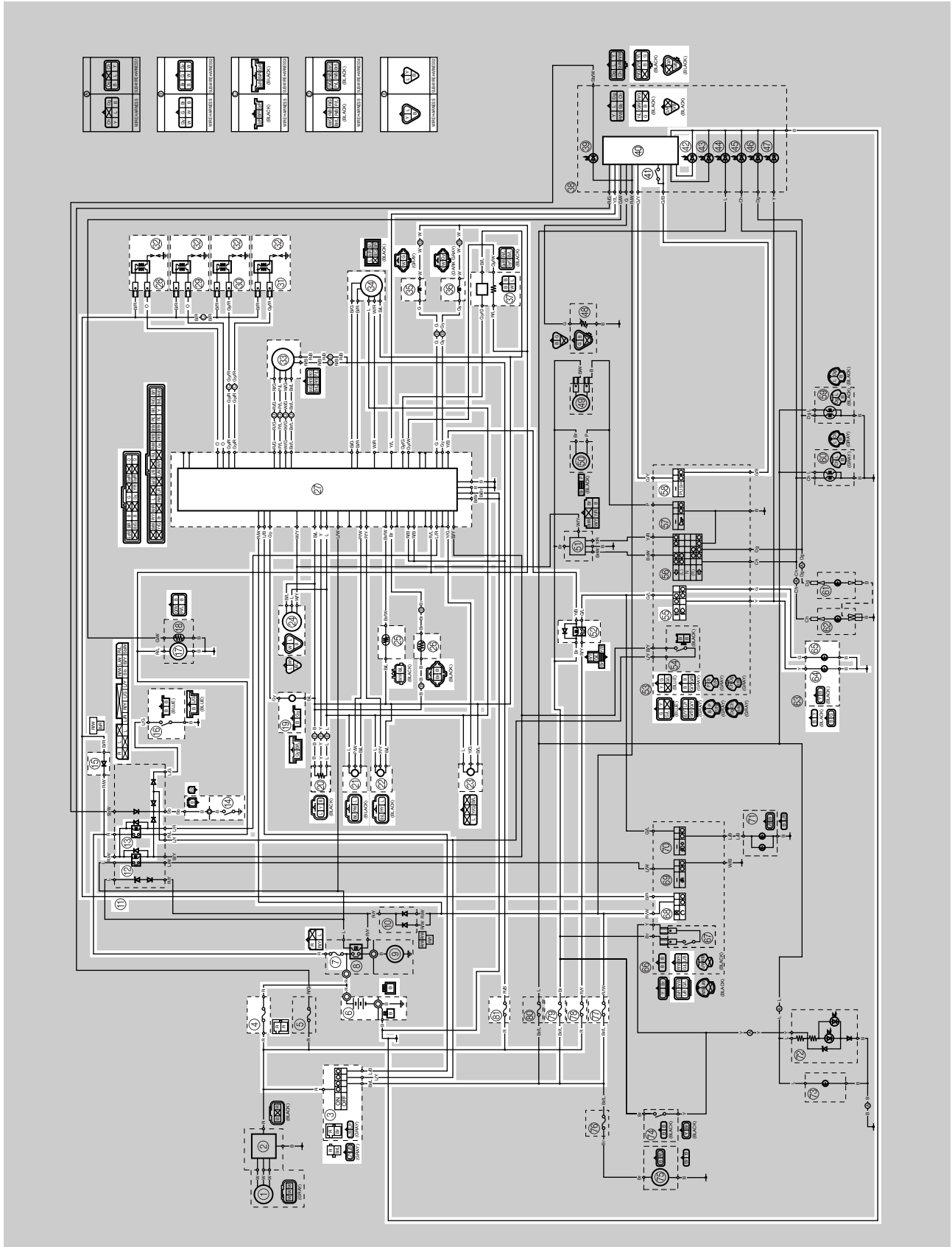

3. Main switch
4. Main fuse
6. Battery
7. Fuel injection system fuse
11. Relay unit
12. Starting circuit cut-off relay
13. Fuel pump relay
14. Neutral switch
15. Diode 2 (for XV19S(C)/ XV19M(C)/
XV19CTS(C)/ XV19CTM(C))
16. Sidestand switch
17. Fuel pump
19. Crankshaft position sensor
20. Throttle position sensor
21. Cylinder-#1 intake air pressure sensor
22. Cylinder-#2 intake air pressure sensor
23. Lean angle sensor
24. Speed sensor
25. Air temperature sensor
26. Engine temperature sensor
27. ECU (electronic control unit)
28. Cylinder-#1 left ignition coil
29. Cylinder-#1 right ignition coil
30. Cylinder-#2 left ignition coil
31. Cylinder-#2 right ignition coil
32. Spark plug
33. ISC (idle speed control) unit
34. EXUP servo motor
35. Injector #2
36. Injector #1
37. O₂ sensor
40. Multi-function meter
41. Reset switch
42. Engine trouble warning light
52. Headlight relay
55. Dimmer switch
58. Select switch
64. Headlight (high beam)
65. Headlight (low beam)
68. Engine stop switch
77. Ignition fuse
78. Headlight fuse
79. Signaling system fuse
81. ECU fuse (for XV19S(C)/ XV19M(C)/
XV19CTS(C)/ XV19CTM(C))

EAS27350

ECU SELF-DIAGNOSTIC FUNCTION

The ECU is equipped with a self-diagnostic function in order to ensure that the fuel injection system is operating normally. If this function detects a malfunction in the system, it immediately operates the engine under substitute characteristics and illuminates the engine trouble warning light to alert the rider that a malfunction has occurred in the system. Once a malfunction has been detected, a fault code is stored in the memory of the ECU.

- To inform the rider that the fuel injection system is not functioning, the engine trouble warning light flashes when the start switch is being pushed to start the engine.
- If a malfunction is detected in the system by the self-diagnostic function, the ECU provides an appropriate substitute characteristic operation, and alerts the rider of the detected malfunction by illuminating the engine trouble warning light.
- After the engine has been stopped, the lowest fault code number appears on the odometer/tripmeter/fuel reserve tripmeter/clock LCD. Once a fault code has been displayed, it remains stored in the memory of the ECU until it is deleted.

Engine trouble warning light indication and fuel injection system operation

Warning light indication	ECU operation	Fuel injection operation	Vehicle operation
Flashing*	Warning provided when unable to start engine	Operation stopped	Cannot be operated
Remains on	Malfunction detected	Operated with substitute characteristics in accordance with the description of the malfunction	Can or cannot be operated depending on the fault code

* The warning light flashes when any one of the conditions listed below is present and the start switch is pushed:

- | | |
|--|---|
| 12: Crankshaft position sensor | 41: Lean angle sensor (open or short-circuit) |
| 19: Blue/black ECU lead (broken or disconnected) | 50: ECU internal malfunction (memory check error) |
| 30: Lean angle sensor (latch up detected) | |

Checking the engine trouble warning light

The engine trouble warning light comes on for 1.4 seconds after the main switch has been turned to "ON" and it comes on while the start switch is being pushed. If the warning light does not come on under these conditions, the warning light (LED) may be defective.

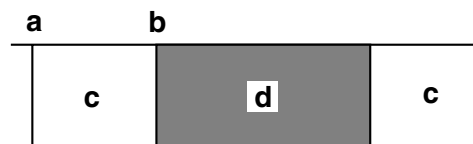

- Main switch "OFF"
- Main switch "ON"
- Engine trouble warning light off
- Engine trouble warning light on for 1.4 seconds

EAS27380

SELF-DIAGNOSTIC FUNCTION TABLE

If the ECU detects an abnormal signal from a sensor while the vehicle is being driven, the ECU illuminates the engine trouble warning light and provides the engine with alternate operating instructions that are appropriate for the type of malfunction.

When an abnormal signal is received from a sensor, the ECU processes the specified values that are programmed for each sensor in order to provide the engine with alternate operating instructions that enable the engine to continue to operate or stop operating, depending on the conditions.

Self-Diagnostic Function table

Fault code No.	Item	Symptom	Able / unable to start	Able / unable to drive
12	Crankshaft position sensor	No normal signals are received from the crankshaft position sensor.	Unable	Unable
13	Cylinder-#1 intake air pressure sensor (open or short circuit)	Cylinder-#1 intake air pressure sensor: open or short circuit detected.	Able	Able
14	Cylinder-#1 intake air pressure sensor (hose system)	Cylinder-#1 intake air pressure sensor: hose system malfunction (clogged or detached hose).	Able	Able
15	Throttle position sensor (open or short circuit)	Throttle position sensor: open or short circuit detected.	Able	Able
17	EXUP servo motor circuit (open or short circuit)	EXUP servo motor circuit: open or short circuit detected.	Able	Able
18	EXUP servo motor (lock)	EXUP servo motor is stuck.	Able	Able
19	Blue/black ECU lead (broken or disconnected)	A break or disconnection of the blue/black lead of the ECU is detected.	Unable	Unable
22	Air temperature sensor (open or short circuit)	Air temperature sensor: open or short circuit detected.	Able	Able
24	O ₂ sensor	No normal signal is received from the O ₂ sensor.	Able	Able
25	Cylinder-#2 intake air pressure sensor (open or short circuit)	Cylinder-#2 intake air pressure sensor: open or short circuit detected.	Able	Able
26	Cylinder-#2 intake air pressure sensor (hose system)	Cylinder-#2 intake air pressure sensor: hose system malfunction (clogged or detached hose).	Able	Able
28	Engine temperature sensor (open or short circuit)	Engine temperature sensor: open or short circuit detected.	Able	Able
30	Lean angle sensor (latch up detected)	The vehicle has overturned.	Unable	Unable

FUEL INJECTION SYSTEM

Fault code No.	Item	Symptom	Able / unable to start	Able / unable to drive
33	Cylinder-#1 left or right ignition coil (faulty ignition)	Malfunction detected in the primary wire of the cylinder-#1 left or right ignition coil.	Able (depending on the number of faulty cylinders)	Able (depending on the number of faulty cylinders)
34	Cylinder-#2 left or right ignition coil (faulty ignition)	Malfunction detected in the primary wire of the cylinder-#2 left or right ignition coil.	Able (depending on the number of faulty cylinders)	Able (depending on the number of faulty cylinders)
35	Cylinder-#1 left or right ignition coil (faulty ignition)	Malfunction detected in the primary wire of the cylinder-#1 left or right ignition coil.	Able (depending on the number of faulty cylinders)	Able (depending on the number of faulty cylinders)
36	Cylinder-#2 left or right ignition coil (faulty ignition)	Malfunction detected in the primary wire of the cylinder-#2 left or right ignition coil.	Able (depending on the number of faulty cylinders)	Able (depending on the number of faulty cylinders)
37	ISC valve (stuck fully open)	Engine speed is high when the engine is idling.	Able	Able
41	Lean angle sensor (open or short circuit)	Lean angle sensor: open or short circuit detected.	Unable	Unable
42	Speed sensor	No normal signals are received from the speed sensor.	Able	Able
	Neutral switch	Open or short circuit is detected in the neutral switch.		
43	Fuel system voltage (monitoring voltage)	The ECU is unable to monitor the battery voltage (an open or short circuit in the line to the ECU).	Able	Able
44	Error in writing the amount of CO adjustment on EEPROM	Error is detected while reading or writing on EEPROM (CO adjustment value).	Able	Able
46	Vehicle system power supply (Monitoring voltage)	Power supply to the fuel injection system is not normal.	Able	Able
50	ECU internal malfunction (memory check error)	Faulty ECU memory. (When this malfunction is detected in the ECU, the fault code number might not appear on the meter.)	Unable	Unable

5. Erase the malfunction history in the diagnostic mode. Refer to "Sensor operation table (Diagnostic code No. 62)".

NOTE:

Turning the main switch to "OFF" will not erase the malfunction history.

The engine operation is not normal but the engine trouble warning light does not come on.

1. Check the operation of following sensors and actuators in the Diagnostic mode. Refer to "Sensor operation table" and "Actuator operation table".

01: Throttle position sensor (throttle angle)
30: Cylinder-#1 ignition coil
31: Cylinder-#2 ignition coil
32: Cylinder-#1 ignition coil
33: Cylinder-#2 ignition coil
36: Injector #1
37: Injector #2

If a malfunction is detected in the sensors or actuators, repair or replace all faulty parts.

If no malfunction is detected in the sensors and actuators, check and repair inner parts of the engine.

EAS27420

DIAGNOSTIC MODE

Setting the diagnostic mode

1. Turn the main switch to "OFF" and set the engine stop switch to "○".
2. Disconnect the wire harness coupler from the fuel pump.
3. Press and hold the "RESET" switch, turn the main switch to "ON", and continue to press the switch for 8 seconds or more.

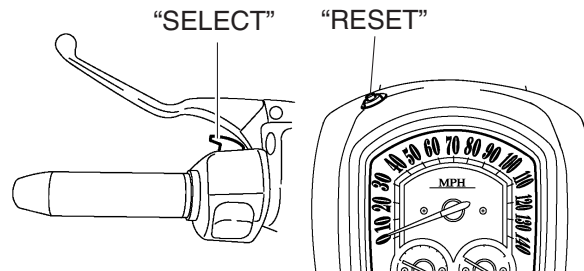

NOTE:

- All displays on the meter disappear except the clock and odometer/trip meter/fuel reserve trip meter/clock displays.
- "dIAG" appears on the odometer/trip meter/fuel reserve trip meter/clock LCD.

4. Simultaneously press the "SELECT" and "RESET" switches for 2 seconds or more to activate the diagnostic mode. The diagnostic code number "d01" appears on the clock LCD.
5. Set the engine stop switch to "⊗".
6. Select the diagnostic code number corresponding to the fault code number by pressing the "SELECT" and "RESET" switches.

NOTE:

- To decrease the selected diagnostic code number, press the "RESET" switch. Press the "RESET" switch for 1 second or longer to automatically decrease the diagnostic code numbers.
- To increase the selected diagnostic code number, press the "SELECT" switch. Press the "SELECT" switch for 1 second or longer to automatically increase the diagnostic code numbers.

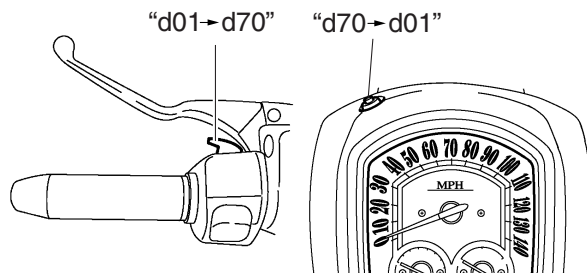

7. Verify the operation of the sensor or actuator.

- Sensor operation

The data representing the operating conditions of the sensor appears on the odometer/trip meter/fuel reserve trip meter/clock LCD.

- Actuator operation

Set the engine stop switch to “○” to operate the actuator.

NOTE:

If the engine stop switch is set to “○”, set it to “⊗”, and then set it to “○” again.

8. Turn the main switch to “OFF” to cancel the diagnostic mode.

Diagnostic code table

Fault code No.	Symptom	Probable cause of malfunction	Diagnostic code No.
12	No normal signals are received from the crankshaft position sensor.	<ul style="list-style-type: none"> • Open or short circuit in wire harness. • Defective crankshaft position sensor. • Malfunction in crankshaft position sensor rotor. • Malfunction in ECU. • Improperly installed sensor. 	—
13	Cylinder-#1 intake air pressure sensor: open or short circuit detected.	<ul style="list-style-type: none"> • Open or short circuit in wire harness. • Defective cylinder-#1 intake air pressure sensor. • Malfunction in ECU. 	03
14	Cylinder-#1 intake air pressure sensor: hose system malfunction (clogged or detached hose).	<ul style="list-style-type: none"> • Cylinder-#1 intake air pressure sensor hose is detached, clogged, kinked, or pinched. • Malfunction in ECU. 	03
15	Throttle position sensor: open or short circuit detected.	<ul style="list-style-type: none"> • Open or short circuit in wire sub lead. • Open or short circuit in wire harness. • Defective throttle position sensor. • Malfunction in ECU. • Improperly installed throttle position sensor. 	01
17	EXUP servo motor circuit: open or short circuit detected.	<ul style="list-style-type: none"> • Open or short circuit in wire harness. • Defective EXUP servo motor (potentiometer circuit). 	53
18	EXUP servo motor is stuck.	<ul style="list-style-type: none"> • Open or short circuit in wire harness. • Stuck EXUP servo motor (mechanism). • Stuck EXUP servo motor (motor). 	53

FUEL INJECTION SYSTEM

Fault code No.	Symptom	Probable cause of malfunction	Diagnostic code No.
19	A break or disconnection of the blue/black lead of the ECU is detected.	<ul style="list-style-type: none"> • Open circuit in wire harness (ECU coupler). • Malfunction in ECU. 	20
22	Air temperature sensor: open or short circuit detected.	<ul style="list-style-type: none"> • Open or short circuit in wire harness. • Defective air temperature sensor. • Malfunction in ECU. • Improperly installed air temperature sensor. 	05
24	No normal signal is received from the O ₂ sensor.	<ul style="list-style-type: none"> • Open or short circuit in wire harness. • Defective O₂ sensor. • Malfunction in ECU. • Improperly installed sensor. 	—
25	Cylinder-#2 intake air pressure sensor: open or short circuit detected.	<ul style="list-style-type: none"> • Open or short circuit in wire sub lead. • Open or short circuit in wire harness. • Defective cylinder-#2 intake air pressure sensor. • Malfunction in ECU. 	04
26	Cylinder-#2 intake air pressure sensor: hose system malfunction (clogged or detached hose).	<ul style="list-style-type: none"> • Cylinder-#2 intake air pressure sensor hose is detached, clogged, kinked, or pinched. • Malfunction in ECU. 	04
28	Engine temperature sensor: open or short circuit detected.	<ul style="list-style-type: none"> • Open or short circuit in wire sub lead. • Open or short circuit in wire harness. • Defective engine temperature sensor. • Malfunction in ECU. • Improperly installed sensor. 	11
30	The vehicle has overturned.	<ul style="list-style-type: none"> • Overturned. • Malfunction in ECU. 	08
33	Malfunction detected in the primary wire of the cylinder-#1 left or right ignition coil.	<ul style="list-style-type: none"> • Open or short circuit in wire harness. • Malfunction in cylinder-#1 left or right ignition coil. • Malfunction in ECU. • Malfunction in a component of ignition cut-off circuit system. 	30 32
34	Malfunction detected in the primary wire of the cylinder-#2 left or right ignition coil.	<ul style="list-style-type: none"> • Open or short circuit in wire sub lead. • Open or short circuit in wire harness. • Malfunction in cylinder-#2 left or right ignition coil. • Malfunction in ECU. • Malfunction in a component of ignition cut-off circuit system. 	31 33
35	Malfunction detected in the primary wire of the cylinder-#1 left or right ignition coil.	<ul style="list-style-type: none"> • Open or short circuit in wire harness. • Malfunction in cylinder-#1 left or right ignition coil. • Malfunction in ECU. • Malfunction in a component of ignition cut-off circuit system. 	30 32

FUEL INJECTION SYSTEM

Fault code No.	Symptom	Probable cause of malfunction	Diagnostic code No.
36	Malfunction detected in the primary wire of the cylinder-#2 left or right ignition coil.	<ul style="list-style-type: none"> • Open or short circuit in wire sub lead. • Open or short circuit in wire harness. • Malfunction in cylinder-#2 left or right ignition coil. • Malfunction in ECU. • Malfunction in a component of ignition cut-off circuit system. 	31 33
37	Engine speed is high when the engine is idling.	<ul style="list-style-type: none"> • Open circuit in wire harness. • Malfunction in throttle body. • Malfunction in throttle cables. • ISC valve is stuck fully open due to disconnected ISC unit hose or coupler. (High engine idle speed is detected with the ISC valve stuck fully open even though signals for the valve to close are continuously being transmitted by the ECU.) • Malfunction in ECU. • ECU fuse is blown. (for XV19S(C)/ XV19M(C)/ XV19CTS(C)/ XV19CTM(C)) 	54
41	Lean angle sensor: open or short circuit detected.	<ul style="list-style-type: none"> • Open or short circuit in wire harness. • Defective lean angle sensor. • Malfunction in ECU. 	08
42	No normal signals are received from the speed sensor. Open circuit is detected in the neutral switch.	<ul style="list-style-type: none"> • Open circuit in wire harness. • Defective speed sensor. • Malfunction in vehicle speed sensor detected. • Defective neutral switch. • Malfunction in the engine side of the neutral switch. • Malfunction in ECU. 	07 21
43	The ECU is unable to monitor the battery voltage (an open or short circuit in the line to the ECU).	<ul style="list-style-type: none"> • Open or short circuit in wire harness. • Malfunction in ECU. 	09
44	Error is detected while reading or writing on EEPROM (CO adjustment value).	<ul style="list-style-type: none"> • Malfunction in ECU. (The CO adjustment value is not properly written on or read from the internal memory). 	60
46	Power supply to the fuel injection system is not normal.	Malfunction in the charging system. Refer to "CHARGING SYSTEM" on page 7-13.	—
50	Faulty ECU memory. (When this malfunction is detected in the ECU, the fault code number might not appear on the meter.)	<ul style="list-style-type: none"> • Malfunction in ECU. (The program and data are not properly written on or read from the internal memory.) 	—

FUEL INJECTION SYSTEM

Fault code No.	Symptom	Probable cause of malfunction	Diagnostic code No.
Er-1	No signals are received from the ECU.	<ul style="list-style-type: none"> • Open or short circuit in wire harness. • Malfunction in meter. • Malfunction in ECU. • Defective wire connection of the ECU coupler. 	—
Er-2	No signals are received from the ECU within the specified duration.	<ul style="list-style-type: none"> • Improper connection in wire harness. • Malfunction in meter. • Malfunction in ECU. 	—
Er-3	Data from the ECU cannot be received correctly.	<ul style="list-style-type: none"> • Improper connection in wire harness. • Malfunction in meter. • Malfunction in ECU. 	—
Er-4	Non-registered data has been received from the meter.	<ul style="list-style-type: none"> • Improper connection in wire harness. • Malfunction in meter. • Malfunction in ECU. 	—

Sensor operation table

Diagnostic code No.	Item	Meter display	Checking method
01	Throttle angle <ul style="list-style-type: none"> • Fully closed position • Fully opened position 	12–22 87–107	Check with throttle fully closed. Check with throttle fully open.
03	Pressure difference (atmospheric pressure and cylinder-#1 intake air pressure)	Displays the cylinder-#1 intake air pressure.	Set the engine stop switch to “○”, and then push the start switch “⊗”. (If the display value changes, the performance is OK.)
04	Pressure difference (atmospheric pressure and cylinder-#2 intake air pressure)	Displays the cylinder-#2 intake air pressure.	Set the engine stop switch to “○”, and then push the start switch “⊗”. (If the display value changes, the performance is OK.)
05	Air temperature	Displays the air temperature.	Compare the actually measured air temperature with the meter display value.
07	Vehicle speed pulse	0–999	Check that the number increases when the rear wheel is rotated. The number is cumulative and does not reset each time the wheel is stopped.
08	Lean angle sensor <ul style="list-style-type: none"> • Upright • Overturned 	0.4–1.4 3.7–4.4	Remove the lean angle sensor and incline it more than 65 degrees.

FUEL INJECTION SYSTEM

Diagnostic code No.	Item	Meter display	Checking method
09	Fuel system voltage (battery voltage)	Approximately 12.0	Set the engine stop switch to “○”, and then compare with the actually measured battery voltage. (If the battery voltage is lower, perform recharging.)
11	Engine temperature	Displays the engine temperature.	Compare the actually measured engine temperature with the meter display value.
20	Sidestand switch <ul style="list-style-type: none"> • Stand retracted • Stand extended 	ON OFF	Set on/off the sidestand switch (with the transmission in gear).
21	Neutral switch <ul style="list-style-type: none"> • Neutral • In gear 	ON OFF	Shift the transmission.
53	EXUP servo motor	Displays the operating angle. Engine trouble warning light comes on twice: once when the EXUP valve is closing and once when it is opening.	—
60	EEPROM fault code display <ul style="list-style-type: none"> • No history • History exists 	00 01 or 02 (Cylinder fault code) • (If both cylinders are defective, the display alternates every two seconds.)	—
61	Malfunction history code display <ul style="list-style-type: none"> • No history • History exists 	00 Fault codes 12-70 • (If more than one code number is detected, the display alternates every two seconds to show all the detected code numbers. When all code numbers are shown, the display repeats the same process.)	—
62	Malfunction history code erasure <ul style="list-style-type: none"> • No history • History exists 	0 Up to 25 fault codes	— To erase the history, set the engine stop switch to “○”.

FUEL INJECTION SYSTEM

Diagnostic code No.	Item	Meter display	Checking method
70	Control number	0-255	—

Actuator operation table

Diagnostic code No.	Item	Actuation	Checking method
30	Cylinder-#1 left or right ignition coil	Actuates the cylinder-#1 left or right ignition coil five times at one-second intervals. Illuminates the engine trouble warning light.	Check the spark five times. • Connect an ignition checker.
31	Cylinder-#2 left or right ignition coil	Actuates the cylinder-#2 left or right ignition coil five times at one-second intervals. Illuminates the engine trouble warning light.	Check the spark five times. • Connect an ignition checker.
32	Cylinder-#1 left or right ignition coil	Actuates the cylinder-#1 left or right ignition coil five times at one-second intervals. Illuminates the engine trouble warning light.	Check the spark five times. • Connect an ignition checker.
33	Cylinder-#2 left or right ignition coil	Actuates the cylinder-#2 left or right ignition coil five times at one-second intervals. Illuminates the engine trouble warning light.	Check the spark five times. • Connect an ignition checker.
36	Injector #1	Actuates the injector #1 five times at one-second intervals. Illuminates the engine trouble warning light.	Check the operating sound of the injector #1 five times.
37	Injector #2	Actuates the injector #2 five times at one-second intervals. Illuminates the engine trouble warning light.	Check the operating sound of the injector #2 five times.
50	Fuel pump relay	Actuates the fuel pump relay five times at one-second intervals. Illuminates the engine trouble warning light. (The engine trouble warning light is OFF when the relay is ON, and the engine trouble warning light is ON when the relay is OFF).	Check the operating sound of the fuel pump relay five times.

FUEL INJECTION SYSTEM

Diagnostic code No.	Item	Actuation	Checking method
52	Headlight relay	Actuates the headlight relay for five cycles of five seconds. (ON 2 seconds, OFF 3 seconds) Illuminates the engine trouble warning light and headlight.	Check the operating sound of the headlight relay five times.
54	ISC valve	Actuates and fully closes the ISC valve, then opens it to the standby opening position when the engine is started. This operation takes approximately 12 seconds until it is completed. Illuminates the engine trouble warning light.	The ISC unit vibrates when the ISC valve operates.

EAS27460

TROUBLESHOOTING DETAILS

This section describes the measures per fault code number displayed on the meter. Check and service the items or components that are the probable cause of the malfunction following the order given.

After the check and service of the malfunctioning part has been completed, reset the meter display according to the reinstatement method.

Fault code No.:

Code number displayed on the meter when the engine failed to work normally. Refer to "Self-Diagnostic Function table".

Diagnostic code No.:

Diagnostic code number to be used when the diagnostic mode is operated. Refer to "DIAGNOSTIC MODE" on page 7-33.

FUEL INJECTION SYSTEM

Fault code No.	12	Symptom	No normal signals are received from the crankshaft position sensor.	
Diagnostic code No.	—	—		
Order	Item/components and probable cause		Check or maintenance job	Reinstatement method
1	Installed condition of crankshaft position sensor.		Check for looseness or pinching.	Cranking the engine.
2	Connections <ul style="list-style-type: none"> • Crankshaft position sensor coupler • Main wire harness ECU coupler 		<ul style="list-style-type: none"> • Check the coupler for any pins that may be pulled out. • Check the locking condition of the coupler. • If there is a malfunction, repair it and connect the coupler securely. 	
3	Open or short circuit in wire harness.		<ul style="list-style-type: none"> • Repair or replace if there is an open or short circuit. • Between the crankshaft position sensor coupler and ECU coupler. (gray–gray) (black/blue–black/blue) 	
4	Defective crankshaft position sensor.		<ul style="list-style-type: none"> • Replace if defective. Refer to “CHECKING THE CRANKSHAFT POSITION SENSOR” on page 7-84. 	

FUEL INJECTION SYSTEM

Fault code No.	13	Symptom	Cylinder-#1 intake air pressure sensor: open or short circuit detected.	
Diagnostic code No.	03	Cylinder-#1 intake air pressure sensor		
Order	Item/components and probable cause		Check or maintenance job	Reinstatement method
1	Connections <ul style="list-style-type: none"> • Cylinder-#1 intake air pressure sensor coupler • Main wire harness ECU coupler 		<ul style="list-style-type: none"> • Check the coupler for any pins that may be pulled out. • Check the locking condition of the coupler. • If there is a malfunction, repair it and connect the coupler securely. 	Turning the main switch to "ON".
2	Open or short circuit in wire harness.		<ul style="list-style-type: none"> • Repair or replace if there is an open or short circuit. • Between cylinder-#1 intake air pressure sensor coupler and ECU coupler (black/blue–black/blue) (pink/white–pink/white) (blue–blue) 	
3	Defective cylinder-#1 intake air pressure sensor.		<ul style="list-style-type: none"> • Execute the diagnostic mode. (Code No.03) • Replace if defective. Refer to "CHECKING THE INTAKE AIR PRESSURE SENSOR" on page 7-91. 	

FUEL INJECTION SYSTEM

Fault code No.	14	Symptom	Cylinder-#1 intake air pressure sensor: hose system malfunction (clogged or detached hose).	
Diagnostic code No.	03	Cylinder-#1 intake air pressure sensor		
Order	Item/components and probable cause		Check or maintenance job	Reinstatement method
1	Cylinder-#1 intake air pressure sensor hose		<ul style="list-style-type: none"> • Check the cylinder-#1 intake air pressure sensor hose condition. • Repair or replace the sensor hose. 	Starting the engine and operating it at idle.
2	Cylinder-#1 intake air pressure sensor malfunction at intermediate electrical potential.		<ul style="list-style-type: none"> • Check and repair the connection. • Replace it if there is a malfunction. 	
3	Connections <ul style="list-style-type: none"> • Cylinder-#1 intake air pressure sensor coupler • Main wire harness ECU coupler 		<ul style="list-style-type: none"> • Check the coupler for any pins that may be pulled out. • Check the locking condition of the coupler. • If there is a malfunction, repair it and connect the coupler securely. 	
4	Defective cylinder-#1 intake air pressure sensor.		<ul style="list-style-type: none"> • Execute the diagnostic mode. (Code No.03) • Replace if defective. Refer to "CHECKING THE INTAKE AIR PRESSURE SENSOR" on page 7-91. 	

FUEL INJECTION SYSTEM

Fault code No.	15	Symptom	Throttle position sensor: open or short circuit detected.	
Diagnostic code No.	01	Throttle position sensor		
Order	Item/components and probable cause	Check or maintenance job	Reinstatement method	
1	Installed condition of throttle position sensor.	<ul style="list-style-type: none"> • Check for looseness or pinching. • Check that the sensor is installed in the specified position. 	Turning the main switch to "ON".	
2	Connections <ul style="list-style-type: none"> • Throttle position sensor coupler • Main wire harness ECU coupler • Sub-wire harness 2 coupler 	<ul style="list-style-type: none"> • Check the coupler for any pins that may be pulled out. • Check the locking condition of the coupler. • If there is a malfunction, repair it and connect the coupler securely. 		
3	Open or short circuit in wire harness and/or sub lead.	<ul style="list-style-type: none"> • Repair or replace if there is an open or short circuit. • Between throttle position sensor coupler and ECU coupler (blue–blue) (yellow–yellow) (black–black) 		
4	Throttle position sensor lead wire open circuit output voltage check.	<ul style="list-style-type: none"> • Check for open circuit and replace the throttle position sensor. (black–yellow) 		
		Open circuit item		
		Ground wire open circuit	5 V	
		Output wire open circuit	0 V	
		Power supply wire open circuit	0 V	
5	Defective throttle position sensor.	<ul style="list-style-type: none"> • Execute the diagnostic mode. (Code No.01) • Replace if defective. Refer to "CHECKING THE THROTTLE POSITION SENSOR" on page 7-89. 		

FUEL INJECTION SYSTEM

Fault code No.	17	Symptom	EXUP servo motor circuit: open or short circuit detected.	
Diagnostic code No.	53	EXUP servo motor		
Order	Item/components and probable cause		Check or maintenance job	Reinstatement method
1	Connections <ul style="list-style-type: none"> • EXUP servo motor coupler • Main wire harness ECU coupler 		<ul style="list-style-type: none"> • Check the coupler for any pins that may be pulled out. • Check the locking condition of the coupler. • If there is a malfunction, repair it and connect the coupler securely. 	Turning the main switch to "ON".
2	Open or short circuit in wire harness.		<ul style="list-style-type: none"> • Repair or replace if there is an open or short circuit. • Between servo motor coupler and ECU coupler (blue–blue) (white/red–white/red) (black/blue–black/blue) 	
3	Defective EXUP servo motor (potentiometer circuit).		<ul style="list-style-type: none"> • Execute the diagnostic mode. (Code No.53) • Replace if defective. Refer to "CHECKING THE EXUP SERVO MOTOR" on page 7-90. 	

Fault code No.	18	Symptom	EXUP servo motor is stuck.	
Diagnostic code No.	53	EXUP servo motor		
Order	Item/components and probable cause		Check or maintenance job	Reinstatement method
1	Connections <ul style="list-style-type: none"> • EXUP servo motor coupler • Main wire harness ECU coupler 		<ul style="list-style-type: none"> • Check the coupler for any pins that may be pulled out. • Check the locking condition of the coupler. • If there is a malfunction, repair it and connect the coupler securely. 	Turning the main switch to "ON". It takes 120 seconds at the maximum before the original state returns.
2	Open or short circuit in wire harness.		<ul style="list-style-type: none"> • Repair or replace if there is an open or short circuit. • Between the EXUP servo motor coupler and the ECU coupler. (black/green–black/green) (black/red–black/red) 	
3	Defective EXUP servo motor.		<ul style="list-style-type: none"> • Execute the diagnostic mode. (Code No.53) • Replace if defective. Refer to "CHECKING THE EXUP SERVO MOTOR" on page 7-90. 	
4	Defective EXUP valve, pulley, cables.		Replace if defective.	

FUEL INJECTION SYSTEM

Fault code No.	19	Symptom	A break or disconnection of the blue/black lead of the ECU is detected.	
Diagnostic code No.	20	Sidestand switch		
Order	Item/components and probable cause		Check or maintenance job	Reinstatement method
1	Connections • Main wire harness ECU coupler		<ul style="list-style-type: none"> • Execute the diagnostic mode. (Code No.20) • Check the coupler for any pins that may be pulled out. • Check the locking condition of the coupler. • If there is a malfunction, repair it and connect the coupler securely. 	If the transmission is in gear, retracting the sidestand. If the transmission is in neutral, reconnecting the wiring.
2	Open or short circuit in wire harness.		<ul style="list-style-type: none"> • Repair or replace if there is an open or short circuit. • Between ECU and blue/black lead 	
3	Defective sidestand switch.		<ul style="list-style-type: none"> • Replace if defective. Refer to "CHECKING THE SWITCHES" on page 7-71. 	

Fault code No.	22	Symptom	Air temperature sensor: open or short circuit detected.	
Diagnostic code No.	05	Air temperature sensor		
Order	Item/components and probable cause		Check or maintenance job	Reinstatement method
1	Installed condition of air temperature sensor.		Check for looseness or pinching.	Turning the main switch to "ON".
2	Connections • Air temperature sensor coupler • Main wire harness ECU coupler		<ul style="list-style-type: none"> • Check the coupler for any pins that may be pulled out. • Check the locking condition of the coupler. • If there is a malfunction, repair it and connect the coupler securely. 	
3	Open or short circuit in wire harness.		<ul style="list-style-type: none"> • Repair or replace if there is an open or short circuit. • Between air temperature sensor coupler and ECU coupler (brown/white–brown/white) (black/blue–black/blue) 	
4	Defective air temperature sensor.		<ul style="list-style-type: none"> • Execute the diagnostic mode. (Code No.05) • Replace if defective. Refer to "CHECKING THE AIR TEMPERATURE SENSOR" on page 7-91. 	

FUEL INJECTION SYSTEM

Fault code No.	24	Symptom	No normal signal is received from the O ₂ sensor.	
Diagnostic code No.	—	—		
Order	Item/components and probable cause	Check or maintenance job	Reinstatement method	
1	Installed state of O ₂ sensor.	Check for looseness or pinching.	Starting the engine and operating it at idle.	
2	Connections <ul style="list-style-type: none"> • O₂ sensor coupler • Main wire harness ECU coupler 	<ul style="list-style-type: none"> • Check the coupler for any pins that may be pulled out. • Check the locking condition of the coupler. • If there is a malfunction, repair it and connect the coupler securely. 		
3	Open or short circuit in wire harness.	<ul style="list-style-type: none"> • Repair or replace if there is an open or short circuit. • Between O₂ sensor coupler and ECU coupler. (gray/white–gray/white) (red/blue–red/blue) (gray/green–gray/green) (black/blue–black/blue) 		
4	Check fuel pressure.	<ul style="list-style-type: none"> • Refer to “THROTTLE BODIES” on page 6-7. 		
5	Defective O ₂ sensor.	<ul style="list-style-type: none"> • Replace if defective. 		

FUEL INJECTION SYSTEM

Fault code No.	25	Symptom	Cylinder-#2 intake air pressure sensor: open or short circuit detected.	
Diagnostic code No.	04	Cylinder-#2 intake air pressure sensor		
Order	Item/components and probable cause		Check or maintenance job	Reinstatement method
1	Connections <ul style="list-style-type: none"> • Cylinder-#2 intake air pressure sensor coupler • Main wire harness ECU coupler • Sub-wire harness 3 coupler 		<ul style="list-style-type: none"> • Check the coupler for any pins that may be pulled out. • Check the locking condition of the coupler. • If there is a malfunction, repair it and connect the coupler securely. 	Turning the main switch to "ON".
2	Open or short circuit in wire harness and/or sub lead.		<ul style="list-style-type: none"> • Repair or replace if there is an open or short circuit. • Between cylinder-#2 intake air pressure sensor coupler and ECU coupler (black/blue–black/blue) (pink/yellow–pink/yellow) (blue–blue) 	
3	Defective cylinder-#2 intake air pressure sensor.		<ul style="list-style-type: none"> • Execute the diagnostic mode. (Code No.04) • Replace if defective. Refer to "CHECKING THE INTAKE AIR PRESSURE SENSOR" on page 7-91. 	

FUEL INJECTION SYSTEM

Fault code No.	26	Symptom	Cylinder-#2 intake air pressure sensor: hose system malfunction (clogged or detached hose).	
Diagnostic code No.	04	Cylinder-#2 intake air pressure sensor		
Order	Item/components and probable cause		Check or maintenance job	Reinstatement method
1	Cylinder-#2 intake air pressure sensor hose		<ul style="list-style-type: none"> • Check the cylinder-#2 intake air pressure sensor hose condition. • Repair or replace the sensor hose. 	Starting the engine and operating it at idle.
2	Cylinder-#2 intake air pressure sensor malfunction at intermediate electrical potential.		<ul style="list-style-type: none"> • Check and repair the connection. • Replace it if there is a malfunction. 	
3	Connections <ul style="list-style-type: none"> • Cylinder-#2 intake air pressure sensor coupler • Main wire harness ECU coupler 		<ul style="list-style-type: none"> • Check the coupler for any pins that may be pulled out. • Check the locking condition of the coupler. • If there is a malfunction, repair it and connect the coupler securely. 	
4	Defective cylinder-#2 intake air pressure sensor.		<ul style="list-style-type: none"> • Execute the diagnostic mode. (Code No.04) • Replace if defective. Refer to "CHECKING THE INTAKE AIR PRESSURE SENSOR" on page 7-91. 	

FUEL INJECTION SYSTEM

Fault code No.	28	Symptom	Engine temperature sensor: open or short circuit detected.	
Diagnostic code No.	11	Engine temperature sensor		
Order	Item/components and probable cause		Check or maintenance job	Reinstatement method
1	Installed state of engine temperature sensor.		Check for looseness or pinching.	Turning the main switch to "ON".
2	Connections <ul style="list-style-type: none"> • Engine temperature sensor coupler • Main wire harness ECU coupler • Sub-wire harness 2 coupler 		<ul style="list-style-type: none"> • Check the coupler for any pins that may be pulled out. • Check the locking condition of the coupler. • If there is a malfunction, repair it and connect the coupler securely. 	
3	Open or short circuit in wire harness and/or sub lead.		<ul style="list-style-type: none"> • Repair or replace if there is an open or short circuit. • Between engine temperature sensor coupler and ECU coupler (brown–brown) (black–black) 	
4	Defective engine temperature sensor.		<ul style="list-style-type: none"> • Execute the diagnostic mode. (Code No.11) • Replace if defective. Refer to "CHECKING THE ENGINE TEMPERATURE SENSOR" on page 7-87. 	

Fault code No.	30	Symptom	The vehicle has overturned.	
Diagnostic code No.	08	Lean angle sensor		
Order	Item/components and probable cause		Check or maintenance job	Reinstatement method
1	The vehicle has overturned.		Raise the vehicle upright.	Turning the main switch to "ON" (however, the engine cannot be restarted unless the main switch is first turned "OFF").
2	Installed condition of the lean angle sensor.		Check for looseness or pinching.	
3	Connections <ul style="list-style-type: none"> • Lean angle sensor coupler • Main wire harness ECU coupler 		<ul style="list-style-type: none"> • Check the coupler for any pins that may be pulled out. • Check the locking condition of the coupler. • If there is a malfunction, repair it and connect the coupler securely. 	
4	Defective lean angle sensor.		<ul style="list-style-type: none"> • Execute the diagnostic mode. (Code No.08) • Replace if defective. Refer to "CHECKING THE LEAN ANGLE SENSOR" on page 7-85. 	

FUEL INJECTION SYSTEM

Fault code No.	33	Symptom	Malfunction detected in the primary wire of the cylinder-#1 left or right ignition coil.	
Diagnostic code No.	30, 32	Cylinder-#1 left or right ignition coil		
Order	Item/components and probable cause		Check or maintenance job	Reinstatement method
1	Connections <ul style="list-style-type: none"> • Cylinder-#1 left or right ignition coil connector (primary coil side) • Main wire harness ECU coupler 		<ul style="list-style-type: none"> • Check the connector and coupler for any pins that may be pulled out. • Check the locking condition of the connector and coupler. • If there is a malfunction, repair it and connect the coupler securely. 	Starting the engine and operating it at idle.
2	Open or short circuit in wire harness.		<ul style="list-style-type: none"> • Repair or replace if there is an open or short circuit. • Between cylinder-#1 left or right ignition coil connector and ECU coupler/main wire harness. (black/red–blue/red) (orange–orange) 	
3	Defective cylinder-#1 left or right ignition coil.		<ul style="list-style-type: none"> • Execute the diagnostic mode. (Code No.30 or 32) • Test the primary and secondary coils for continuity. • Replace if defective. Refer to “CHECKING THE IGNITION COILS” on page 7-84. 	

FUEL INJECTION SYSTEM

Fault code No.	34	Symptom	Malfunction detected in the primary wire of the cylinder-#2 left or right ignition coil.	
Diagnostic code No.	31, 33	Cylinder-#2 left or right ignition coil		
Order	Item/components and probable cause		Check or maintenance job	Reinstatement method
1	Connections <ul style="list-style-type: none"> • Cylinder-#2 left or right ignition coil connector (primary coil side) • Main wire harness ECU coupler • Sub-wire harness 3 coupler 		<ul style="list-style-type: none"> • Check the connector and coupler for any pins that may be pulled out. • Check the locking condition of the connector and coupler. • If there is a malfunction, repair it and connect the coupler securely. 	Starting the engine and operating it at idle.
2	Open or short circuit in wire harness and/or sub lead.		<ul style="list-style-type: none"> • Repair or replace if there is an open or short circuit. • Between cylinder-#2 left or right ignition coil connector and ECU coupler/main wire harness. (black/red–blue/red) (gray/red–gray/red) 	
3	Defective cylinder-#2 left or right ignition coil.		<ul style="list-style-type: none"> • Execute the diagnostic mode. (Code No.31 or 33) • Test the primary and secondary coils for continuity. • Replace if defective. Refer to “CHECKING THE IGNITION COILS” on page 7-84. 	

FUEL INJECTION SYSTEM

Fault code No.	35	Symptom	Malfunction detected in the primary wire of the cylinder-#1 left or right ignition coil.	
Diagnostic code No.	30, 32	Cylinder-#1 left or right ignition coil		
Order	Item/components and probable cause	Check or maintenance job	Reinstatement method	
1	Connections <ul style="list-style-type: none"> • Cylinder-#1 left or right ignition coil connector (primary coil side) • Main wire harness ECU coupler 	<ul style="list-style-type: none"> • Check the connector and coupler for any pins that may be pulled out. • Check the locking condition of the connector and coupler. • If there is a malfunction, repair it and connect the coupler securely. 	Starting the engine and operating it at idle.	
2	Open or short circuit in wire harness.	<ul style="list-style-type: none"> • Repair or replace if there is an open or short circuit. • Between cylinder-#1 left or right ignition coil connector and ECU coupler/main wire harness. (black/red–blue/red) (orange–orange) 		
3	Defective cylinder-#1 left or right ignition coil.	<ul style="list-style-type: none"> • Execute the diagnostic mode. (Code No.30 or 32) • Test the primary and secondary coils for continuity. • Replace if defective. Refer to “CHECKING THE IGNITION COILS” on page 7-84. 		

FUEL INJECTION SYSTEM

Fault code No.	36	Symptom	Malfunction detected in the primary wire of the cylinder-#2 left or right ignition coil.	
Diagnostic code No.	31, 33	Cylinder-#2 left or right ignition coil		
Order	Item/components and probable cause		Check or maintenance job	Reinstatement method
1	Connections <ul style="list-style-type: none"> • Cylinder-#2 left or right ignition coil connector (primary coil side) • Main wire harness ECU coupler • Sub-wire harness 3 coupler 		<ul style="list-style-type: none"> • Check the connector and coupler for any pins that may be pulled out. • Check the locking condition of the connector and coupler. • If there is a malfunction, repair it and connect the coupler securely. 	Starting the engine and operating it at idle.
2	Open or short circuit in wire harness and/or sub lead.		<ul style="list-style-type: none"> • Repair or replace if there is an open or short circuit. • Between cylinder-#2 left or right ignition coil connector and ECU coupler/main wire harness. (black/red–blue/red) (gray/red–gray/red) 	
3	Defective cylinder-#2 left or right ignition coil.		<ul style="list-style-type: none"> • Execute the diagnostic mode. (Code No.31 or 33) • Test the primary and secondary coils for continuity. • Replace if defective. Refer to “CHECKING THE IGNITION COILS” on page 7-84. 	

FUEL INJECTION SYSTEM

Fault code No.	37	Symptom	Engine speed is high when the engine is idling.	
Diagnostic code No.	54	ISC valve		
Order	Item/components and probable cause		Check or maintenance job	Reinstatement method
1	ECU fuse is blown. (for XV19S(C)/ XV19M(C)/ XV19CTS(C)/ XV19CTM(C))		<ul style="list-style-type: none"> • Check the ECU fuse. (for XV19S(C)/ XV19M(C)/ XV19CTS(C)/ XV19CTM(C)) Refer to "CHECKING THE FUSES" on page 7-75. 	ISC valve returns to its original position by turning the main switch to "ON" and back to "OFF". Reinstated if the engine idle speed is within specification after starting the engine.
2	Throttle valve does not fully close.		<ul style="list-style-type: none"> • Check the throttle bodies. Refer to "THROTTLE BODIES" on page 6-7. • Check the throttle cables. Refer to "ADJUSTING THE THROTTLE CABLE FREE PLAY" on page 3-8. 	
3	ISC valve is stuck fully open due to disconnected ISC unit hose or coupler. (High engine idle speed is detected with the ISC valve stuck fully open even though signals for the valve to close are continuously being transmitted by the ECU.)		<ul style="list-style-type: none"> • Check that the ISC unit hose is not disconnected. • Check that the ISC unit coupler is not disconnected. • The ISC valve is stuck fully open if it does not operate when the main switch is turned "OFF". (Touch the ISC unit with your hand and check if it is vibrating to confirm if the ISC valve is operating.) 	
4	ISC valve is not moving correctly.		<ul style="list-style-type: none"> • Execute the diagnostic mode. (Code No.54) • After the ISC valve is fully closed, it opens to the standby opening position when the engine is started. This operation takes approximately 12 seconds. Start the engine. If the error recurs, replace the throttle body assembly. 	

FUEL INJECTION SYSTEM

Fault code No.	41	Symptom	Lean angle sensor: open or short circuit detected.	
Diagnostic code No.	08	Lean angle sensor		
Order	Item/components and probable cause		Check or maintenance job	Reinstatement method
1	Connections <ul style="list-style-type: none"> • Lean angle sensor coupler • Main wire harness ECU coupler 		<ul style="list-style-type: none"> • Check the coupler for any pins that may be pulled out. • Check the locking condition of the coupler. • If there is a malfunction, repair it and connect the coupler securely. 	Turning the main switch to "ON".
2	Open or short circuit in lead wire.		<ul style="list-style-type: none"> • Repair or replace if there is an open or short circuit. • Between lean angle sensor coupler and ECU coupler. (blue–blue) (yellow/green–yellow/green) (black/blue–black/blue) 	
3	Defective lean angle sensor.		<ul style="list-style-type: none"> • Execute the diagnostic mode. (Code No.08) • Replace if defective. Refer to "CHECKING THE LEAN ANGLE SENSOR" on page 7-85. 	

FUEL INJECTION SYSTEM

Fault code No.	42	Symptom	A. No normal signals are received from the speed sensor. B. Open circuit is detected in the neutral switch.	
Diagnostic code No.	A	07	Speed sensor	
	B	21	Neutral switch	
Order	Item/components and probable cause		Check or maintenance job	Reinstatement method
A-1	Connections <ul style="list-style-type: none"> • Speed sensor coupler • Main wire harness ECU coupler 		<ul style="list-style-type: none"> • Check the coupler for any pins that may be pulled out. • Check the locking condition of the coupler. • If there is a malfunction, repair it and connect the coupler securely. 	Starting the engine, and activating the vehicle speed sensor by operating the vehicle at 20 to 30 km/h.
A-2	Open or short circuit in speed sensor lead.		<ul style="list-style-type: none"> • Repair or replace if there is an open or short circuit. • Between speed sensor coupler and ECU coupler. (blue–blue) (white/yellow–white/yellow) (black/blue–black/blue) 	
A-3	Gear for detecting vehicle speed has broken.		<ul style="list-style-type: none"> • Replace if defective. Refer to “TRANSMISSION” on page 5-112. 	
A-4	Defective speed sensor.		<ul style="list-style-type: none"> • Execute the diagnostic mode. (Code No.07) • Replace if defective. Refer to “CHECKING THE SPEED SENSOR” on page 7-89. 	

FUEL INJECTION SYSTEM

Fault code No.	42	Symptom	A. No normal signals are received from the speed sensor. B. Open circuit is detected in the neutral switch.	
Diagnostic code No.	A	07	Speed sensor	
	B	21	Neutral switch	
Order	Item/components and probable cause		Check or maintenance job	Reinstatement method
B-1	Connections <ul style="list-style-type: none"> • Neutral switch coupler • Main wire harness ECU coupler 		<ul style="list-style-type: none"> • Check the coupler for any pins that may be pulled out. • Check the locking condition of the coupler. • If there is a malfunction, repair it and connect the coupler securely. 	Starting the engine, and activating the vehicle speed sensor by operating the vehicle at 20 to 30 km/h.
B-2	Open circuit in neutral switch lead.		<ul style="list-style-type: none"> • Repair or replace if there is an open circuit. • Between neutral switch coupler and relay unit coupler (fuel pump relay). (sky blue–sky blue) • Between relay unit coupler and main switch. (blue/yellow–blue/yellow) • Between main switch and ECU coupler. (blue/black–blue/black) 	
B-3	Faulty shift drum (neutral detection area).		<ul style="list-style-type: none"> • Replace if defective. Refer to “TRANSMISSION” on page 5-112. 	
B-4	Defective neutral switch.		<ul style="list-style-type: none"> • Execute the diagnostic mode. (Code No.21) • Replace if defective. Refer to “CHECKING THE SWITCHES” on page 7-71. 	

FUEL INJECTION SYSTEM

Fault code No.	43	Symptom	The ECU is unable to monitor the battery voltage (an open or short circuit in the line to the ECU).	
Diagnostic code No.	09	Fuel system voltage		
Order	Item/components and probable cause		Check or maintenance job	Reinstatement method
1	Connections <ul style="list-style-type: none"> • Relay unit coupler (fuel pump relay) • Main wire harness ECU coupler 		<ul style="list-style-type: none"> • Check the coupler for any pins that may be pulled out. • Check the locking condition of the coupler. • If there is a malfunction, repair it and connect the coupler securely. 	Starting the engine and operating it at idle.
2	Open or short circuit in the wire harness.		<ul style="list-style-type: none"> • Repair or replace if there is an open or short circuit. • Between relay unit coupler (fuel pump relay) and ECU coupler. (blue/red–blue/red) (red/blue–red/blue) • Between relay unit coupler (fuel pump relay) and battery terminal. (red–red) • Between relay unit coupler (fuel pump relay) and diode 2 coupler. (for XV19S(C)/ XV19M(C)/ XV19CTS(C)/ XV19CTM(C)) (red/white–red/white) • Between diode 2 coupler and engine stop switch coupler. (for XV19S(C)/ XV19M(C)/ XV19CTS(C)/ XV19CTM(C)) (black/red–black/red) 	
3	Malfunction or open circuit in relay unit (fuel pump relay).		<ul style="list-style-type: none"> • Execute the diagnostic mode. (Code No. 09) • Replace if defective. • If there is no malfunction with the relay unit (fuel pump relay), replace the ECU. 	
Fault code No.	44	Symptom	Error is detected while reading or writing on EEPROM (CO adjustment value).	
Diagnostic code No.	60	EEPROM improper cylinder indication		
Order	Item/components and probable cause		Check or maintenance job	Reinstatement method
1	Malfunction in ECU.		<ul style="list-style-type: none"> • Execute the diagnostic mode. (Code No. 60) <ol style="list-style-type: none"> 1. Check the faulty cylinder. (If multiple cylinders are defective, the number of the faulty cylinders appears alternately at 2-second intervals.) • Replace ECU if defective. 	Turning the main switch to “ON”.

FUEL INJECTION SYSTEM

Fault code No.	46	Symptom	Power supply to the fuel injection system is not normal.	
Diagnostic code No.	—	—		
Order	Item/components and probable cause		Check or maintenance job	Reinstatement method
1	Connections • Main wire harness ECU coupler		<ul style="list-style-type: none"> • Check the coupler for any pins that may be pulled out. • Check the locking condition of the coupler. • If there is a malfunction, repair it and connect the coupler securely. 	Starting the engine and operating it at idle.
2	Faulty battery.		<ul style="list-style-type: none"> • Replace or charge the battery. Refer to “CHECKING AND CHARGING THE BATTERY” on page 7-76. 	
3	Malfunction in rectifier/regulator		<ul style="list-style-type: none"> • Replace if defective. Refer to “CHARGING SYSTEM” on page 7-13. 	
4	Open or short circuit in wire harness.		<ul style="list-style-type: none"> • Repair or replace if there is an open or short circuit. • Between battery and main fuse (red–red) • Between main fuse and main switch (red–red) • Between main switch and ignition fuse (brown/blue–brown/blue) • Between ignition fuse and ECU (red/white–red/white) 	

Fault code No.	50	Symptom	Faulty ECU memory. (When this malfunction is detected in the ECU, the fault code number might not appear on the meter.)	
Diagnostic code No.	—	—		
Order	Item/components and probable cause		Check or maintenance job	Reinstatement method
1	Malfunction in ECU.		Replace the ECU. NOTE: _____ Do not perform this procedure with the main switch turned to “ON”. _____	Turning the main switch to “ON”.

FUEL INJECTION SYSTEM

Fault code No.	Er-1	Symptom	No signals are received from the ECU.	
Diagnostic code No.		—	—	
Order	Item/components and probable cause		Check or maintenance job	Reinstatement method
1	Connections <ul style="list-style-type: none"> • Main wire harness ECU coupler • Main wire harness meter assembly coupler 		<ul style="list-style-type: none"> • Check the coupler for any pins that may be pulled out. • Check the locking condition of the coupler. • If there is a malfunction, repair it and connect the coupler securely. 	Turning the main switch to "ON".
2	Open or short circuit in wire harness.		<ul style="list-style-type: none"> • Repair or replace if there is an open or short circuit. • Between meter assembly coupler and ECU coupler (yellow/blue–yellow/blue) 	
3	Malfunction in meter assembly.		Replace the meter assembly.	
4	Malfunction in ECU.		Replace the ECU.	

Fault code No.	Er-2	Symptom	No signals are received from the ECU within the specified duration.	
Diagnostic code No.		—	—	
Order	Item/components and probable cause		Check or maintenance job	Reinstatement method
1	Connections <ul style="list-style-type: none"> • Main wire harness ECU coupler • Main wire harness meter assembly coupler 		<ul style="list-style-type: none"> • Check the coupler for any pins that may be pulled out. • Check the locking condition of the coupler. • If there is a malfunction, repair it and connect the coupler securely. 	Turning the main switch to "ON".
2	Open or short circuit in wire harness.		<ul style="list-style-type: none"> • Repair or replace if there is an open or short circuit. • Between meter assembly coupler and ECU coupler (yellow/blue–yellow/blue) 	
3	Malfunction in meter assembly.		Replace the meter assembly.	
4	Malfunction in ECU.		Replace the ECU.	

FUEL INJECTION SYSTEM

Fault code No.	Er-3	Symptom	Data from the ECU cannot be received correctly.	
Diagnostic code No.		—	—	
Order	Item/components and probable cause	Check or maintenance job	Reinstatement method	
1	Connections <ul style="list-style-type: none"> • Main wire harness ECU coupler • Main wire harness meter assembly coupler 	<ul style="list-style-type: none"> • Check the coupler for any pins that may be pulled out. • Check the locking condition of the coupler. • If there is a malfunction, repair it and connect the coupler securely. 	Turning the main switch to "ON".	
2	Open or short circuit in wire harness.	<ul style="list-style-type: none"> • Repair or replace if there is an open or short circuit. • Between meter assembly coupler and ECU coupler (yellow/blue–yellow/blue) 		
3	Malfunction in meter assembly.	Replace the meter assembly.		
4	Malfunction in ECU.	Replace the ECU.		

Fault code No.	Er-4	Symptom	Non-registered data has been received from the meter.	
Diagnostic code No.		—	—	
Order	Item/components and probable cause	Check or maintenance job	Reinstatement method	
1	Connections <ul style="list-style-type: none"> • Main wire harness ECU coupler • Main wire harness meter assembly coupler 	<ul style="list-style-type: none"> • Check the coupler for any pins that may be pulled out. • Check the locking condition of the coupler. • If there is a malfunction, repair it and connect the coupler securely. 	Turning the main switch to "ON".	
2	Open or short circuit in wire harness.	<ul style="list-style-type: none"> • Repair or replace if there is an open or short circuit. • Between meter assembly coupler and ECU coupler (yellow/blue–yellow/blue) 		
3	Malfunction in meter assembly.	Replace the meter assembly.		
4	Malfunction in ECU.	Replace the ECU.		

EAS27550

FUEL PUMP SYSTEM

EAS27560

CIRCUIT DIAGRAM

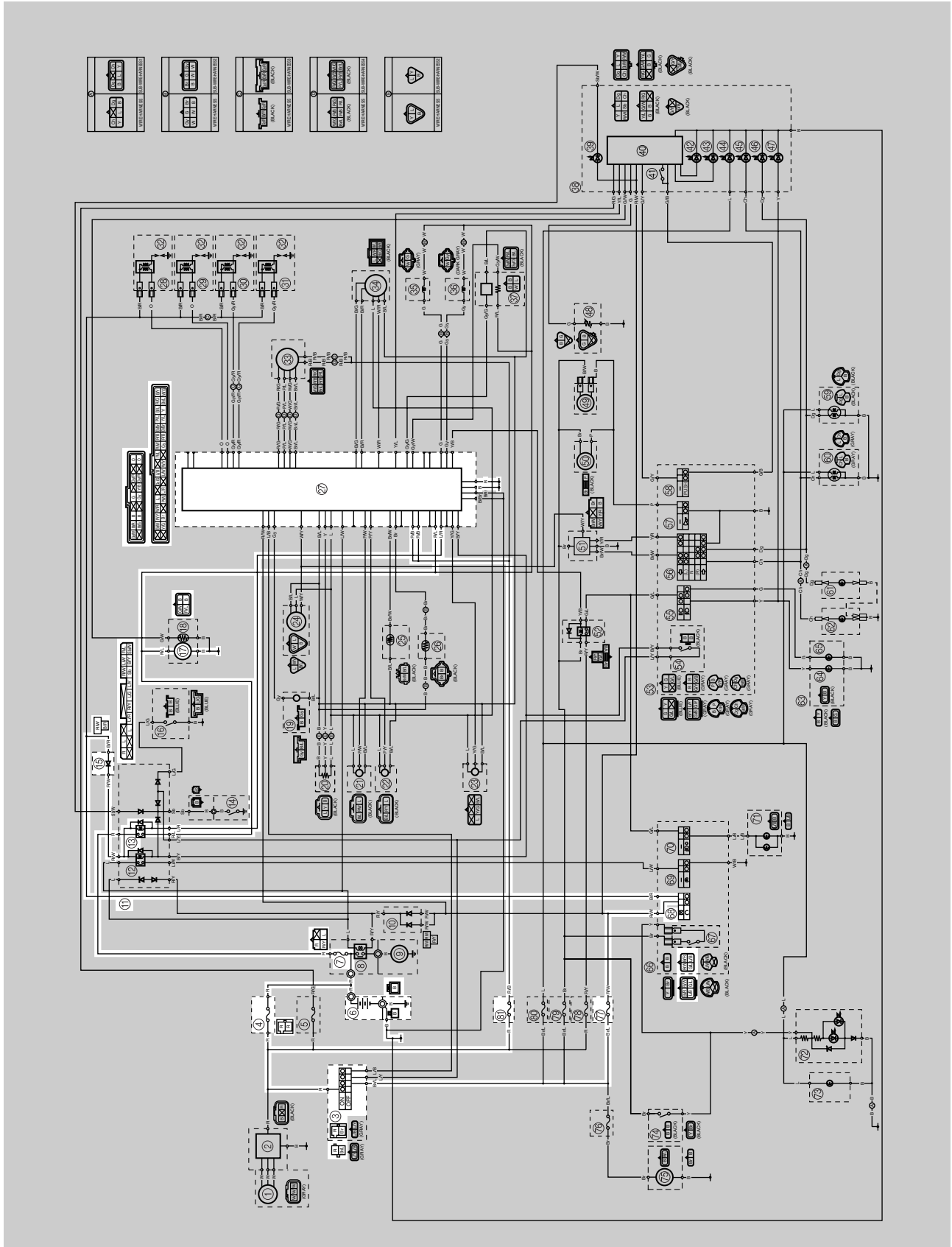

- 3. Main switch
- 4. Main fuse
- 6. Battery
- 7. Fuel injection system fuse
- 11. Relay unit
- 13. Fuel pump relay
- 15. Diode 2 (for XV19S(C)/ XV19M(C)/
XV19CTS(C)/ XV19CTM(C))
- 17. Fuel pump
- 27. ECU (electronic control unit)
- 68. Engine stop switch
- 77. Ignition fuse
- 81. ECU fuse (for XV19S(C)/ XV19M(C)/
XV19CTS(C)/ XV19CTM(C))

EAS27570

TROUBLESHOOTING

If the fuel pump fails to operate.

NOTE:

• Before troubleshooting, remove the following part(s):

1. Rider seat
2. Tool kit tray
3. Rider seat bracket assembly
4. Left side cover
5. Headlight assembly

<p>1. Check the fuses. (Main, fuel injection system, ignition and ECU) Refer to "CHECKING THE FUSES" on page 7-75.</p>	<p>NG →</p>	<p>Replace the fuse(s).</p>
OK ↓		
<p>2. Check the battery. Refer to "CHECKING AND CHARGING THE BATTERY" on page 7-76.</p>	<p>NG →</p>	<ul style="list-style-type: none"> • Clean the battery terminals. • Recharge or replace the battery.
OK ↓		
<p>3. Check the main switch. Refer to "CHECKING THE SWITCHES" on page 7-71.</p>	<p>NG →</p>	<p>Replace the main switch.</p>
OK ↓		
<p>4. Check the engine stop switch. Refer to "CHECKING THE SWITCHES" on page 7-71.</p>	<p>NG →</p>	<p>The engine stop switch is faulty. Replace the right handlebar switch.</p>
OK ↓		
<p>5. Check the relay unit (fuel pump relay). Refer to "CHECKING THE RELAYS" on page 7-79.</p>	<p>NG →</p>	<p>Replace the relay unit.</p>
OK ↓		
<p>6. Check the diode 2. (for XV19S(C)/ XV19M(C)/ XV19CTS(C)/ XV19CTM(C)) Refer to "CHECKING THE DIODES" on page 7-81.</p>	<p>NG →</p>	<p>Replace the diode 2.</p>
OK ↓		
<p>7. Check the fuel pump. Refer to "CHECKING THE FUEL PUMP" on page 7-90.</p>	<p>NG →</p>	<p>Replace the fuel pump assembly.</p>
OK ↓		

8. Check the entire fuel pump system wiring.
Refer to "CIRCUIT DIAGRAM" on page 7-63.

OK ↓

Replace the ECU.

NG →

Properly connect or repair the fuel pump system wiring.

EAS27970

ELECTRICAL COMPONENTS

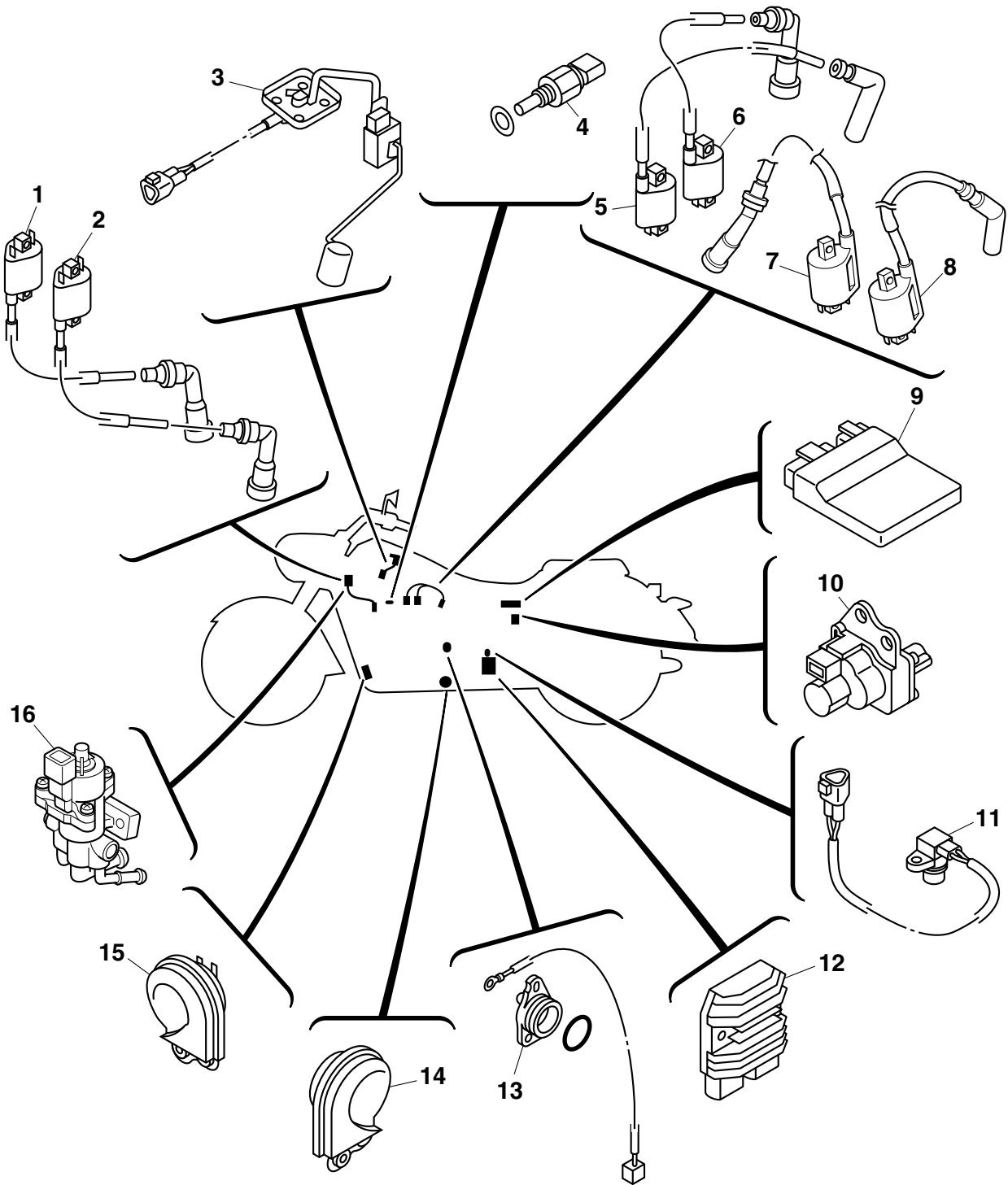

1. Cylinder-#2 right ignition coil (for XV19S(C)/
XV19M(C)/ XV19CTS(C)/ XV19CTM(C))
2. Cylinder-#2 left ignition coil (for XV19S(C)/
XV19M(C)/ XV19CTS(C)/ XV19CTM(C))
3. Fuel sender
4. Engine temperature sensor
5. Cylinder-#1 left ignition coil (for XV19S(C)/
XV19M(C)/ XV19CTS(C)/ XV19CTM(C))
Cylinder-#2 right ignition coil (for XV19CS(C)/
XV19C(C))
6. Cylinder-#1 right ignition coil (for XV19S(C)/
XV19M(C)/ XV19CTS(C)/ XV19CTM(C))
Cylinder-#1 right ignition coil (for XV19CS(C)/
XV19C(C))
7. Cylinder-#2 left ignition coil (for XV19CS(C)/
XV19C(C))
8. Cylinder-#1 left ignition coil (for XV19CS(C)/
XV19C(C))
9. ECU (electronic control unit)
10. EXUP servo motor
11. Speed sensor
12. Rectifier/regulator
13. Neutral switch
14. Horn 2
15. Horn 1
16. ISC (idle speed control) unit

ELECTRICAL COMPONENTS

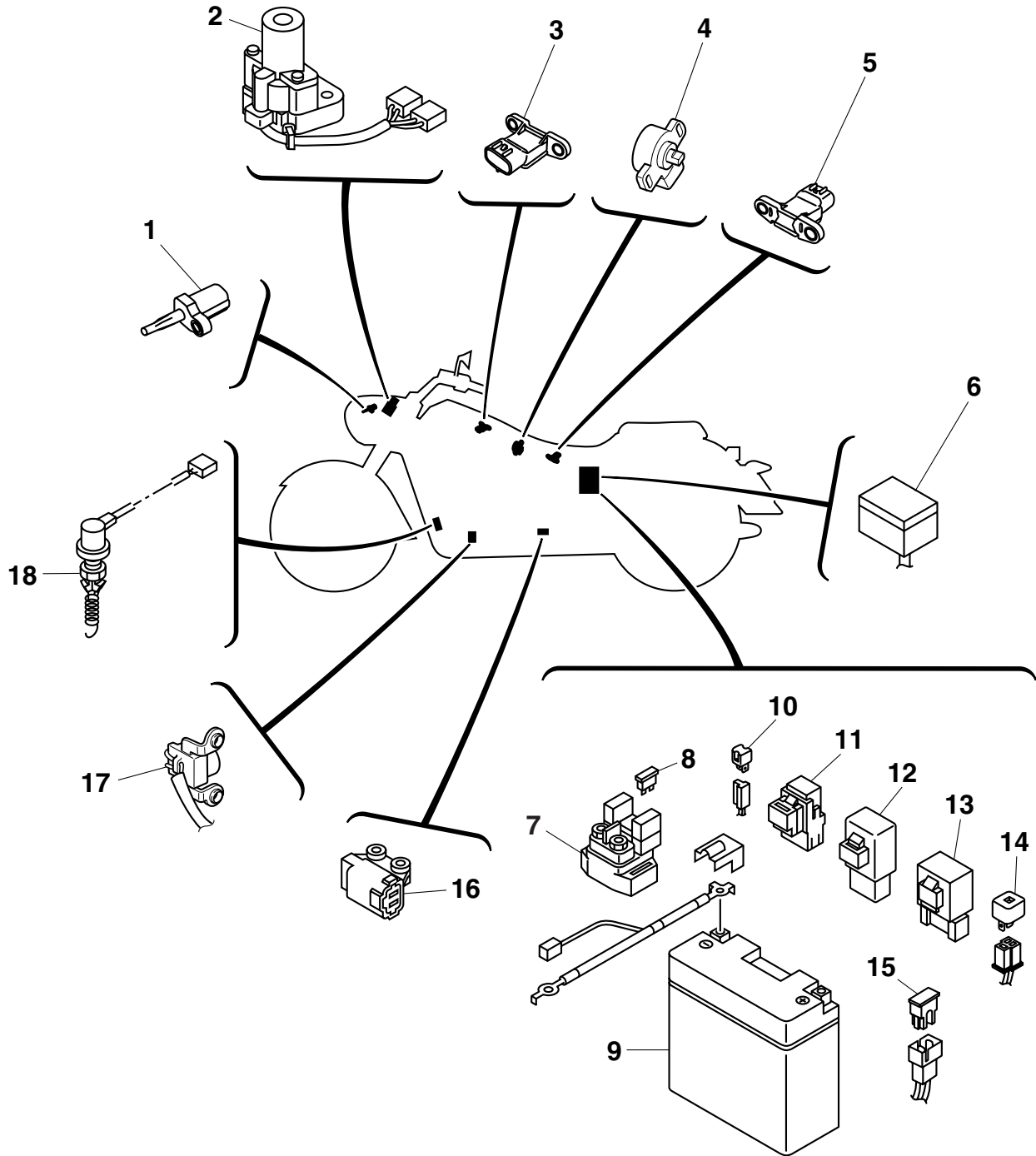

ELECTRICAL COMPONENTS

1. Air temperature sensor
2. Main switch
3. Cylinder-#2 intake air pressure sensor
4. Throttle position sensor
5. Cylinder-#1 intake air pressure sensor
6. Fuse box
7. Starter relay
8. Fuel injection system fuse
9. Battery
10. Diode 2 (for XV19S(C)/ XV19M(C)/
XV19CTS(C)/ XV19CTM(C))
11. Turn signal relay
12. Headlight relay
13. Relay unit
14. Diode 1 (for XV19S(C)/ XV19M(C)/
XV19CTS(C)/ XV19CTM(C))
15. Main fuse
16. Lean angle cut-off switch
17. Crankshaft position sensor
18. Rear brake light switch

EAS27980

CHECKING THE SWITCHES

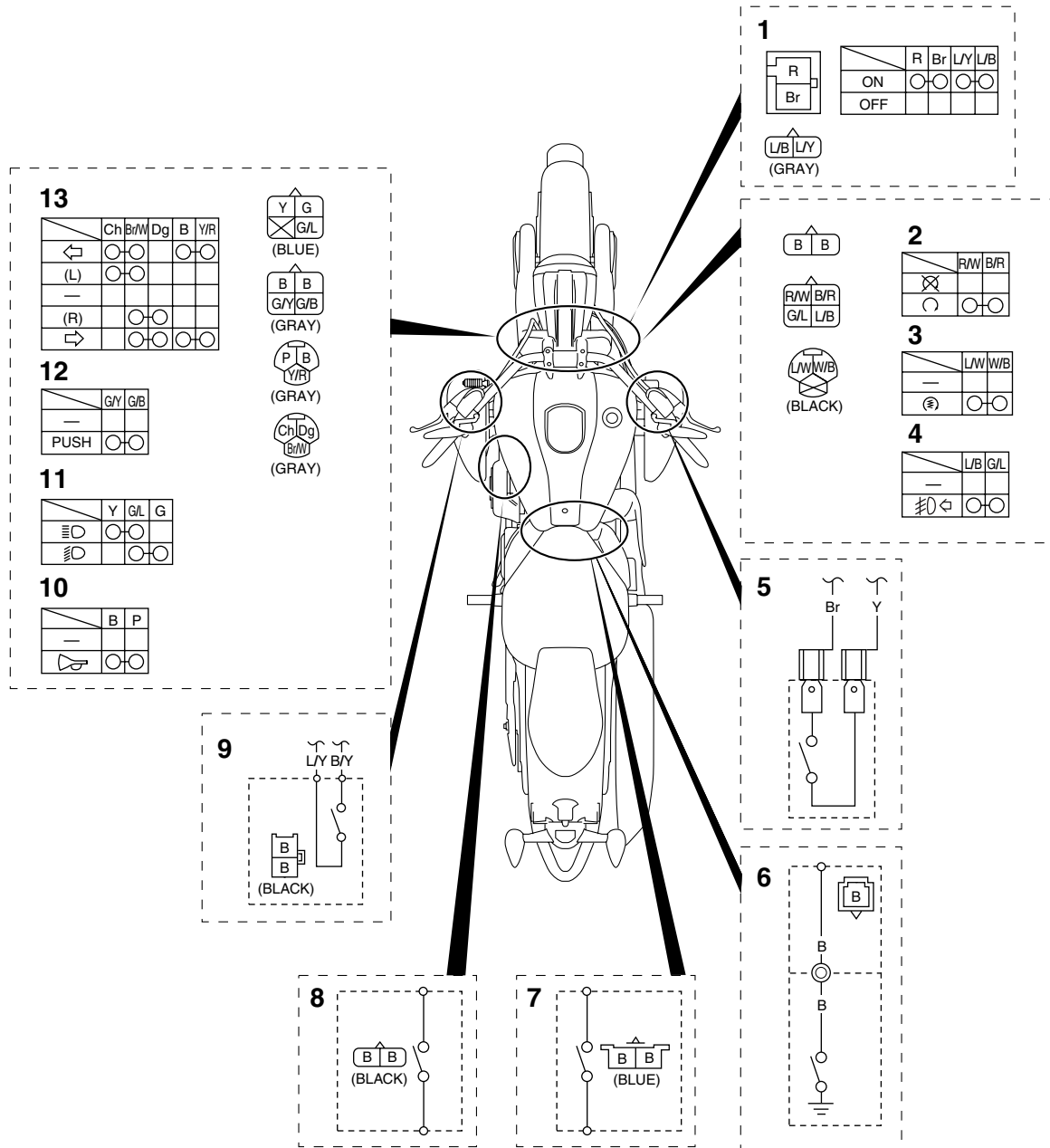

ELECTRICAL COMPONENTS

1. Main switch
2. Engine stop switch
3. Start switch
4. Accessory light switch
5. Front brake light switch
6. Neutral switch
7. Sidestand switch
8. Rear brake light switch
9. Clutch switch
10. Horn switch
11. Dimmer switch
12. Select switch
13. Turn signal switch

ELECTRICAL COMPONENTS

Check each switch for continuity with the pocket tester. If the continuity reading is incorrect, check the wiring connections and if necessary, replace the switch.

ECA14370

CAUTION:

Never insert the tester probes into the coupler terminal slots "a". Always insert the probes from the opposite end of the coupler, taking care not to loosen or damage the leads.



Pocket tester
90890-03112
Analog pocket tester
YU-03112-C

NOTE:

- Before checking for continuity, set the pocket tester to "0" and to the " $\Omega \times 1$ " range.
- When checking for continuity, switch back and forth between the switch positions a few times.

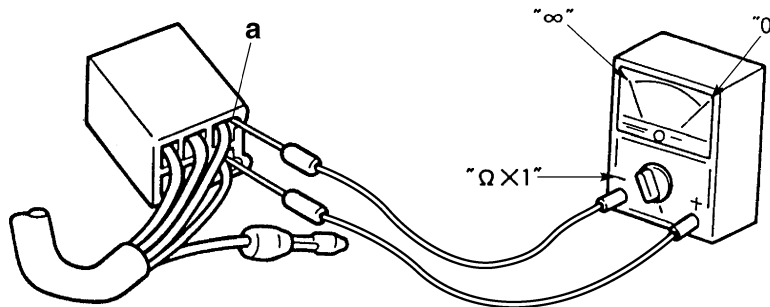

The switches and their terminal connections are illustrated as in the following example of the main switch.

The switch positions "a" are shown in the far left column and the switch lead colors "b" are shown in the top row.

The continuity (i. e., a closed circuit) between switch terminals at a given switch position is indicated by "○—○". There is continuity between red and brown, blue/yellow and blue/black when the switch is set to "ON".

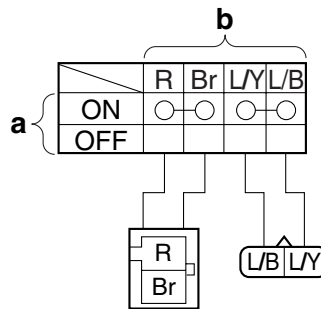

For XV19CS(C)/ XV19C(C)

Fuses	Amperage rating	Q'ty
Main	50 A	1
Ignition	25 A	1
Headlight	20 A	1
Fuel injection system	15 A	1
Signaling system	10 A	1
Taillight	7.5 A	1
Backup (odometer and clock)	7.5 A	1
Auxiliary DC connector	3 A	1
Spare	25 A	1
Spare	20 A	1
Spare	15 A	1
Spare	10 A	1
Spare	7.5 A	1
Spare	3 A	1

EWA13310

WARNING

Never use a fuse with an amperage rating other than that specified. Improvising or using a fuse with the wrong amperage rating may cause extensive damage to the electrical system, cause the lighting and ignition systems to malfunction and could possibly cause a fire.



4. Install:

- Rider seat
Refer to "GENERAL CHASSIS" on page 4-1.

EAS28030

CHECKING AND CHARGING THE BATTERY

EWA13290

WARNING

Batteries generate explosive hydrogen gas and contain electrolyte which is made of poisonous and highly caustic sulfuric acid. Therefore, always follow these preventive measures:

- Wear protective eye gear when handling or working near batteries.
- Charge batteries in a well-ventilated area.
- Keep batteries away from fire, sparks or open flames (e.g., welding equipment, lighted cigarettes).

- **DO NOT SMOKE** when charging or handling batteries.
- **KEEP BATTERIES AND ELECTROLYTE OUT OF REACH OF CHILDREN.**
- Avoid bodily contact with electrolyte as it can cause severe burns or permanent eye injury.

FIRST AID IN CASE OF BODILY CONTACT: EXTERNAL

- **Skin** — Wash with water.
- **Eyes** — Flush with water for 15 minutes and get immediate medical attention.

INTERNAL

- Drink large quantities of water or milk followed with milk of magnesia, beaten egg or vegetable oil. Get immediate medical attention.

EC1D71020

CAUTION:

- This is a sealed battery. Never remove the sealing caps because the balance between cells will not be maintained and battery performance will deteriorate.
- Charging time, charging amperage and charging voltage for an MF battery are different from those of conventional batteries. The MF battery should be charged according to the instructions for the charging method. If the battery is overcharged, the electrolyte level will drop considerably. Therefore, take special care when charging the battery.

NOTE:

Since MF batteries are sealed, it is not possible to check the charge state of the battery by measuring the specific gravity of the electrolyte. Therefore, the charge of the battery has to be checked by measuring the voltage at the battery terminals.

1. Remove:
 - Rider seat
Refer to "GENERAL CHASSIS" on page 4-1.
2. Remove:
 - ECU band "1"

- f. If charging requires more than 5 hours, it is advisable to check the charging current after a lapse of 5 hours. If there is any change in the amperage, readjust the voltage to obtain the standard charging current.
- g. Measure the battery open-circuit voltage after leaving the battery unused for more than 30 minutes.

12.8 V or more --- Charging is complete.
 12.7 V or less --- Recharging is required.
 Under 12.0 V --- Replace the battery.



Charging method using a constant voltage charger

- a. Measure the open-circuit voltage prior to charging.

NOTE:

Voltage should be measured 30 minutes after the engine is stopped.

- b. Connect a charger and ammeter to the battery and start charging.
- c. Make sure that the current is higher than the standard charging current written on the battery.

NOTE:

If the current is lower than the standard charging current written on the battery, this type of battery charger cannot charge the MF battery. A variable voltage charger is recommended.

- d. Charge the battery until the battery's charging voltage is 15 V.

NOTE:

Set the charging time at 20 hours (maximum).

- e. Measure the battery open-circuit voltage after leaving the battery unused for more than 30 minutes.

12.8 V or more --- Charging is complete.
 12.7 V or less --- Recharging is required.
 Under 12.0 V --- Replace the battery.



8. Install:
 - Battery
9. Connect:
 - Battery leads
(to the battery terminals)

ECA13630

CAUTION:

First, connect the positive battery lead "1", and then the negative battery lead "2".

NOTE:

Be sure to route the negative battery lead towards the front of the vehicle and to install the negative terminal cover "3" securely.

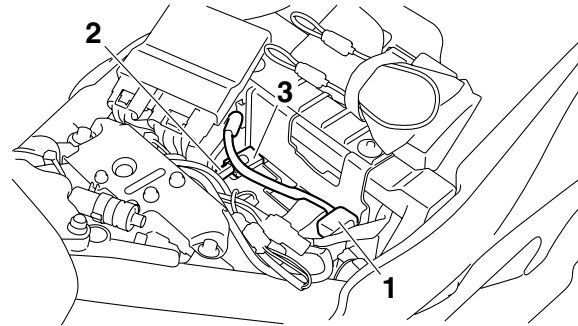

10. Check:
 - Battery terminals
Dirt → Clean with a wire brush.
Loose connection → Connect properly.
11. Lubricate:
 - Battery terminals

	Recommended lubricant Dielectric grease
--	--

12. Install:
 - Coupler tray
 - ECU band

NOTE:

Make sure the leads are routed correctly.

13. Install:
 - Rider seat
Refer to "GENERAL CHASSIS" on page 4-1.

EAS28040

CHECKING THE RELAYS

Check each switch for continuity with the pocket tester. If the continuity reading is incorrect, replace the relay.

	Pocket tester 90890-03112 Analog pocket tester YU-03112-C
--	--

1. Disconnect the relay from the wire harness.
2. Connect the pocket tester ($\Omega \times 1$) and battery (12 V) to the relay terminals as shown. Check the relay operation.
Out of specification → Replace.

Starter relay

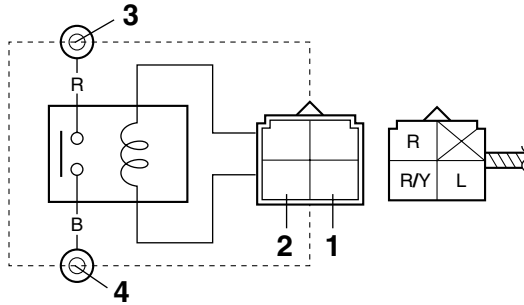

1. Positive battery terminal
2. Negative battery terminal
3. Positive tester probe
4. Negative tester probe



Result
Continuity
(between "3" and "4")

2. Negative battery terminal
3. Positive tester probe
4. Negative tester probe



Result
Continuity
(between "3" and "4")

Headlight relay

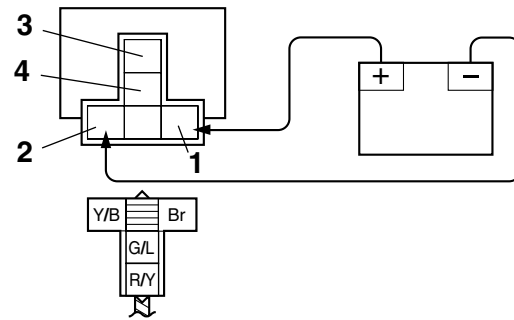

1. Positive battery terminal
2. Negative battery terminal
3. Positive tester probe
4. Negative tester probe



Result
Continuity
(between "3" and "4")

Relay unit (starting circuit cut-off relay)

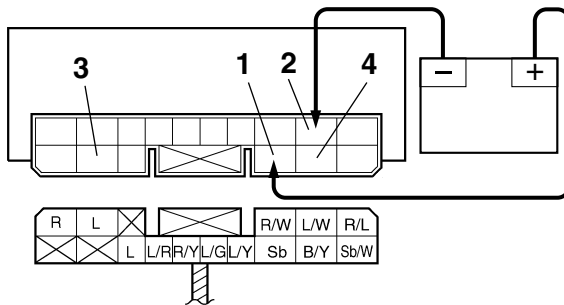

1. Positive battery terminal
2. Negative battery terminal
3. Positive tester probe
4. Negative tester probe



Result
Continuity
(between "3" and "4")

ET1D71011

CHECKING THE TURN SIGNAL RELAY

1. Check:
 - Turn signal relay input voltage
Out of specification → The wiring circuit from the main switch to the turn signal relay coupler is faulty and must be repaired.



Turn signal relay input voltage
DC 12 V

- a. Connect the pocket tester (DC 20 V) to the turn signal relay terminal as shown.



Pocket tester
90890-03112
Analog pocket tester
YU-03112-C

Relay unit (fuel pump relay)

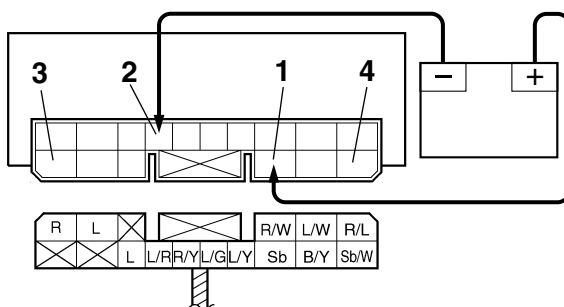

1. Positive battery terminal

- Positive tester probe → brown "1"
- Negative tester probe → ground

EAS28050

CHECKING THE DIODES

Relay unit (diode)

1. Check:
 - Relay unit (diode)
Out of specification → Replace.

	Pocket tester 90890-03112 Analog pocket tester YU-03112-C
---	--

NOTE: _____
 The pocket tester or the analog pocket tester readings are shown in the following table.

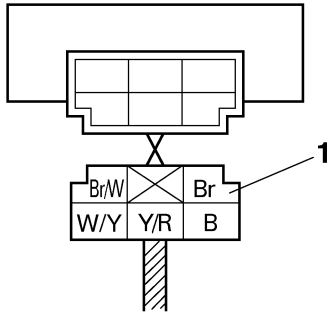

- b. Turn the main switch to “ON”.
- c. Measure the turn signal relay input voltage.



2. Check:
 - Turn signal relay output voltage
Out of specification → Replace.

	Turn signal relay output voltage DC 12 V
---	---



- a. Connect the pocket tester (DC 20 V) to the turn signal relay terminal as shown.

	Pocket tester 90890-03112 Analog pocket tester YU-03112-C
--	--

- Positive tester probe → brown/white “1”, yellow/red “2” or white/yellow “3”
- Negative tester probe → ground

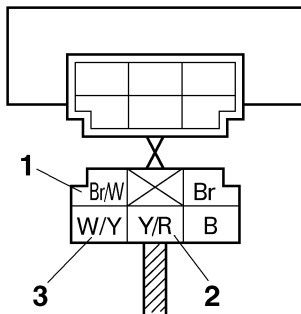

- b. Turn the main switch to “ON”.
- c. Measure the turn signal relay output voltage.





Pocket tester
90890-03112
Analog pocket tester
YU-03112-C

NOTE:

The pocket tester and the analog pocket tester readings are shown in the following table.

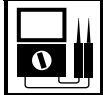

Continuity
Positive tester probe → red/white "1"
Negative tester probe → black/red "2"
No continuity
Positive tester probe → black/red "2"
Negative tester probe → red/white "1"

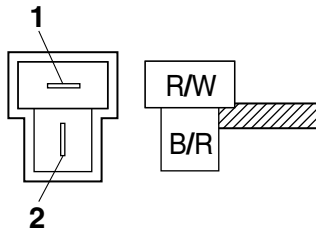

- a. Disconnect the diode 2 from the wire harness.
- b. Connect the pocket tester ($\Omega \times 1$) to the diode 2 terminals as shown.
- c. Check the diode 2 for continuity.
- d. Check the diode 2 for no continuity.

ET1D71012

CHECKING THE IGNITION SPARK GAP

- 1. Check:
 - Ignition spark gap
Out of specification → Perform the ignition system troubleshooting, starting with step 5. Refer to "TROUBLESHOOTING" on page 7-4.



Minimum ignition spark gap
6.0 mm (0.24 in)

NOTE:

If the ignition spark gap is within specification, the ignition system circuit is operating normally.

- a. Disconnect the spark plug cap from the spark plug.
- b. Connect the ignition checker "1" as shown.



Ignition checker
90890-06754
Opama pet-4000 spark checker
YM-34487

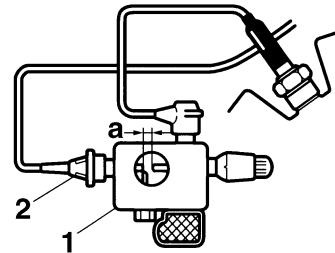

- 2. Spark plug cap
- c. Turn the main switch to "ON" and engine stop switch to "O".
- d. Measure the ignition spark gap "a".
- e. Crank the engine by pushing the start switch "⊕" and gradually increase the spark gap until a misfire occurs.

EAS28070

CHECKING THE SPARK PLUG CAPS

The following procedure applies to all of the spark plug caps.

- 1. Check:
 - Spark plug cap resistance
Out of specification → Replace.



Resistance
10.0 k Ω

- a. Remove the spark plug cap from the spark plug lead.
- b. Connect the pocket tester ($\Omega \times 1k$) to the spark plug cap as shown.



Pocket tester
90890-03112
Analog pocket tester
YU-03112-C

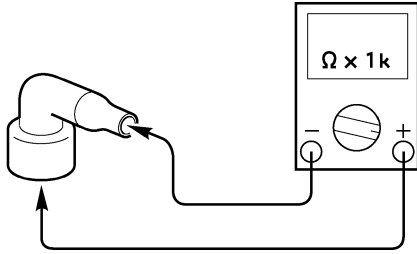

c. Measure the spark plug cap resistance.



EAS28100

CHECKING THE IGNITION COILS

The following procedure applies to all of the ignition coils.

1. Check:

- Primary coil resistance
Out of specification → Replace.



Primary coil resistance
2.16–2.64 Ω

- Disconnect the ignition coil connectors from the ignition coil terminals.
- Connect the pocket tester ($\Omega \times 1$) to the ignition coil as shown.



Pocket tester
90890-03112
Analog pocket tester
YU-03112-C

- Positive tester probe → black/red “1”
- Negative tester probe → orange or gray/red “2”

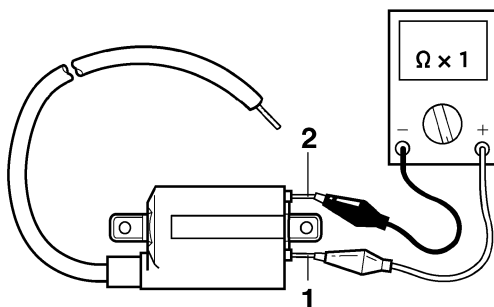

c. Measure the primary coil resistance.



2. Check:

- Secondary coil resistance
Out of specification → Replace.



Secondary coil resistance
8.64–12.96 kΩ

- Disconnect the spark plug cap from the ignition coil.
- Connect the pocket tester ($\Omega \times 1k$) to the ignition coil as shown.



Pocket tester
90890-03112
Analog pocket tester
YU-03112-C

- Negative tester probe → black/red “1”
- Positive tester probe → spark plug lead “2”

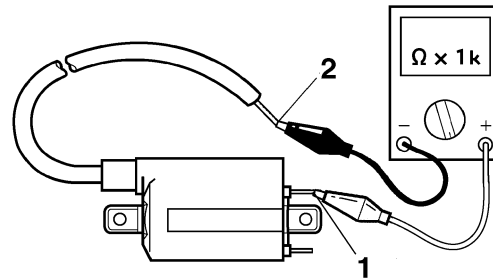

c. Measure the secondary coil resistance.



EAS28120

CHECKING THE CRANKSHAFT POSITION SENSOR

1. Disconnect:

- Crankshaft position sensor coupler (from the wire harness)

2. Check:

- Crankshaft position sensor resistance
Out of specification → Replace the crankshaft position sensor.



Crankshaft position sensor resistance
248–372 Ω

- Connect the pocket tester ($\Omega \times 100$) to the crankshaft position sensor coupler as shown.



Pocket tester
90890-03112
Analog pocket tester
YU-03112-C

- Positive tester probe → gray “1”
- Negative tester probe → black “2”

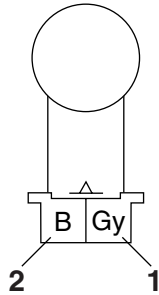

- b. Measure the crankshaft position sensor resistance.



EAS28130

CHECKING THE LEAN ANGLE SENSOR

1. Remove:
 - Lean angle sensor
2. Check:
 - Lean angle sensor output voltage
 Out of specification → Replace.



Lean angle sensor output voltage
 Less than 65°: 0.4–1.4 V
 More than 65°: 3.7–4.4 V

- a. Connect the lean angle sensor coupler to the wire harness.
- b. Connect the pocket tester (DC 20 V) to the lean angle sensor coupler as shown.



Pocket tester
 90890-03112
Analog pocket tester
 YU-03112-C

- Positive tester probe → yellow/green “1”
- Negative tester probe → black/blue “2”

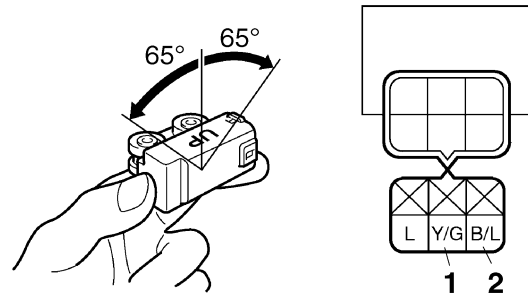

- c. Turn the lean angle sensor to 65°.
- d. Measure the lean angle sensor output voltage.



ET1D71013

CHECKING THE STARTER MOTOR OPERATION

1. Check:
 - Starter motor operation
 Does not operate → Perform the electric starting system troubleshooting, starting with step 5.
 Refer to “TROUBLESHOOTING” on page 7-11.



- a. Connect the positive battery terminal “1” and starter motor lead “2” with a jumper lead “3”.

EWA13810

WARNING

- A wire that is used as a jumper lead must have at least the same capacity of the battery lead, otherwise the jumper lead may burn.
- This check is likely to produce sparks, therefore, make sure no flammable gas or fluid is in the vicinity.

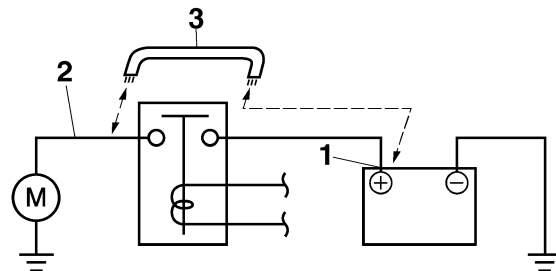

- b. Check the starter motor operation.



EAS28150

CHECKING THE STATOR COIL

1. Disconnect:
 - Stator coil coupler (from the rectifier/regulator)

2. Check:

- Stator coil resistance
Out of specification → Replace the stator coil.

	Stator coil resistance 0.112–0.168 Ω
---	--

a. Connect the pocket tester ($\Omega \times 1$) to the stator coil coupler as shown.

	Pocket tester 90890-03112 Analog pocket tester YU-03112-C
---	--

- Positive tester probe → white “1”
- Negative tester probe → white “2”

- Positive tester probe → white “1”
- Negative tester probe → white “3”

- Positive tester probe → white “2”
- Negative tester probe → white “3”

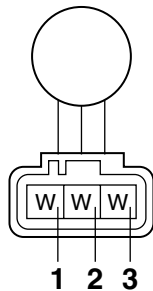

b. Measure the stator coil resistance.

CHECKING THE RECTIFIER/REGULATOR

1. Check:

- Charging voltage
Out of specification → Replace the rectifier/regulator.

	Charging voltage 14 V at 5000 r/min
---	---

a. Set the engine tachometer to the cylinder-#1 left spark plug lead or right spark plug lead.

b. Connect the pocket tester (DC 20 V) to the rectifier/regulator coupler as shown.

	Pocket tester 90890-03112 Analog pocket tester YU-03112-C
---	--

- Positive tester probe → red “1”
- Negative tester probe → black “2”

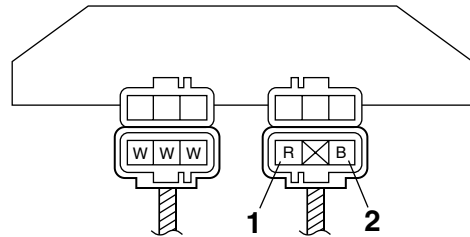

c. Start the engine and let it run at approximately 5000 r/min.

d. Measure the charging voltage.

EAS28180

CHECKING THE HORNS

1. Check:

- Horn resistance
Out of specification → Replace.

	Coil resistance 0.94–0.98 Ω
---	---------------------------------------

a. Disconnect the horn 1 connectors and horn 2 coupler from the horn terminals.

b. Connect the pocket tester ($\Omega \times 1$) to the horn terminals.

	Pocket tester 90890-03112 Analog pocket tester YU-03112-C
---	--

- Positive tester probe → horn terminal “1”
- Negative tester probe → horn terminal “2”

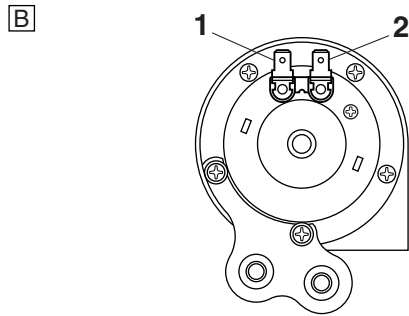
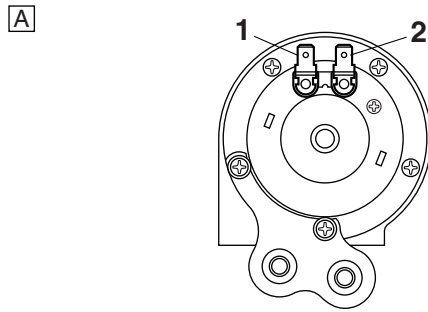

- A. Horn 1
- B. Horn 2

c. Measure the horn resistance.



2. Check:

- Horn sound
- Faulty sound → Adjust or replace.



- a. Connect a battery (12 V) to the horn.
- b. Turn the adjusting screw in direction “a” or “b” until the horn sound is obtained.

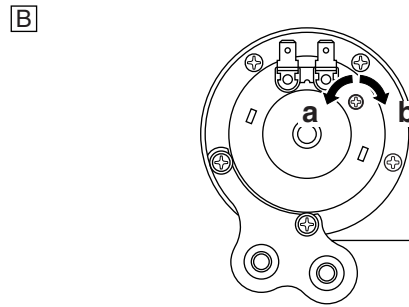
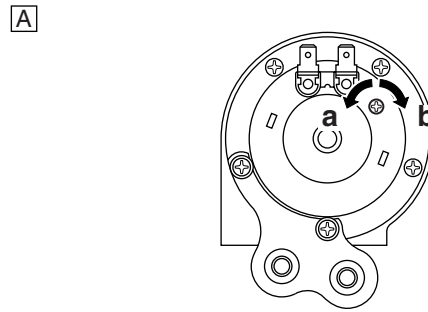

- A. Horn 1
- B. Horn 2



EAS28210

CHECKING THE ENGINE TEMPERATURE SENSOR

1. Remove:

- Engine temperature sensor (from the front cylinder head)

EWA14140



WARNING

- Handle the engine temperature sensor with special care.
- Never subject the engine temperature sensor to strong shocks. If the engine temperature sensor is dropped, replace it.

2. Check:

- Engine temperature sensor resistance
- Out of specification → Replace.



Engine temperature sensor resistance
0.90–1.10 kΩ at 100 °C (212 °F)

- a. Connect the pocket tester ($\Omega \times 1 \text{ k}$) to the engine temperature sensor terminals as shown.



Pocket tester
90890-03112
Analog pocket tester
YU-03112-C

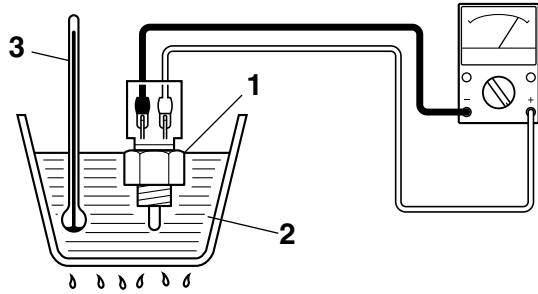

b. Immerse the engine temperature sensor “1” in a container filled with water “2”.

NOTE:

Make sure that the engine temperature sensor terminals do not get wet.

- c. Place a thermometer “3” in the water.
- d. Slowly heat the water, then let it cool down to the specified temperature.
- e. Measure the engine temperature sensor resistance.



3. Install:

- Engine temperature sensor



Engine temperature sensor
20 Nm (2.0 m·kg, 14 ft·lb)

ET1D71014

CHECKING THE FUEL SENDER (FUEL TANK)

1. Remove:
 - Fuel sender (from the fuel tank)
2. Check:
 - Fuel sender resistance
 Out of specification → Replace.



Fuel sender (fuel tank)
Sender unit resistance (full)
9–11 Ω
Sender unit resistance (empty)
213–219 Ω



a. Connect the pocket tester ($\Omega \times 100$) to the fuel sender coupler as shown.



Pocket tester
90890-03112
Analog pocket tester
YU-03112-C

- Positive tester probe → green “1”
- Negative tester probe → black “2”

b. Move the fuel sender float to maximum “3”/minimum “4” level position.

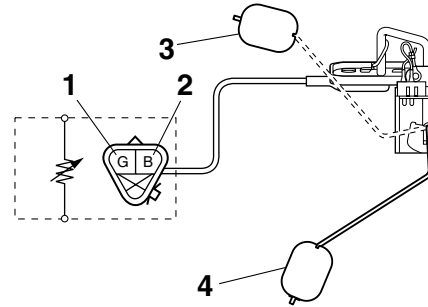

c. Measure the fuel sender resistance.



ET1D71015

CHECKING THE FUEL SENDER (FUEL PUMP)

1. Drain the fuel.
2. Disconnect:
 - Fuel pump coupler (from the fuel pump)
3. Remove:
 - Fuel pump (from the sub-fuel tank)
4. Check:
 - Fuel sender resistance
 Out of specification → Replace the fuel pump assembly.



Fuel sender resistance
0.90–2.05 kΩ



a. Connect the pocket tester ($\Omega \times 1$) to the fuel sender terminals as shown.



Pocket tester
90890-03112
Analog pocket tester
YU-03112-C

- Positive tester probe → green/white “1”
- Negative tester probe → black “2”

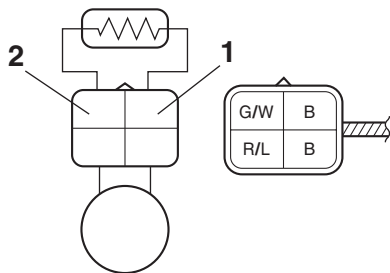

b. Measure the fuel sender resistance.



ET1D71044

CHECKING THE FUEL LEVEL WARNING LIGHT

This model is equipped with a self-diagnosis device for the fuel level detection circuit.

1. Check:

- Fuel level warning light “1”
(Turn the main switch to “ON”.)
Warning light comes on for a few seconds, then goes off → Warning light is OK.
Warning light does not come on → Replace the meter assembly.
Warning light flashes eight times, then goes off for three seconds in a repeated cycle (malfunction detected in fuel sender or thermistor) → Replace the fuel pump assembly.

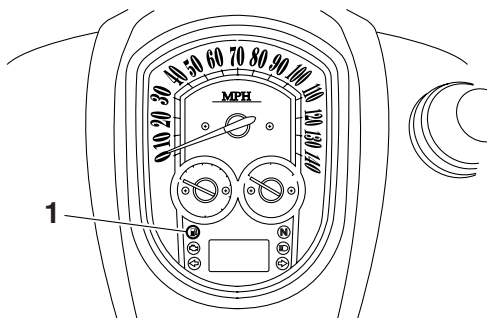

EAS28240

CHECKING THE SPEED SENSOR

1. Check:

- Speed sensor output voltage
Out of specification → Replace.

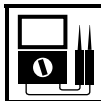

Output voltage reading cycle
0.6 V to 4.8 V to 0.6 V to 4.8 V

a. Connect the pocket tester (DC 20 V) to the speed sensor coupler as shown.



Pocket tester
90890-03112
Analog pocket tester
YU-03112-C

- Positive tester probe → white “1”
- Negative tester probe → black “2”

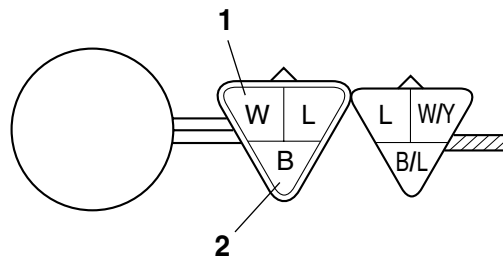

- b. Turn the main switch to “ON”.
- c. Elevate the rear wheel and slowly rotate it.
- d. Measure the voltage of white and black. With each full rotation of the rear wheel, the voltage reading should cycle from 0.6 V to 4.8 V to 0.6 V to 4.8 V.



EAS28300

CHECKING THE THROTTLE POSITION SENSOR

1. Remove:

- Throttle position sensor
(from the throttle body)

2. Check:

- Throttle position sensor maximum resistance
Out of specification → Replace the throttle position sensor.



Resistance
XV19S(C)/ XV19M(C)/
XV19CTS(C)/ XV19CTM(C):
4.0–6.0 kΩ/blue-black
XV19CS(C)/ XV19C(C):
3.1–5.7 kΩ/blue-black



a. Connect the pocket tester ($\Omega \times 1k$) to the throttle position sensor terminals as shown.



Pocket tester
90890-03112
Analog pocket tester
YU-03112-C

- Positive tester probe → blue “1”
- Negative tester probe → black “2”

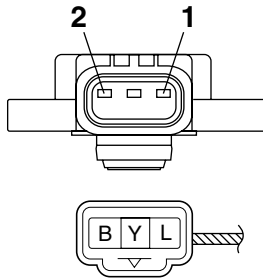

b. Measure the throttle position sensor maximum resistance.



3. Install:

- Throttle position sensor

NOTE:

When installing the throttle position sensor, adjust its angle properly. Refer to “ADJUSTING THE THROTTLE POSITION SENSOR” on page 6-16.

EAS28360

CHECKING THE FUEL PUMP

EWA13850



Gasoline is extremely flammable and under certain circumstances there can be a danger of an explosion or fire. Be extremely careful and note the following points:

- Stop the engine before refueling.
- Do not smoke, and keep away from open flames, sparks, or any other source of fire.
- If you do accidentally spill gasoline, wipe it up immediately with dry rags.
- If gasoline touches the engine when it is hot, a fire may occur. Therefore, make sure the engine is completely cool before performing the following test.

1. Disconnect:

- Fuel pump coupler (from the fuel pump)

2. Check:

- Fuel pump operation
Faulty/rough movement → Replace.



a. Fill the fuel tank.

b. Put the end of the fuel hose “1” into an open container.

c. Connect the battery (DC 12 V) to the fuel pump terminals as shown.

- Positive battery lead → red/blue “2”
- Negative battery lead → black “3”

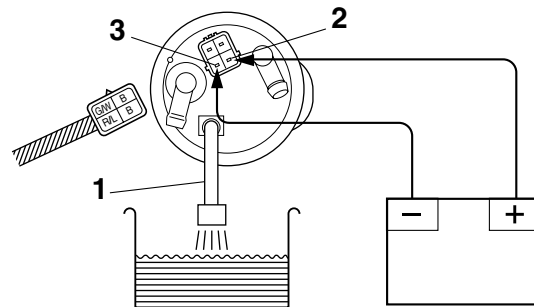

d. Check the fuel pump operation.



EAS28360

CHECKING THE EXUP SERVO MOTOR

1. Check:

- EXUP servo motor operation
Out of specification → Replace.



a. Disconnect the EXUP cables from the EXUP servo motor pulley.

b. Disconnect the EXUP servo motor coupler from the wire harness.

c. Connect the battery leads to the EXUP servo motor terminals as shown.

For counterclockwise rotation “a”

- Positive battery lead → black/green “1”
- Negative battery lead → black/red “2”

For clockwise rotation “b”

- Positive battery lead → black/red “2”
- Negative battery lead → black/green “1”

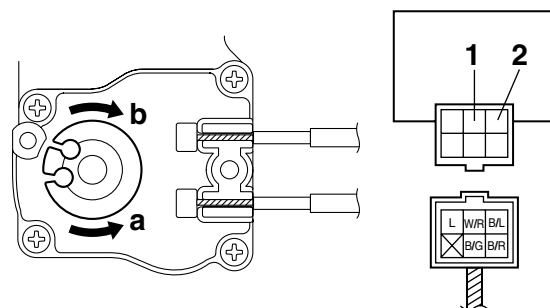

d. Check that the EXUP servo motor pulley rotates several times in directions “a” and “b”.

ECA14390

CAUTION:

To prevent damaging the EXUP servo motor, perform this test within a few seconds of connecting the battery.



EAS28410

CHECKING THE INTAKE AIR PRESSURE SENSOR

The following procedure applies to both of the intake air pressure sensors.

1. Check:

- Intake air pressure sensor output voltage
Out of specification → Replace.



Intake air pressure sensor output voltage
3.75–4.25 V

a. Connect the pocket tester (DC 20 V) to the intake air pressure sensor coupler as shown.



Pocket tester
90890-03112
Analog pocket tester
YU-03112-C

- Positive tester probe → pink/white “1” or pink/yellow
- Negative tester probe → black/blue “2”

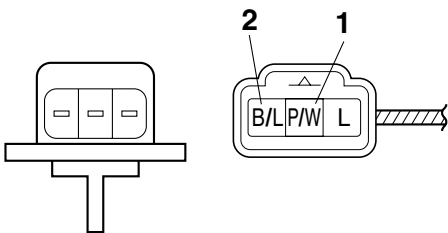

- b. Turn the main switch to “ON”.
- c. Measure the intake air pressure sensor output voltage.



ET1D71016

CHECKING THE AIR TEMPERATURE SENSOR

1. Remove:

- Air temperature sensor

EW1D71004

WARNING

- Handle the air temperature sensor with special care.
- Never subject the air temperature sensor to strong shocks. If the air temperature sensor is dropped, replace it.

2. Check:

- Air temperature sensor resistance
Out of specification → Replace.



Air temperature sensor resistance
290–390 Ω at 80 °C (176 °F)

a. Connect the pocket tester (Ω × 100) to the air temperature sensor terminals as shown.



Pocket tester
90890-03112
Analog pocket tester
YU-03112-C

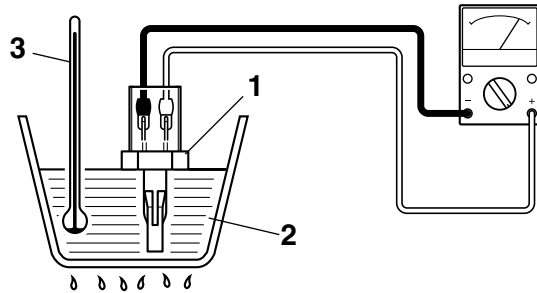

b. Immerse the air temperature sensor “1” in a container filled with water “2”.

NOTE:

Make sure that the air temperature sensor terminals do not get wet.

- c. Place a thermometer “3” in the water.
- d. Slowly heat the water, then let it cool down to the specified temperature.
- e. Measure the air temperature sensor resistance.



TROUBLESHOOTING

TROUBLESHOOTING	8-1
GENERAL INFORMATION	8-1
STARTING FAILURES.....	8-1
INCORRECT ENGINE IDLING SPEED	8-1
POOR MEDIUM AND HIGH-SPEED PERFORMANCE	8-2
FAULTY GEAR SHIFTING.....	8-2
SHIFT PEDAL DOES NOT MOVE	8-2
JUMPS OUT OF GEAR.....	8-2
FAULTY CLUTCH	8-2
OVERHEATING	8-3
POOR BRAKING PERFORMANCE.....	8-3
FAULTY FRONT FORK LEGS.....	8-3
UNSTABLE HANDLING	8-3
FAULTY LIGHTING OR SIGNALING SYSTEM.....	8-4

EAS28450

TROUBLESHOOTING

EAS28460

GENERAL INFORMATION

NOTE:

The following guide for troubleshooting does not cover all the possible causes of trouble. It should be helpful, however, as a guide to basic troubleshooting. Refer to the relative procedure in this manual for checks, adjustments, and replacement of parts.

EAS28470

STARTING FAILURES

Engine

1. Cylinder(s) and cylinder head(s)
 - Loose spark plug
 - Loose cylinder head or cylinder
 - Damaged cylinder head gasket
 - Damaged cylinder gasket
 - Worn or damaged cylinder
 - Incorrect valve clearance
 - Improperly sealed valve
 - Incorrect valve-to-valve-seat contact
 - Incorrect valve timing
 - Faulty valve spring
 - Seized valve
2. Piston(s) and piston ring(s)
 - Improperly installed piston ring
 - Damaged, worn or fatigued piston ring
 - Seized piston ring
 - Seized or damaged piston
3. Air filter
 - Improperly installed air filter
 - Clogged air filter element
4. Crankcase and crankshaft
 - Improperly assembled crankcase
 - Seized crankshaft

Fuel system

1. Fuel tank
 - Empty fuel tank
 - Clogged fuel filter
 - Clogged fuel tank overflow/breather hose
 - Clogged rollover valve
 - Clogged rollover valve hose
 - Deteriorated or contaminated fuel
2. Fuel pump
 - Faulty fuel pump
 - Faulty relay unit (fuel pump relay)
3. Throttle body(-ies)
 - Deteriorated or contaminated fuel

- Sucked-in air

Electrical system

1. Battery
 - Discharged battery
 - Faulty battery
2. Fuse(s)
 - Blown, damaged or incorrect fuse
 - Improperly installed fuse
3. Spark plug(s)
 - Incorrect spark plug gap
 - Incorrect spark plug heat range
 - Fouled spark plug
 - Worn or damaged electrode
 - Worn or damaged insulator
 - Faulty spark plug cap
4. Ignition coil(s)
 - Cracked or broken ignition coil body
 - Broken or shorted primary or secondary coils
 - Faulty spark plug lead
5. Ignition system
 - Faulty ECU
 - Faulty crankshaft position sensor
 - Broken generator rotor woodruff key
6. Switches and wiring
 - Faulty main switch
 - Faulty engine stop switch
 - Broken or shorted wiring
 - Faulty neutral switch
 - Faulty start switch
 - Faulty sidestand switch
 - Faulty clutch switch
 - Improperly grounded circuit
 - Loose connections
7. Starting system
 - Faulty starter motor
 - Faulty starter relay
 - Faulty relay unit (starting circuit cut-off relay)
 - Faulty starter clutch

EAS28490

INCORRECT ENGINE IDLING SPEED

Engine

1. Cylinder(s) and cylinder head(s)
 - Incorrect valve clearance
 - Damaged valve train components
2. Air filter
 - Clogged air filter element

Fuel system

1. Throttle body(-ies)
 - Damaged or loose throttle body joint
 - Improperly synchronized throttle bodies

- Improper throttle cable free play
- Flooded throttle body

Electrical system

1. Battery
 - Discharged battery
 - Faulty battery
2. Spark plug(s)
 - Incorrect spark plug gap
 - Incorrect spark plug heat range
 - Fouled spark plug
 - Worn or damaged electrode
 - Worn or damaged insulator
 - Faulty spark plug cap
3. Ignition coil(s)
 - Broken or shorted primary or secondary coils
 - Faulty spark plug lead
 - Cracked or broken ignition coil
4. Ignition system
 - Faulty ECU
 - Faulty crankshaft position sensor
 - Broken generator rotor woodruff key

EAS28510

POOR MEDIUM AND HIGH-SPEED PERFORMANCE

Refer to "STARTING FAILURES" on page 8-1.

Engine

1. Air filter
 - Clogged air filter element

Fuel system

1. Fuel pump
 - Faulty fuel pump

EAS28530

FAULTY GEAR SHIFTING

Shifting is difficult

Refer to "Clutch drags".

EAS28540

SHIFT PEDAL DOES NOT MOVE

Shift shaft

- Improperly adjusted shift rod
- Bent shift shaft

Shift drum and shift forks

- Foreign object in a shift drum groove
- Seized shift fork
- Bent shift fork guide bar

Transmission

- Seized transmission gear

- Foreign object between transmission gears
- Improperly assembled transmission

EAS28550

JUMPS OUT OF GEAR

Shift shaft

- Incorrect shift pedal position
- Improperly returned stopper lever

Shift forks

- Worn shift fork

Shift drum

- Incorrect axial play
- Worn shift drum groove

Transmission

- Worn gear dog

EAS28570

FAULTY CLUTCH

Clutch slips

1. Clutch
 - Improperly assembled clutch
 - Improperly assembled clutch master cylinder
 - Improperly assembled clutch release cylinder
 - Incorrect clutch fluid level
 - Damaged clutch hose
 - Loose or fatigued clutch spring
 - Loose union bolt
 - Worn friction plate
 - Worn clutch plate
 - Damaged clutch release cylinder
2. Engine oil
 - Incorrect oil level
 - Incorrect oil viscosity (low)
 - Deteriorated oil

Clutch drags

1. Clutch
 - Air in hydraulic clutch system
 - Unevenly tensioned clutch springs
 - Warped pressure plate
 - Bent clutch plate
 - Swollen friction plate
 - Bent clutch push rod
 - Damaged clutch boss
 - Burnt primary driven gear bushing
 - Damaged clutch release cylinder
 - Match marks not aligned
2. Engine oil
 - Incorrect oil level
 - Incorrect oil viscosity (high)

- Deteriorated oil

EAS28590

OVERHEATING

Engine

1. Cylinder head(s) and piston(s)
 - Heavy carbon buildup
2. Engine oil
 - Incorrect oil level
 - Incorrect oil viscosity
 - Inferior oil quality

Fuel system

1. Throttle body(-ies)
 - Faulty throttle body(-ies)
 - Damaged or loose throttle body joint
2. Air filter
 - Clogged air filter element

Chassis

1. Brake(s)
 - Dragging brake

Electrical system

1. Spark plug(s)
 - Incorrect spark plug gap
 - Incorrect spark plug heat range
2. Ignition system
 - Faulty ECU

EAS28620

POOR BRAKING PERFORMANCE

- Worn brake pad
- Worn brake disc
- Air in hydraulic brake system
- Leaking brake fluid
- Faulty brake caliper kit
- Faulty brake caliper seal
- Loose union bolt
- Damaged brake hose
- Oil or grease on the brake disc
- Oil or grease on the brake pad
- Incorrect brake fluid level

EAS28660

FAULTY FRONT FORK LEGS

Leaking oil

- Bent, damaged or rusty inner tube
- Cracked or damaged outer tube
- Improperly installed oil seal
- Damaged oil seal lip
- Incorrect oil level (high)
- Loose damper rod assembly bolt

- Damaged damper rod assembly bolt copper washer
- Cracked or damaged cap bolt O-ring

Malfunction

- Bent or damaged inner tube
- Bent or damaged outer tube
- Damaged fork spring
- Worn or damaged outer tube bushing
- Bent or damaged damper rod
- Incorrect oil viscosity
- Incorrect oil level

EAS28670

UNSTABLE HANDLING

1. Handlebar
 - Bent or improperly installed handlebar
2. Steering head components
 - Improperly installed upper bracket
 - Improperly installed lower bracket (improperly tightened ring nut)
 - Bent steering stem
 - Damaged ball bearing or bearing race
3. Front fork leg(s)
 - Uneven oil levels (both front fork legs)
 - Unevenly tensioned fork spring (both front fork legs)
 - Broken fork spring
 - Bent or damaged inner tube
 - Bent or damaged outer tube
4. Swingarm
 - Worn bearing or bushing
 - Bent or damaged swingarm
5. Rear shock absorber assembly
 - Faulty rear shock absorber spring
 - Leaking oil or gas
6. Tire(s)
 - Uneven tire pressures (front and rear)
 - Incorrect tire pressure
 - Uneven tire wear
7. Wheel(s)
 - Incorrect wheel balance
 - Deformed cast wheel
 - Damaged wheel bearing
 - Bent or loose wheel axle
 - Excessive wheel runout
8. Frame
 - Bent frame
 - Damaged steering head pipe
 - Improperly installed bearing race

EAS28710

FAULTY LIGHTING OR SIGNALING SYSTEM

Headlight does not come on

- Wrong headlight bulb
- Too many electrical accessories
- Hard charging
- Incorrect connection
- Improperly grounded circuit
- Poor contacts (main switch)
- Burnt-out headlight bulb

Headlight bulb burnt out

- Wrong headlight bulb
- Faulty battery
- Faulty rectifier/regulator
- Improperly grounded circuit
- Faulty main switch
- Headlight bulb life expired

Tail/brake light does not come on

- Wrong tail/brake light LED
- Too many electrical accessories
- Incorrect connection
- Burnt-out tail/brake light LED

Tail/brake light LED burnt out

- Wrong tail/brake light LED
- Faulty battery
- Incorrectly adjusted rear brake light switch
- Tail/brake light LED life expired

Turn signal does not come on

- Faulty turn signal switch
- Faulty turn signal relay
- Burnt-out turn signal bulb
- Incorrect connection
- Damaged or faulty wire harness
- Improperly grounded circuit
- Faulty battery
- Blown, damaged or incorrect fuse

Turn signal flashes slowly

- Faulty turn signal relay
- Faulty main switch
- Faulty turn signal switch
- Incorrect turn signal bulb

Turn signal remains lit

- Faulty turn signal relay
- Burnt-out turn signal bulb

Turn signal flashes quickly

- Incorrect turn signal bulb

- Faulty turn signal relay
- Burnt-out turn signal bulb

Horn does not sound

- Improperly adjusted horn
- Damaged or faulty horn
- Faulty main switch
- Faulty horn switch
- Faulty battery
- Blown, damaged or incorrect fuse
- Faulty wire harness

WIRING DIAGRAM**XV19SX(C)/XV19MX(C)/XV19CT
SX(C)/XV19CTMX(C) 2008**

1. AC magneto
2. Rectifier/regulator
3. Main switch
4. Main fuse
5. Backup fuse (odometer and clock)
6. Battery
7. Fuel injection system fuse
8. Starter relay
9. Starter motor
10. Diode 1
11. Relay unit
12. Starting circuit cut-off relay
13. Fuel pump relay
14. Neutral switch
15. Diode 2
16. Sidestand switch
17. Fuel pump
18. Fuel sender (fuel pump)
19. Crankshaft position sensor
20. Throttle position sensor
21. Cylinder-#1 intake air pressure sensor
22. Cylinder-#2 intake air pressure sensor
23. Lean angle sensor
24. Speed sensor
25. Air temperature sensor
26. Engine temperature sensor
27. ECU (electronic control unit)
28. Cylinder-#1 left ignition coil
29. Cylinder-#1 right ignition coil
30. Cylinder-#2 left ignition coil
31. Cylinder-#2 right ignition coil
32. Spark plug
33. ISC (idle speed control) unit
34. EXUP servo motor
35. Injector #2
36. Injector #1
37. O₂ sensor
38. Meter assembly
39. Neutral indicator light
40. Multi-function meter
41. Reset switch
42. Engine trouble warning light
43. Fuel level warning light
44. Meter light
45. Left turn signal indicator light
46. Right turn signal indicator light
47. High beam indicator light
48. Fuel sender (fuel tank)
49. Horn 1
50. Horn 2
51. Turn signal relay
52. Headlight relay
53. Left handlebar switch

54. Clutch switch
55. Dimmer switch
56. Turn signal switch
57. Horn switch
58. Select switch
59. Front right turn signal/position light
60. Front left turn signal/position light
61. Headlight assembly
62. Headlight (high beam)
63. Headlight (low beam)
64. Right handlebar switch
65. Front brake light switch
66. Engine stop switch
67. Start switch
68. Accessory light switch
69. Accessory light (OPTION)
70. Tail/brake light assembly
71. Tail/brake light
72. License plate light
73. Rear left turn signal light
74. Rear right turn signal light
75. Rear brake light switch
76. Auxiliary DC coupler
77. Auxiliary DC connector fuse
78. Ignition fuse
79. Headlight fuse
80. Signaling system fuse
81. Taillight fuse
82. ECU fuse

COLOR CODE

B	Black
Br	Brown
Ch	Chocolate
Dg	Dark green
G	Green
Gy	Gray
L	Blue
O	Orange
P	Pink
R	Red
Sb	Sky blue
W	White
Y	Yellow
B/Br	Black/Brown
B/G	Black/Green
B/L	Black/Blue
B/R	Black/Red
B/Y	Black/Yellow
Br/L	Brown/Blue
Br/W	Brown/White
G/L	Green/Blue
G/R	Green/Red
G/W	Green/White
G/Y	Green/Yellow
Gy/G	Gray/Green
Gy/R	Gray/Red
Gy/W	Gray/White
L/B	Blue/Black
L/G	Blue/Green
L/R	Blue/Red
L/W	Blue/White
L/Y	Blue/Yellow
P/L	Pink/Blue
P/W	Pink/White
P/Y	Pink/Yellow
R/B	Red/Black
R/G	Red/Green
R/L	Red/Blue
R/W	Red/White
R/Y	Red/Yellow
Sb/W	Sky blue/White
W/B	White/Black
W/G	White/Green
W/R	White/Red
W/Y	White/Yellow
Y/B	Yellow/Black
Y/G	Yellow/Green
Y/L	Yellow/Blue
Y/R	Yellow/Red

WIRING DIAGRAM**XV19CSX(C)/XV19CX(C) 2008**

1. AC magneto
2. Rectifier/regulator
3. Main switch
4. Main fuse
5. Battery
6. Fuel injection system fuse
7. Starter relay
8. Starter motor
9. Relay unit
10. Starting circuit cut-off relay
11. Fuel pump relay
12. Neutral switch
13. Sidestand switch
14. Fuel pump
15. Fuel sender (fuel pump)
16. Engine temperature sensor
17. Crankshaft position sensor
18. Throttle position sensor
19. Cylinder-#1 intake air pressure sensor
20. Cylinder-#2 intake air pressure sensor
21. Speed sensor
22. Lean angle sensor
23. Air temperature sensor
24. ECU (electronic control unit)
25. Cylinder-#1 left ignition coil
26. Cylinder-#1 right ignition coil
27. Cylinder-#2 left ignition coil
28. Cylinder-#2 right ignition coil
29. Spark plug
30. Injector #2
31. Injector #1
32. O₂ sensor
33. EXUP servo motor
34. ISC (idle speed control) unit
35. Meter assembly
36. Neutral indicator light
37. Multi-function meter
38. Engine trouble warning light
39. Fuel level warning light
40. Reset switch
41. Meter light
42. High beam indicator light
43. Left turn signal indicator light
44. Right turn signal indicator light
45. Fuel sender (fuel tank)
46. Horn 1
47. Horn 2
48. Turn signal relay
49. Headlight relay
50. Left handlebar switch
51. Clutch switch
52. Dimmer switch
53. Turn signal switch
54. Horn switch
55. Select switch

56. Front right turn signal/position light
57. Front left turn signal/position light
58. Headlight
59. Accessory light (OPTION)
60. Right handlebar switch
61. Front brake light switch
62. Engine stop switch
63. Start switch
64. Accessory light switch
65. Rear right turn signal light
66. Rear left turn signal light
67. License plate light
68. Tail/brake light
69. Rear brake light switch
70. Auxiliary DC coupler
71. Auxiliary DC connector fuse
72. Ignition fuse
73. Signaling system fuse
74. Taillight fuse
75. Headlight fuse
76. Backup fuse (odometer and clock)

COLOR CODE

B	Black
Br	Brown
Ch	Chocolate
Dg	Dark green
G	Green
Gy	Gray
L	Blue
O	Orange
P	Pink
R	Red
Sb	Sky blue
W	White
Y	Yellow
B/Br	Black/Brown
B/G	Black/Green
B/L	Black/Blue
B/R	Black/Red
B/Y	Black/Yellow
Br/L	Brown/Blue
Br/W	Brown/White
G/L	Green/Blue
G/R	Green/Red
G/W	Green/White
G/Y	Green/Yellow
Gy/G	Gray/Green
Gy/R	Gray/Red
Gy/W	Gray/White
L/B	Blue/Black
L/G	Blue/Green
L/R	Blue/Red
L/W	Blue/White
L/Y	Blue/Yellow
P/L	Pink/Blue
P/W	Pink/White
P/Y	Pink/Yellow
R/B	Red/Black
R/G	Red/Green
R/L	Red/Blue
R/W	Red/White
R/Y	Red/Yellow
Sb/W	Sky blue/White
W/B	White/Black
W/G	White/Green
W/R	White/Red
W/Y	White/Yellow
Y/B	Yellow/Black
Y/G	Yellow/Green
Y/L	Yellow/Blue
Y/R	Yellow/Red





YAMAHA MOTOR CO., LTD.
2500 SHINGAI IWATA SHIZUOKA JAPAN

XV19CSX(C)/XV19CX(C) 2008 WIRING DIAGRAM

